



Technical  
Documentation

# KFM-P 2040 INCLINE PLASTIC MODULAR BELT CONVEYOR

Each serial number is unique to that specific unit and provides mk North America with complete order details.

---

|      |   |    |
|------|---|----|
| 1    | General Information   | 3  |
| 2    | Decoding Your Serial Number                                 | 4  |
| 3    | Conveyor Description  | 5  |
| 4    | Warranty Information  | 7  |
| 5    | Safety Requirements   | 8  |
| 6    | Wear Items & Maintenance For Specific Drive & Tail Options  | 9  |
| 7    | Conveyor Belt Maintenance - Tensioning & Tracking           | 14 |
| 8    | Conveyor Belt Maintenance - Belt Replacement                | 16 |
| 9    | Conveyor Maintenance - Tensioning & Greasing Of Drive Chain | 18 |
| 10.2 | Contacting mk North America, Inc.                           | 21 |

## 1 GENERAL INFORMATION

### 1.1 Foreword

Congratulations on purchasing a turntable from mk North America, Inc., a leading manufacturer of quality low profile conveyors and turntables. Our more than 30 years experience in material handling allows us to offer robust solutions with long life and reliable operation. We strive to make the best products in the industry even better and we are committed to making sure our customers get top notch support before, during, and after each and every sale.

### 1.2 The importance of reading your manual

Inside this manual you will find the instructions on how to set up and maintain your mk turntable properly, as well as maximize its performance. Please take the time to read this manual and familiarize yourself with these set up and maintenance instructions. These instructions will help assure a long product life that requires a minimum amount of service and keeps your turntable working at its maximum capacity.

### 1.3 If you need assistance

If you need assistance there are a variety of ways to get it. You can contact our customer service team Monday through Friday, 8am-5pm (Eastern Time) at (860) 769-5500. You can also visit our website for additional information and technical documentation at [www.mknorthamerica.com](http://www.mknorthamerica.com). In addition, your local representative can provide support in many instances.

### 1.4 When your shipment arrives

- 1) Check your shipment
  - a) If you have not already done so, visually inspect the shipping crate/container for any damage caused during shipment.
  - b) Carefully unpack the crate/container making sure to inspect the components for damage that may have occurred inside the packaging materials.
  - c) If you find any damage, please contact the carrier and mk North America, Inc.
  - d) Lastly, check the contents against the packing slip provided by mk for any discrepancies. If you should find any, please contact mk North America, Inc.
- 2) Locate your ordered items
  - a) Each mk turntable will ship in its own custom built container, carefully packaged in the most economical way.
  - b) Review the packing slip against your Purchase Order.

## 2 SERIAL NUMBER LABEL

- The turntable's serial number is located on the frame at the drive end of the turntable.

|   |  |  |       |                        |
|---|--|--|-------|------------------------|
|  | Type:                                    |  | Date: |                        |
|   | Serial #:                                |  | CO #: |                        |
|   | Drawing #:                               |  |       |                        |
|   | www.mknorthamerica.com    (860) 769-5500 |  |       |                        |
|   |  |  |       | Scan for Documentation |

### Type:

This description refers to the type of unit that is associated with the particular serial number. The type should NOT be substituted for the serial number when inquiring.

### Serial #:

This number is unique to this item. With this number we can access all of the original order details.

### Drawing #:

This number, if applicable, refers to the specific drawing that was created for this unit.

### Date:

This is the date that the unit was scheduled to ship.

### CO#:

This is the customer order number in which this unit was built. This is an mk North America, Inc. internal number. This number is also referenced on any related invoices, etc.

### Scan for Documentation:

Scanning this QR code will bring you to a webpage specific for the turntable on this order. From here you can access drawings and spare parts.

## 3 CONVEYOR DESCRIPTION

### 3.1 Explaining the conveyor **TYPE**.

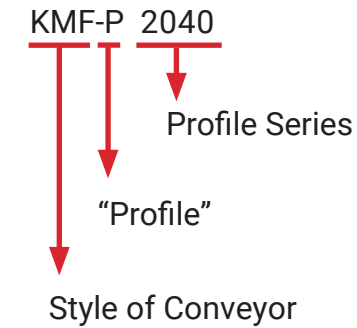

### Style of Conveyor

DGF (Doppel-Gurt Foerderer) Dual-Belt Conveyor

GUF (Gurt Foerderer) Belt Conveyor

KFG (Knickfoerderer Gurt) Bent "Gooseneck" Belt Conveyor

KFM (Knickförder Modular) Bent "Gooseneck" Plastic Modular Belt Conveyor

KGF (Kurvengurt Foerderer) Curve Belt Conveyor

KMF (Kurvengängiges Modulband) Curved Modular Belt Conveyor

KTF (Kettengurt Foerderer) Chain Conveyor

MBF (Modulband Foerderer) Modular Belt Conveyor

RBM (Rollenbahn Motor) Motorized Roller Conveyor

RBS (Rollerbahn Schwerkraft) Idler Roller Conveyor

RBT (Rollenbahn Tangentialkette) Drive Roller Conveyor

SBF (Scharnierband Foerderer) Hinged Belt Conveyor

SPU (Staufaehiges Pallettenumlaufsystem) Continuous Motion Pallet Conveyor

SRF (Staurollen Foerderer) Accumulating Roller Conveyor

TKU (Taktkettenförderer) Timing Chain Conveyor

ZRF (Zahnriemen Förderer) Timing Belt Conveyor

### 3 CONVEYOR DESCRIPTION

(CONT.)

#### 3.2 Conveyor Components

The KFM-P 2040 has many typical conveyor components. Below is a description of the basic parts and options for the KFM-P 2040 conveyor. The items you receive will vary based on your actual purchase order. Items may appear different on your model based on your particular order requirements. Consult your approval drawing for specifics items included in your order.

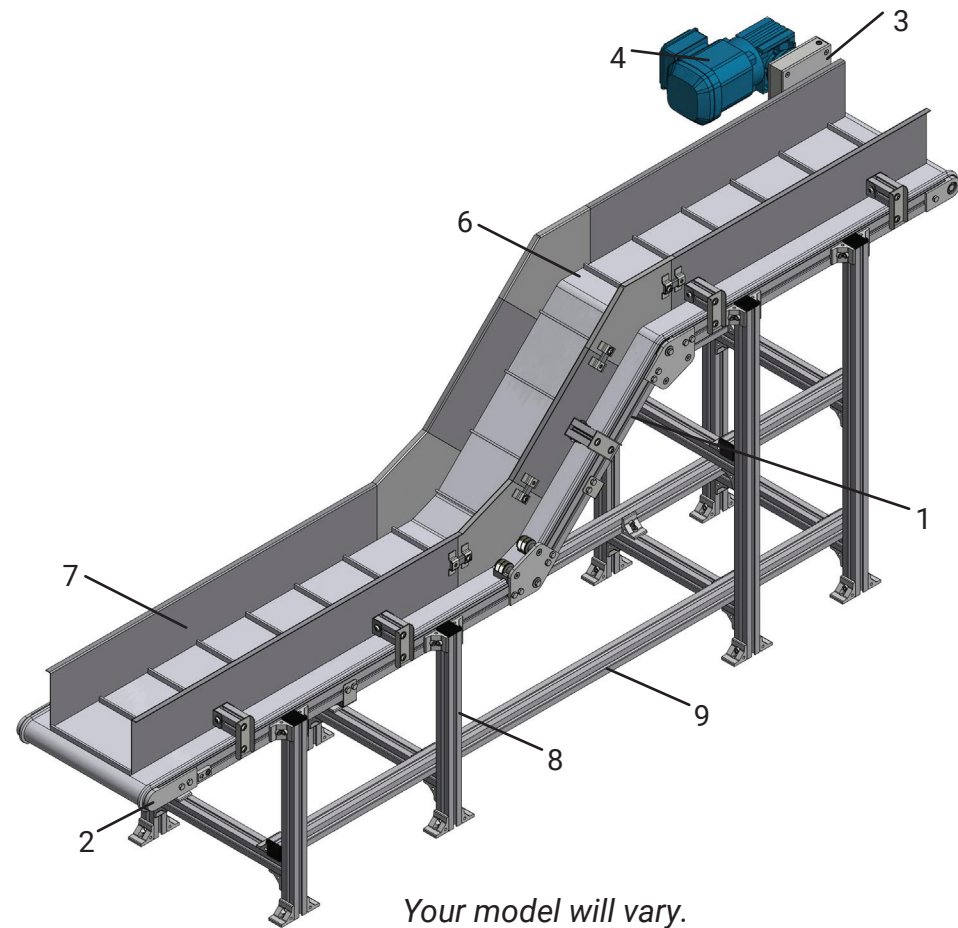

#### Typical Components

- 1) Conveyor Frame
- 2) Idler End
- 3) Gearmotor Mount/Drive Assembly
- 4) Gearmotor
- 5) Speed Control (Not Shown)
- 6) Belt
- 7) Side Rails
- 8) Support Stand
- 9) Stand Stringer

### 4 WARRANTY INFORMATION

#### Warranty

mk North America, Inc. (MKNA) offers a COMPLETE ONE YEAR WARRANTY from the date of delivery, to the original purchaser of the MKNA equipment (CUSTOMER), to be free from defects in material and workmanship; under normal use and with proper installation, maintenance and cleaning.

Additionally MKNA offers a LIMITED 10 YEAR WARRANTY on all equipment that MKNA is the original manufacturer of, to be free from defect and workmanship.<sup>1</sup>

This warranty is extended by MKNA only to CUSTOMER, and is non-transferable. All warranty requests shall be made by CUSTOMER.

MKNA will replace or repair, at our factory or any other location we designate<sup>2</sup>, any defective part within the warranty period and without charge. It is at MKNA's sole discretion whether to repair or replace. CUSTOMER will provide MKNA with a prompt written notice of the defect, including the serial number of the unit (when applicable) and the date of delivery.

At MKNA's request CUSTOMER will return all defective parts for evaluation at MKNA. MKNA will provide CUSTOMER with a return goods authorization number (RGA#). No parts will be returned without a RGA#. The RGA# must clearly be marked on all labels, packages and packing slips.

CUSTOMER shall pay all costs for packaging, shipping, duties and/or any other related costs in the sending or receiving of parts. CUSTOMER is responsible for all labor associated with sending or receiving of parts.

MKNA PROVIDES NO WARRANTY OF MERCHANTABILITY OR FITNESS FOR A PARTICULAR PURPOSE; UNLESS IT IS AGREED TO BY MKNA AND CUSTOMER IN WRITING PRIOR TO PLACEMENT OF ORDER. Such agreement requires approval of MKNA Management.

UNDER NO CIRCUMSTANCES SHALL MKNA BE HELD LIABLE FOR DAMAGES OR LIABILITY FOR LOSS OF PRODUCTION, PRODUCT, EQUIPMENT OR PROFITS OR LIABILITY FOR DIRECT, INCIDENTAL, INDIRECT, SPECIAL OR CONSEQUENTIAL DAMAGES OR ANY DAMAGES TO PERSONS OR PROPERTY, WHATSOEVER. CUSTOMER agrees that it is their sole remedy for liability of any kind, including negligence with respect to the equipment and services furnished by MKNA shall be limited to the remedies provided herein. This warranty shall not apply to any failure of the unit or its components caused by lack of maintenance and/or improper maintenance, incorrect adjustments, misuse or unreasonable use or exposure to chemicals and/or environments which the unit is not designed for. Unauthorized modification of the unit or the use of non-MKNA replacement parts and building components voids this warranty.

<sup>1</sup> The limited 10 year warranty does not apply to equipment and components manufactured by others. Such equipment and components are subject to any limitation contained in the original manufacturer's warranty and include, but are not limited to: bearings, belts, casters, controllers, motors and pneumatic devices.

<sup>2</sup> No work will be performed by MKNA or an MKNA factory authorized service representative at the site of installation unless in MKNA's opinion it is impractical for Customer to remove and return the defective part to MKNA's factory.

EXCEPT AS EXPRESSLY STATED HEREIN, THERE ARE NO WARRANTIES, EXPRESSED OR IMPLIED, BY OPERATION OF LAW OR OTHERWISE, OF THE EQUIPMENT OR SERVICES FURNISHED BY MKNA OR FACTORY AUTHORIZED SERVICE REPRESENTATIVE. THERE ARE NO WARRANTIES WHICH EXTEND BEYOND THE DESCRIPTION ON THE FACE HEREOF.

mk North America, Inc. reserves the right to change, modify or discontinue products and/or specifications with or without notice.

All of mk North America, Inc. products are covered by this warranty.

## 5 SAFETY REQUIREMENTS

### 5.1 Warnings - Safety Guidelines

**READ AND UNDERSTAND ALL OF THESE WARNINGS PRIOR TO OPERATING EQUIPMENT.**

|   |  |   |   |
|---|--|---|---|
| <p><b>CAUTION</b></p>  <p>Read this manual before operating conveyors.</p>   | <p><b>CAUTION</b></p>  <p>Never operate or service equipment under the influence of drugs and/or alcohol.</p>   | <p><b>CAUTION</b></p>  <p>Lock out power before servicing the conveyor.</p>   | <p><b>WARNING</b></p>  <p>Do NOT operate conveyors without guards in place.<br/>Severe injury can occur.</p> |
| <p><b>IMPORTANT</b></p>  <p>Conveyors must be installed so that they are square and level – across the belt. Failure to install conveyors correctly may cause premature equipment failure and/or product damage.</p> | <p><b>WARNING</b></p>  <p>Do not operate conveyors in an explosive environment.</p>   | <p><b>DANGER</b></p>  <p>Moving equipment can cause severe injury or death.<br/>Do NOT touch moving parts. Lock out power before servicing.</p> | <p><b>WARNING</b></p>  <p>Gearmotors will be hot. Do NOT touch.<br/>Severe injury can occur.</p>           |
| <p><b>DANGER</b></p>  <p>Climbing, sitting, walking or riding on the conveyor at any time could result in severe injury or death.<br/><b>KEEP OFF!</b></p>   | <p><b>DANGER</b></p>  <p>Always support conveyor sections prior to loosening stands or supports. Loosening stands or supports can cause the conveyor to fall creating a crush hazard.</p> | <p><b>NOTICE</b></p>  <p>All work should be done by qualified professionals. This includes electricians for all wiring.</p>                     |   |

## 6 WEAR ITEMS & MAINTENANCE FOR SPECIFIC DRIVE OPTIONS

|     |  |    |
|-----|--|----|
| 6.1 | Important Notes About Wear Items & Maintenance | 9  |
| 6.2 | KFM-P 2040 AC                                  | 10 |
| 6.4 | KFM-P 2040 AS                                  | 12 |

### 6.1 Important Notes About Wear Items & Maintenance

The following information regarding life of the wear items and service or adjustment intervals of the functional elements are only GUIDELINES. Conveyors are application-specific products whose life expectancy can vary depending on their relative loads and speeds, and which can be significantly influenced by environmental factors.

- All moving components and screw connections should be checked every 6 months.
- All safety-relevant components should be part of a regularly scheduled weekly inspection
- The proper function of these components must be confirmed at all times.
- Do NOT operate conveyors if safety-relevant components are damaged or missing.
- All parts which contact the product should be cleaned weekly (example: belt).
- Belts require little special care. They are easily cleaned using lukewarm soapy water.
- Remove heavy grease coatings with ethyl alcohol.
- Blow off debris from belts with structured surfaces using compressed air.

6 WEAR ITEMS & MAINTENANCE FOR SPECIFIC DRIVE OPTIONS (CONT.)

6.2 KFM-P 2040 AC

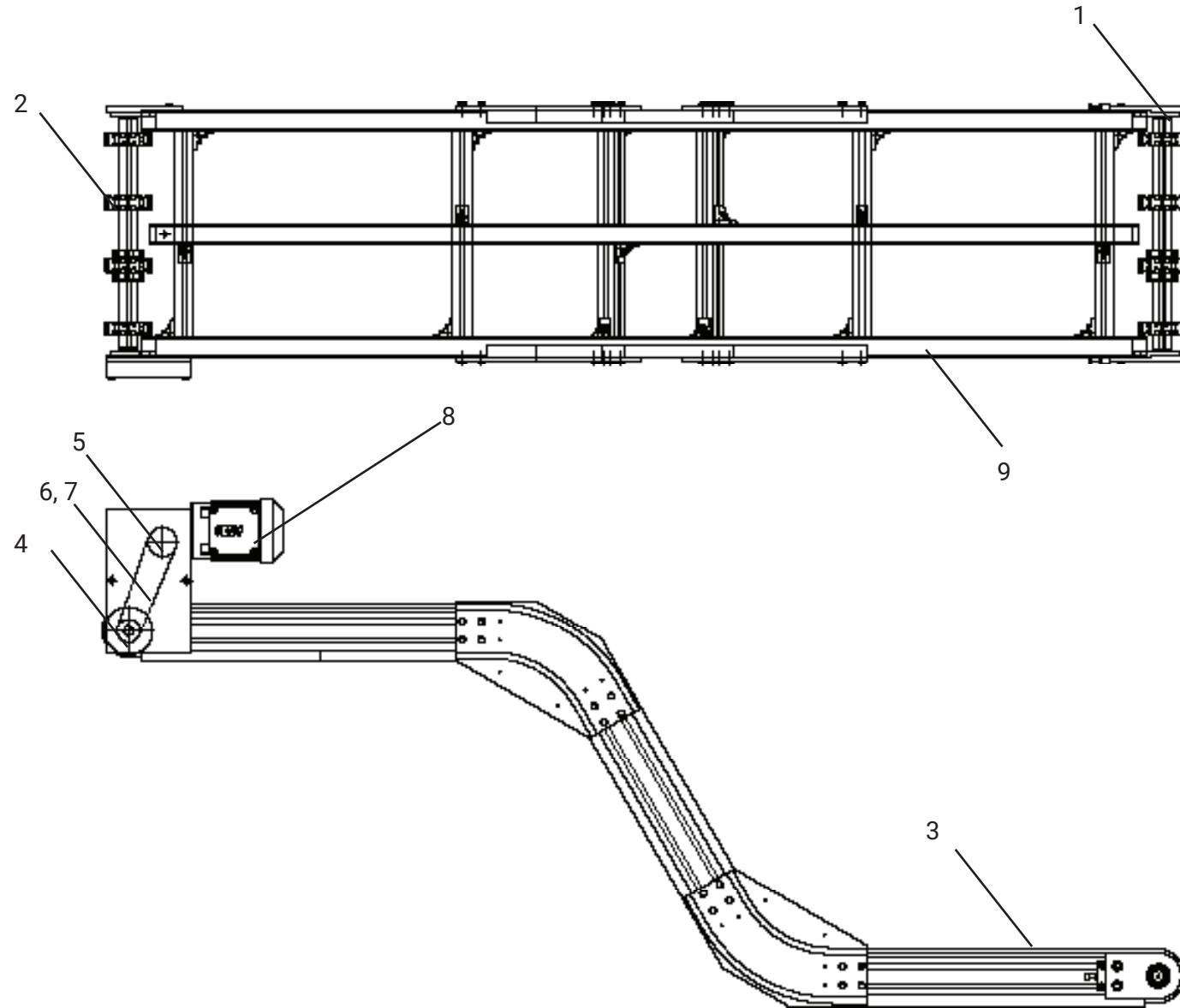

NOTE: Not all items shown in all views for clarity.

(Cont.)

6 WEAR ITEMS & MAINTENANCE FOR SPECIFIC DRIVE OPTIONS (CONT.)

6.2 KFM-P 2040 AC (Cont.)

Maintenance Work for KFM-P 2040 AC

| Position | Description             | Action*    | Interval in Hours (Months)                             | Lubricant   |
|----------|-------------------------|------------|--|-------------|
| 1        | Roller Bearing          | I          | 1,000 Hours (Max. 6 Months)                            |             |
| 2        | Drive/Idler Sprocket    | I, C       | 500 Hours (Max. 3 Months)                              |             |
| 3        | Belt                    | I, C       | 500 Hours (Max. 3 Months)                              |             |
| 4, 5     | Sprocket                | I, C       | 1,000 Hours (Max. 6 Months)                            | SAE20-SAE50 |
| 6, 7     | Chain & Connecting Link | I, C, L, T | 500 Hours (Max. 3 Months)                              | SAE20-SAE50 |
|          |                         | R          | If max. stretch is 3% of greater                       |             |
| 8        | Gearmotor               | I          | Service & Maintenance per manufacturer's documentation |             |
| 9        | Wear Strip              | I          | 1,000 Hours (Max. 6 Months)                            |             |
|          |                         | R          | Replace if thickness is less than 3 mm                 |             |

\* LEGEND: Inspect, Replace, Tension, Clean, Lubricate (grease).

Wear Items for KFM-P 2040 AC

| Position | Description                  | Part Number                   |
|----------|------------------------------|-------------------------------|
| 1        | Roller Bearing 2205-2RS      | K10101316                     |
| 2        | Drive/Idler Sprocket         | Inquire with mk North America |
| 3        | Belt                         | Inquire with mk North America |
| 4        | Sprocket at Drive Roll       | Inquire with mk North America |
| 5        | Sprocket at Gearmotor        | Inquire with mk North America |
| 6        | Roller Chain                 | Inquire with mk North America |
| 7        | Roller Chain Connecting Link | Inquire with mk North America |
| 8        | Gearmotor                    | Inquire with mk North America |
| 9        | Wear Strip                   | Inquire with mk North America |

NOTE: For adjusting the chain tensioning, please see the related section for details. When cleaning the chain, avoid any harsh chemicals or detergents.

6 WEAR ITEMS & MAINTENANCE FOR SPECIFIC DRIVE OPTIONS (CONT.)

6.4 KFM-P 2040 AS

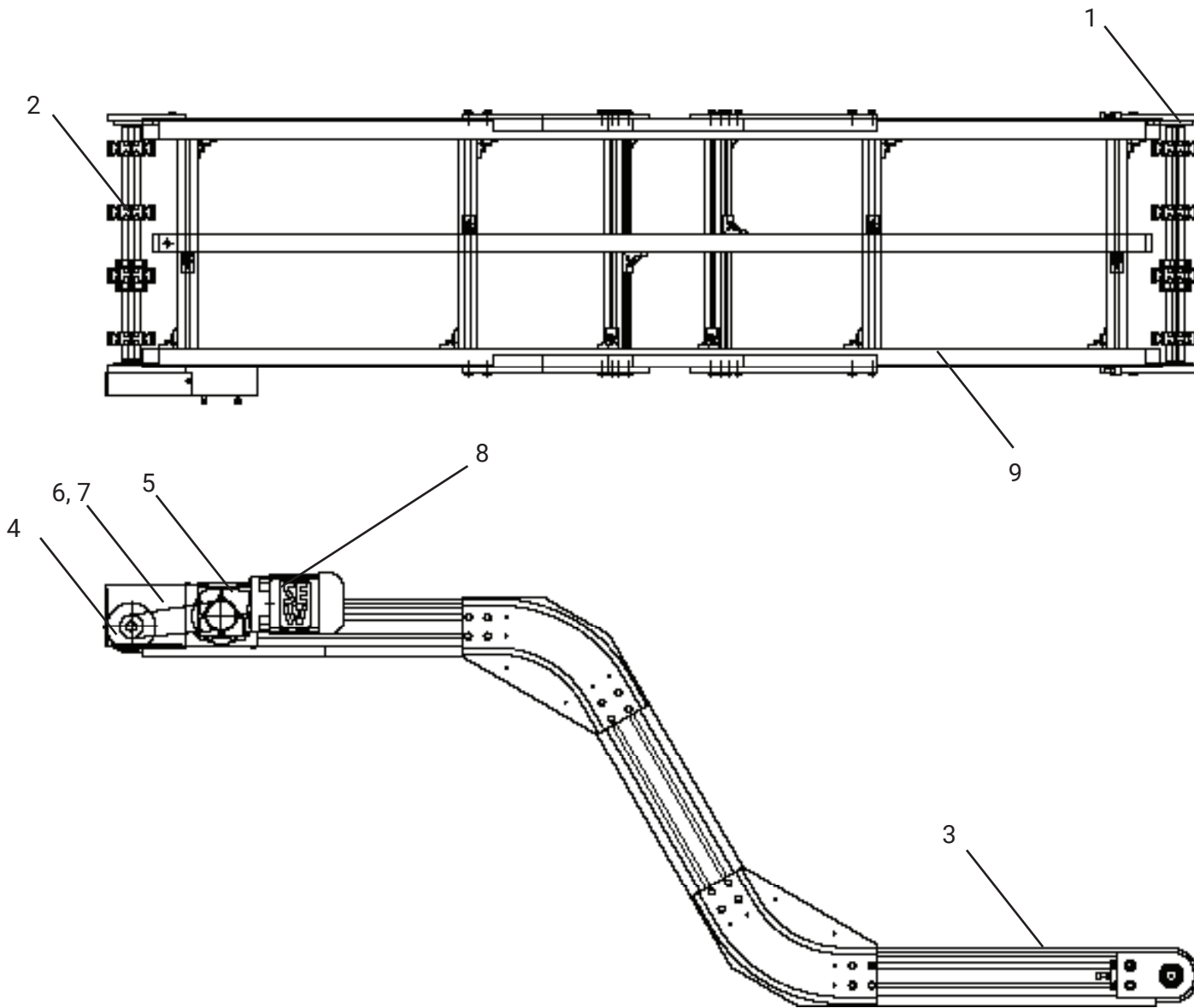

NOTE: Not all items shown in all views for clarity.

(Cont.)

6 WEAR ITEMS & MAINTENANCE FOR SPECIFIC DRIVE OPTIONS (CONT.)

6.4 KFM-P 2040 AS (Cont.)

Maintenance Work for KFM-P 2040 AS

| Position | Description             | Action*    | Interval in Hours (Months)                             | Lubricant   |
|----------|-------------------------|------------|--|-------------|
| 1        | Roller Bearing          | I          | 1,000 Hours (Max. 6 Months)                            |             |
| 2        | Drive/Idler Sprocket    | I, C       | 500 Hours (Max. 3 Months)                              |             |
| 3        | Belt                    | I, C       | 500 Hours (Max. 3 Months)                              |             |
| 4, 5     | Sprocket                | I, C       | 1,000 Hours (Max. 6 Months)                            | SAE20-SAE50 |
| 6, 7     | Chain & Connecting Link | I, C, L, T | 500 Hours (Max. 3 Months)                              | SAE20-SAE50 |
|          |                         | R          | If max. stretch is 3% of greater                       |             |
| 8        | Gearmotor               | I          | Service & Maintenance per manufacturer's documentation |             |
| 9        | Wear Strip              | I          | 1,000 Hours (Max. 6 Months)                            |             |
|          |                         | R          | Replace if thickness is less than 3 mm                 |             |

\* LEGEND: *Inspect, Replace, Tension, Clean, Lubricate (grease).*

Wear Items for KFM-P 2040 AS

| Position | Description                  | Part Number                   |
|----------|------------------------------|-------------------------------|
| 1        | Roller Bearing 2205-2RS      | K10101316                     |
| 2        | Drive/Idler Sprocket         | Inquire with mk North America |
| 3        | Belt                         | Inquire with mk North America |
| 4        | Sprocket at Drive Roll       | Inquire with mk North America |
| 5        | Sprocket at Gearmotor        | Inquire with mk North America |
| 6        | Roller Chain                 | Inquire with mk North America |
| 7        | Roller Chain Connecting Link | Inquire with mk North America |
| 8        | Gearmotor                    | Inquire with mk North America |
| 9        | Wear Strip                   | Inquire with mk North America |

NOTE: For adjusting the chain tensioning, please see the related section for details. When cleaning the chain, avoid any harsh chemicals or detergents.

7 CONVEYOR BELT MAINTENANCE - TENSIONING & TRACKING



All work to be performed by qualified personnel only.

7.1 Idler/Tail 01

15

General Remarks:

- Belts may need to be tracked due to shifting during shipping.
- Prior to delivery of the mk conveyor, the chain was tensioned and tracked at the factory.
- Belt pretension conveyor length x 0.3%.
- Alternate tightening set screws AND loosen the other side as applicable in order to avoid over tensioning the belt.
- Belt tracking should only be done at the idler end.

Tensioning and tracking is done while the conveyor is in operation. Use extreme caution of all pinch, pull and other hazards.

7 CONVEYOR BELT MAINTENANCE - TENSIONING & TRACKING (CONT.)

7.1 Idler/Tail 01

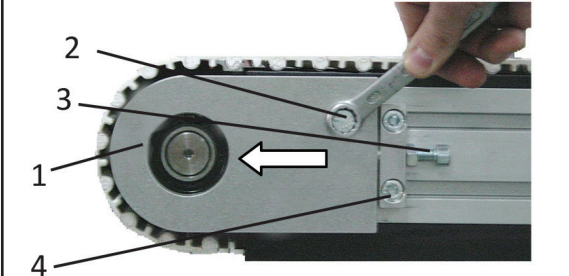
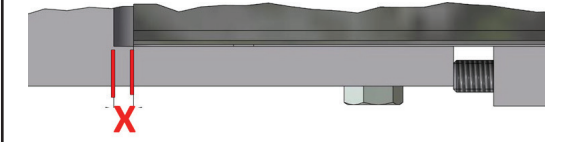
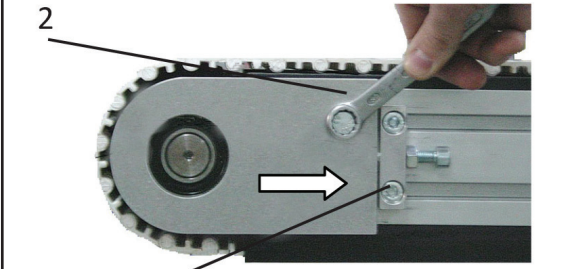

All work to be performed by qualified personnel only.

|  |   |
|--|---|
| <p><u>Belt Tensioning</u></p> <p><b>Caution!</b></p> <p><i>Belt tensioning is only to be done at the tail end (opposite the drive end).</i></p> <p>General Instructions:</p> <p>Loosen screw (2) and (4) to move tension blocks and complete tail assembly (1) out (arrow direction) in order to pretension the belt. Tighten screw (4) and, using the fine adjustment set screw (3), continue to tension the belt until correct tension is achieved. Finally, tighten screw (2) and move alignment block back into ready position.</p> <p>Fine-tune belt travel (see Belt Tracking, below).</p> |    |
| <p><u>Removing Belt Link:</u></p> <p><b>Caution!</b></p> <p><i>Link removal is only to be done at the tail (opposite the drive end).</i></p> <p>If X is greater than or equal to 17.7 mm, then remove 1 link from the belt. See instructions in belt manufacturer's manual instructions on removal.</p>  |  |
| <p><u>Belt Tracking</u></p> <p><b>Caution!</b></p> <p>Tracking (or realignment) of the belt must only be done while the belt is moving (pinch points).</p> <p>To track the belt, loosen screw (2). Turn the fine adjustment set screw (3) at the tail, until the belt has centered itself on the tail drum. Finally, retighten screw (2) and move alignment block back into ready position.</p>  |  |



8 CONVEYOR MAINTENANCE - BELT REPLACEMENT



All work to be performed by qualified personnel only.  
Conveyor power **must** be disconnected before replacing the belt.

8.1 Idler/Tail 01

17

General Remarks:

- Prior to replacing the belt, the tail assembly must be completely loosened and retracted - instructions for this are below.
- Any interfering parts must also be removed.
- When using an endless belt replacement belt, at least one side of the conveyor must be free and clear of stands, rails, and other accessories. This should be on the side opposite to the motor mount.
- Reassemble in reverse order.
- Replacement belts must be tracked and tensioned prior to use (see Section 7).

8 CONVEYOR MAINTENANCE - BELT REPLACEMENT

(CONT.)

8.1 Idler/Tail 01



All work to be performed by qualified personnel only.

Always remove links at the idler end of the conveyor.

If maximum chain tension is reached remove three (3) rows of links from the plastic modular belt.

Loosen screw (1).

Loosen screw (5) until the alignment block (4) fully rests on the roll holder (2).

Loosen both screws (3).

Move the roll holder (2) and alignment block (4) to the center position (in the direction of the arrow).

Tighten all screws (1) and (3).

Refer to the belt manufacturer's instructions for removing links from belt (8). Remove three links.

Refer to belt manufacturer's instructions to join open ends of belt together.

Reassemble in reverse order.

Tension belt, as outlined in Section 7.2, prior to operating conveyor.

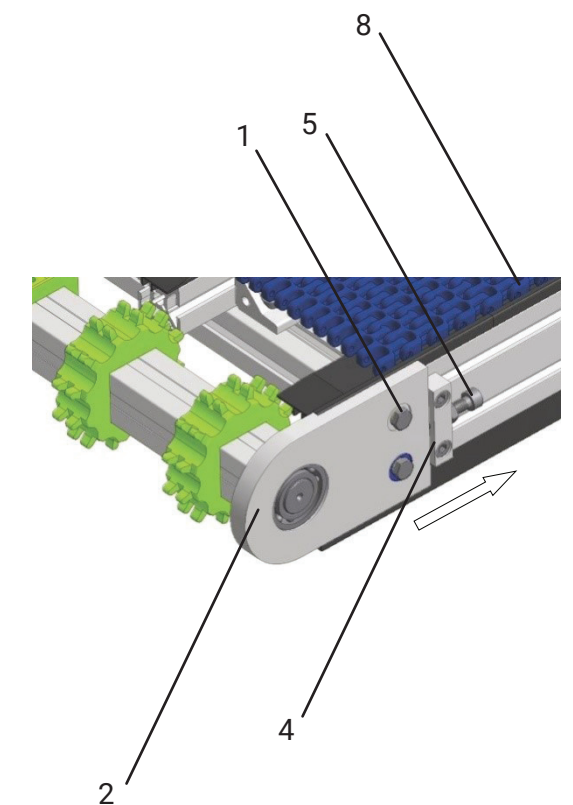

The belt can now be removed. Replace the belt and reassemble in reverse order. Track and tension the belt as show in Section 7 prior to use. Do not operate conveyor without all guards in place.

9 CONVEYOR MAINTENANCE - TENSIONING & GREASING OF DRIVE CHAIN

 All work to be performed by qualified personnel only.  
Conveyor power **must** be disconnected before performing maintenance.

|     |               |    |
|-----|---------------|----|
| 9.1 | KFM-P 2040 AC | 19 |
| 9.2 | KFM-P 2040 AS | 20 |

9 CONVEYOR MAINTENANCE - TENSIONING & GREASING OF DRIVE CHAIN (CONT.)

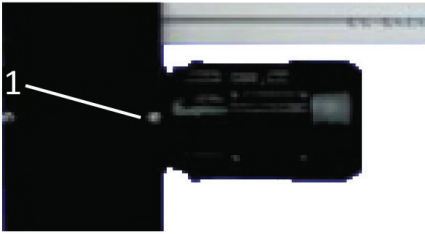
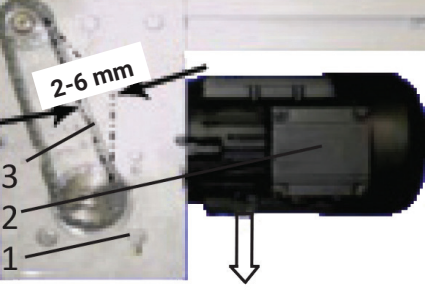
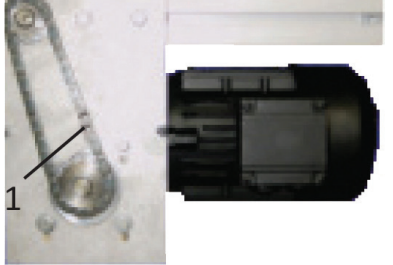

9.1 Tensioning & Greasing of the Drive Chain - KFM-P 2040 AC

|   |   |
|---|---|
| <p>Remove cap nuts (1) and remove the chain guard.</p>  |    |
| <p>Loosen the mounting screws (1) of the motor (2). Lower the motor, thereby adding tension to the drive chain (3).<br/><br/>Do not over-tension the drive chain. Proper tension should allow 2-6 mm of chain movement on one side.</p>   |   |
| <p><u>Greasing the Drive Train</u><br/>The drive chain (1) must be lubricated with grease in accordance with the maintenance instructions (see Section 6). Apply the lubricant with a brush to the chain edges, in order for the lubricant to penetrate the links completely.</p> |  |

\*Reassemble in reverse order; ensuring all screws are tight and all guards are in place before operating.

9 CONVEYOR MAINTENANCE - TENSIONING & GREASING OF DRIVE CHAIN (CONT.)

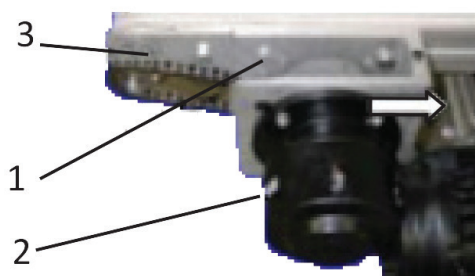
9.2 Tensioning & Greasing of the Drive Chain - KFM-P 2040 AS

|   |  |
|---|--|
| <p>Loosen bolt (1) at the upper and lower surface and remove the protective cover.</p>  |    |
| <p>Loosen fastening screws (1) of the gearmotor (2). Tighten the drive chain (3) by pushing the gearmotor downwards. In this procedure, be careful not to tighten the drive chain too much. The chain tension should be set between 2 and 6 mm.</p>   |   |
| <p><u>Greasing the Drive Train</u><br/>The drive chain (1) must be lubricated with grease in accordance with the maintenance instructions (see Section 6). During greasing, the grease must be applied to the edge of the chain, for example, with a brush in order to guarantee that it penetrates the rack joint.</p> |  |

8 CONTACT INFORMATION



sales@mknorthamerica.com  
spareparts@mknorthamerica.com  
service@mknorthamerica.com



(860) 769-5500

Technical Documentation  
DTZ-P 2040  
Turntable

**mk North America, Inc.**  
an mk Technology Group Company  
105 Highland Park Drive  
Bloomfield, CT 06002, USA  
Phone: (860) 769-5500

[www.mknorthamerica.com](http://www.mknorthamerica.com)  
[sales@mknorthamerica.com](mailto:sales@mknorthamerica.com)

All rights reserved, information subject to change without notice. © 2024 mk North America, Inc.

REV. 2024.06.01