



# Technical Documentation

## ZRF-P 2010 TIMING BELT CONVEYOR

Each serial number is unique to that specific conveyor and provides mk North America with complete order details.

The conveyor serial number is located on the frame at the drive end of the conveyor. See section 2 for more details.

---

1	General Information	3
2	Serial Number Label	4
3	Conveyor Description	5
4	Warranty Information	7
5	Safety Requirements	8
6	Wear Items & Maintenance For Specific Drive & Tail Options	10
7	Conveyor Belt Maintenance - Tensioning & Tracking	22
8	Conveyor Belt Maintenance - Belt Replacement	24
9	Conveyor Maintenance - Tensioning & Greasing Of Drive Chain	26
10	Contact Information	30

## 1 GENERAL INFORMATION

### 1.1 Foreword

Congratulations on purchasing a conveyor from mk North America, Inc., a leading manufacturer of quality low profile conveyors. Our more than 30 years experience in material handling allows us to offer robust solutions with long life and reliable operation. We strive to make the best products in the industry even better and we are committed to making sure our customers get top notch support before, during, and after each and every sale.

### 1.2 The importance of reading your manual

Inside this manual you will find the instructions on how to set up and maintain your mk conveyor properly, as well as maximize its performance. Please take the time to read this manual and familiarize yourself with these set up and maintenance instructions. These instructions will help assure a long product life that requires a minimum amount of service and keeps your conveyor working at its maximum capacity.

### 1.3 If you need assistance

If you need assistance there are a variety of ways to get it. You can contact our customer service team Monday through Friday, 8am-5pm (Eastern Time) at (860) 769-5500. You can also visit our website for additional information and technical documentation at [www.mknorthamerica.com](http://www.mknorthamerica.com). In addition, your local representative can provide support in many instances.

### 1.4 When your shipment arrives

- 1) Check your shipment
  - a) If you have not already done so, visually inspect the shipping crate/container for any damage caused during shipment.
  - b) Carefully unpack the crate/container making sure to inspect the components for damage that may have occurred inside the packaging materials.
  - c) If you find any damage, please contact the carrier and mk North America, Inc.
  - d) Lastly, check the contents against the packing slip provided by mk for any discrepancies. If you should find any, please contact mk North America, Inc.
- 2) Locate your ordered items
  - a) Each mk conveyor will ship in its own custom built container, carefully packaged in the most economical way.
  - b) Review the packing slip against your Purchase Order.

## 2 SERIAL NUMBER LABEL

- The conveyor's serial number is located on the frame at the drive end of the conveyor.

	Type:		Date:	
	Serial #:		CO #:	
	Drawing #:			
	www.mknorthamerica.com    (860) 769-5500			Scan for Documentation

### Type:

This description refers to the type of unit that is associated with the particular serial number. The type should NOT be substituted for the serial number when inquiring.

### Serial #:

This number is unique to this item. With this number we can access all of the original order details.

### Drawing #:

This number, if applicable, refers to the specific drawing that was created for this unit.

### Date:

This is the date that the unit was scheduled to ship.

### CO#:

This is the customer order number in which this unit was built. This is an mk North America, Inc. internal number. This number is also referenced on any related invoices, etc.

### Scan for Documentation:

Scanning this QR code will bring you to a webpage specific for the conveyor on this order. From here you can access drawings and spare parts.

## 3 CONVEYOR DESCRIPTION

### 3.1 Explaining the conveyor **TYPE**.

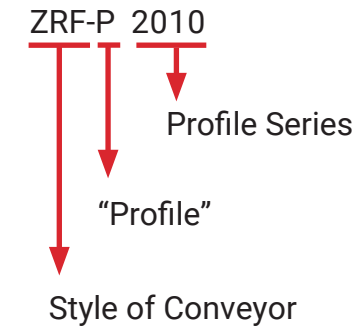

### Style of Conveyor

DGF (Doppel-Gurt Foerderer) Dual-Belt Conveyor

GUF (Gurt Foerderer) Belt Conveyor

KFG (Knickfoerderer Gurt) Bent "Gooseneck" Belt Conveyor

KFM (Knickförder Modular) Bent "Gooseneck" Plastic Modular Belt Conveyor

KGF (Kurvengurt Foerderer) Curve Belt Conveyor

KMF (Kurvengängiges Modulband) Curved Modular Belt Conveyor

KTF (Kettengurt Foerderer) Chain Conveyor

MBF (Modulband Foerderer) Modular Belt Conveyor

RBM (Rollenbahn Motor) Motorized Roller Conveyor

RBS (Rollenbahn Schwerkraft) Idler Roller Conveyor

RBT (Rollenbahn Tangentialkette) Drive Roller Conveyor

SBF (Scharnierband Foerderer) Hinged Belt Conveyor

SPU (Staufaehiges Pallettenumlaufsystem) Continuous Motion Pallet Conveyor

SRF (Staurollen Foerderer) Accumulating Roller Conveyor

TKU (Taktkettenförderer) Timing Chain Conveyor

ZRF (Zahnriemen Förderer) Timing Belt Conveyor

### 3 CONVEYOR DESCRIPTION (CONT.)

#### 3.2 Conveyor Components

The ZRF-P 2010 has many typical conveyor components. Below is a description of the basic parts and options for the ZRF-P 2010 conveyor. The items you receive will vary based on your actual purchase order. Items may appear different on your model based on your particular order requirements. Consult your approval drawing for specific items included in your order.

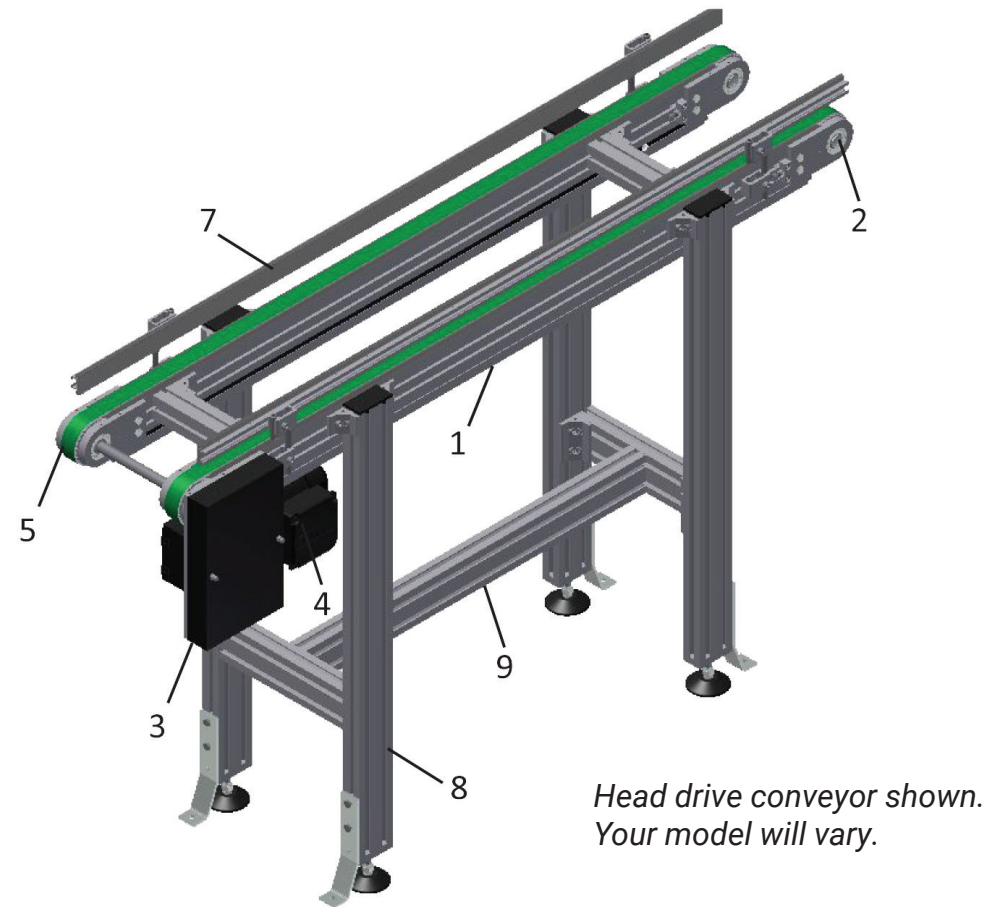

#### Typical Components

- 1) Conveyor Frame
- 2) Idler End
- 3) Gearmotor Mount/Drive Assembly
- 4) Gearmotor
- 5) Timing Belt
- 6) Controller (Not shown)
- 7) Side Rails
- 8) Support Stand
- 9) Stand Stringer

### 4 WARRANTY INFORMATION

#### Warranty

mk North America, Inc. (MKNA) offers a COMPLETE ONE YEAR WARRANTY from the date of delivery, to the original purchaser of the MKNA equipment (CUSTOMER), to be free from defects in material and workmanship; under normal use and with proper installation, maintenance and cleaning.

Additionally MKNA offers a LIMITED 10 YEAR WARRANTY on all equipment that MKNA is the original manufacturer of, to be free from defect and workmanship.<sup>1</sup>

This warranty is extended by MKNA only to CUSTOMER, and is non-transferable. All warranty requests shall be made by CUSTOMER.

MKNA will replace or repair, at our factory or any other location we designate<sup>2</sup>, any defective part within the warranty period and without charge. It is at MKNA's sole discretion whether to repair or replace. CUSTOMER will provide MKNA with a prompt written notice of the defect, including the serial number of the unit (when applicable) and the date of delivery.

At MKNA's request CUSTOMER will return all defective parts for evaluation at MKNA. MKNA will provide CUSTOMER with a return goods authorization number (RGA#). No parts will be returned without a RGA#. The RGA# must clearly be marked on all labels, packages and packing slips.

CUSTOMER shall pay all costs for packaging, shipping, duties and/or any other related costs in the sending or receiving of parts. CUSTOMER is responsible for all labor associated with sending or receiving of parts.

MKNA PROVIDES NO WARRANTY OF MERCHANTABILITY OR FITNESS FOR A PARTICULAR PURPOSE; UNLESS IT IS AGREED TO BY MKNA AND CUSTOMER IN WRITING PRIOR TO PLACEMENT OF ORDER. Such agreement requires approval of MKNA Management.

UNDER NO CIRCUMSTANCES SHALL MKNA BE HELD LIABLE FOR DAMAGES OR LIABILITY FOR LOSS OF PRODUCTION, PRODUCT, EQUIPMENT OR PROFITS OR LIABILITY FOR DIRECT, INCIDENTAL, INDIRECT, SPECIAL OR CONSEQUENTIAL DAMAGES OR ANY DAMAGES TO PERSONS OR PROPERTY, WHATSOEVER. CUSTOMER agrees that it is their sole remedy for liability of any kind, including negligence with respect to the equipment and services furnished by MKNA shall be limited to the remedies provided herein. This warranty shall not apply to any failure of the unit or its components caused by lack of maintenance and/or improper maintenance, incorrect adjustments, misuse or unreasonable use or exposure to chemicals and/or environments which the unit is not designed for. Unauthorized modification of the unit or the use of non-MKNA replacement parts and building components voids this warranty.

<sup>1</sup> The limited 10 year warranty does not apply to equipment and components manufactured by others. Such equipment and components are subject to any limitation contained in the original manufacturer's warranty and include, but are not limited to: bearings, belts, casters, controllers, motors and pneumatic devices.

<sup>2</sup> No work will be performed by MKNA or an MKNA factory authorized service representative at the site of installation unless in MKNA's opinion it is impractical for Customer to remove and return the defective part to MKNA's factory.

EXCEPT AS EXPRESSLY STATED HEREIN, THERE ARE NO WARRANTIES, EXPRESSED OR IMPLIED, BY OPERATION OF LAW OR OTHERWISE, OF THE EQUIPMENT OR SERVICES FURNISHED BY MKNA OR FACTORY AUTHORIZED SERVICE REPRESENTATIVE. THERE ARE NO WARRANTIES WHICH EXTEND BEYOND THE DESCRIPTION ON THE FACE HEREOF.

mk North America, Inc. reserves the right to change, modify or discontinue products and/or specifications with or without notice.

All of mk North America, Inc. products are covered by this warranty.

5 SAFETY REQUIREMENTS

5.1 Warnings - Safety Guidelines

READ AND UNDERSTAND ALL OF THESE WARNINGS PRIOR TO OPERATING EQUIPMENT.

**CAUTION**



Read this manual before operating conveyors.

**CAUTION**



Never operate or service equipment under the influence of drugs and/or alcohol.

**CAUTION**



Lock out power before servicing the conveyor.

**WARNING**



Do NOT operate conveyors without guards in place.  
Severe injury can occur.

**IMPORTANT**



Conveyors must be installed so that they are square and level – across the belt. Failure to install conveyors correctly may cause premature equipment failure and/or product damage.

**WARNING**



Do not operate conveyors in an explosive environment.

**DANGER**



Moving equipment can cause severe injury or death.  
Do NOT touch moving parts. Lock out power before servicing.

**WARNING**



Gearmotors will be hot. Do NOT touch.  
Severe injury can occur.

**DANGER**



Climbing, sitting, walking or riding on the conveyor at any time could result in severe injury or death.  
KEEP OFF!

**DANGER**



Always support conveyor sections prior to loosening stands or supports. Loosening stands or supports can cause the conveyor to fall creating a crush hazard.

5 SAFETY REQUIREMENTS

(CONT.)

**NOTICE**



All work should be done by qualified professionals. This includes electricians for all wiring.

6 WEAR ITEMS & MAINTENANCE FOR SPECIFIC DRIVE OPTIONS

6.1	Important Notes About Wear Items & Maintenance	11
6.2	ZRF-P 2010 AA	12
6.3	ZRF-P 2010 AC	14
6.4	ZRF-P 2010 AS	16
6.5	ZRF-P 2010 BC	18

6 WEAR ITEMS & MAINTENANCE FOR SPECIFIC DRIVE OPTIONS (CONT.)

6.1 Important Notes About Wear Items & Maintenance

The following information regarding life of the wear items and service or adjustment intervals of the functional elements are only GUIDELINES. Conveyors are application-specific products whose life expectancy can vary depending on their relative loads and speeds, and which can be significantly influenced by environmental factors.

- All moving components and screw connections should be checked every 6 months.
- All safety-relevant components should be part of a regularly scheduled weekly inspection
- The proper function of these components must be confirmed at all times.
- Do NOT operate conveyors if safety-relevant components are damaged or missing.
- All parts which contact the product should be cleaned weekly (example: belt).
- Belts require little special care. They are easily cleaned using lukewarm soapy water.
- Remove heavy grease coatings with ethyl alcohol.
- Blow off debris from belts with structured surfaces using compressed air.

6 WEAR ITEMS & MAINTENANCE FOR SPECIFIC DRIVE OPTIONS (CONT.)

6.2 ZRF-P 2010 AA

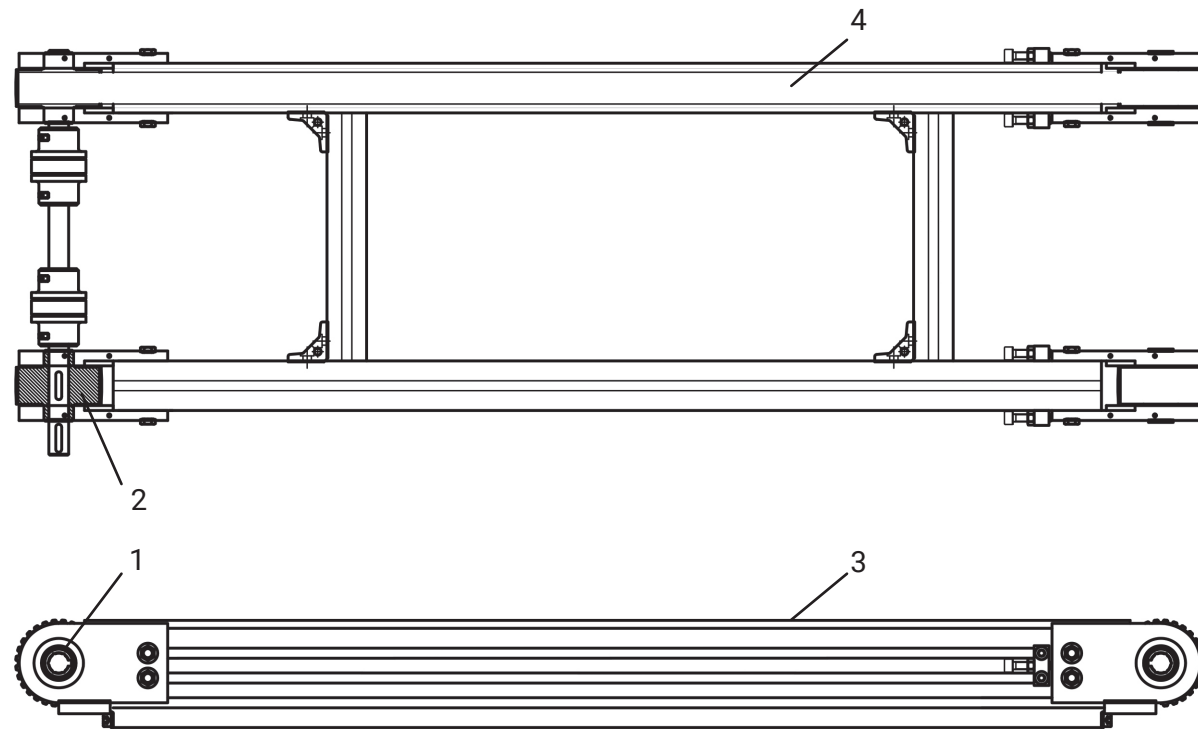

NOTE: Not all items shown in all views for clarity.

(Cont.)

6 WEAR ITEMS & MAINTENANCE FOR SPECIFIC DRIVE OPTIONS (CONT.)

6.2 ZRF-P 2010 AA (Cont.)

Maintenance Work for ZRF-P 2010 AA

Position	Description	Action*	Interval in Hours (Months)
1	Roller Bearing	I	1,000 Hours (Max. 6 Months)
2	Drive/Idler Sprocket	I, C	500 Hours (Max. 3 Months)
3	Wear Strip	I, C	500 Hours (Max. 3 Months)
		R	If wear is visible
4	Timing Belt	I, C	500 Hours (Max. 3 Months)
		R	If wear is visible

\* LEGEND: Inspect, Replace, Tension, Clean, Lubricate (grease).

Wear Items for ZRF-P 2010 AA

Position	Description	Part Number
1	Roller Bearing 6006-2RS1	K101001316
2	Drive/Idler Sprocket	58.01.0024
3	Wear Strip	Inquire with mk North America
4	Belt	Inquire with mk North America

6 WEAR ITEMS & MAINTENANCE FOR SPECIFIC DRIVE OPTIONS (CONT.)

6.3 ZRF-P 2010 AC

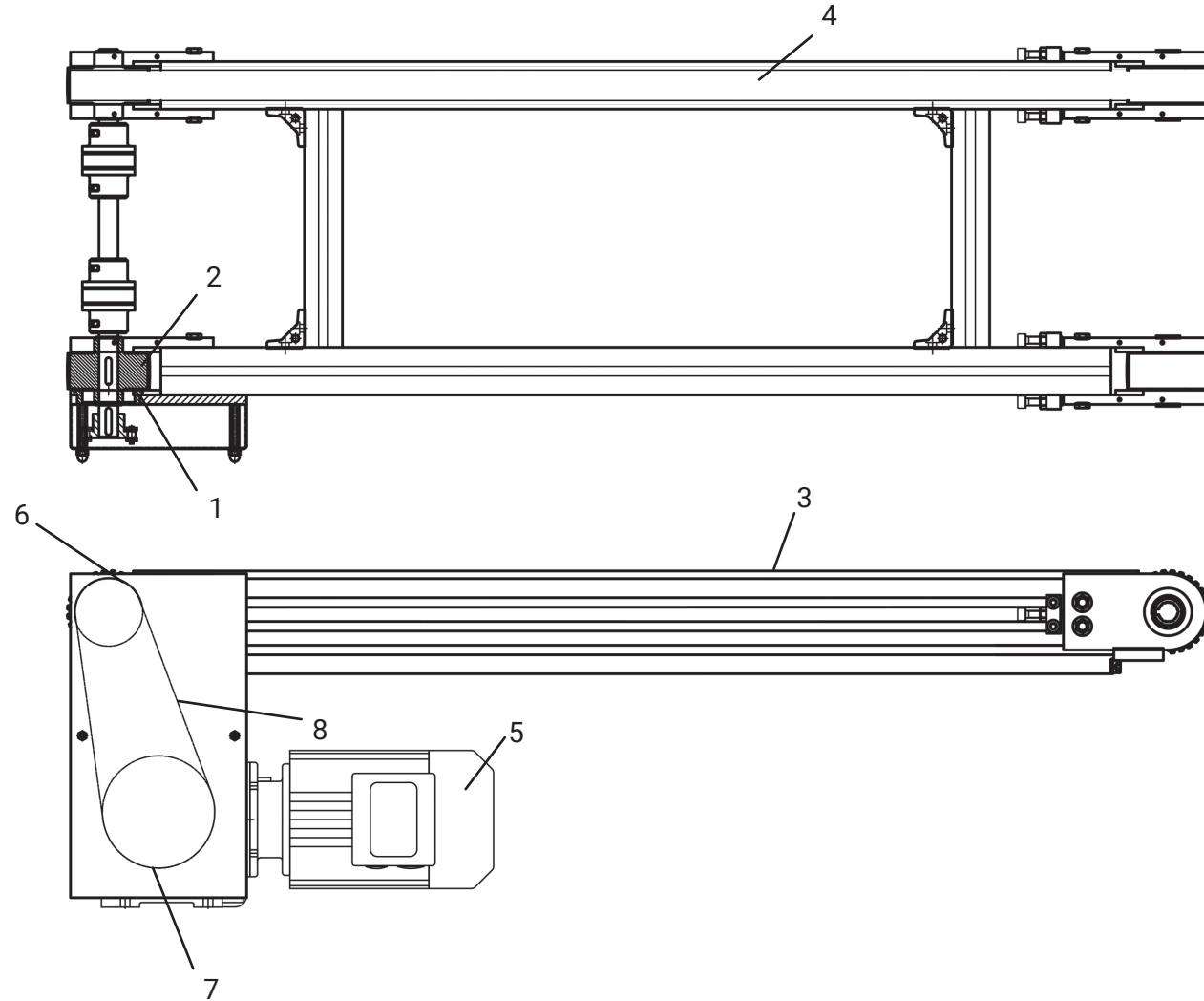

NOTE: Not all items shown in all views for clarity.

(Cont.)

6 WEAR ITEMS & MAINTENANCE FOR SPECIFIC DRIVE OPTIONS (CONT.)

6.3 ZRF-P 2010 AC (Cont.)

Maintenance Work for ZRF-P 2010 AC

Position	Description	Action*	Interval in Hours (Months)	Lubrication
1	Roller Bearing	I	1,000 Hours (Max. 6 Months)	
2	Drive/Idler Sprocket	I, C	500 Hours (Max. 3 Months)	
3	Wear Strip	I, C	500 Hours (Max. 3 Months)	
		R	If wear visible	
4	Timing Belt	I, C	500 Hours (Max. 3 Months)	
		R	If wear visible	
5	Gearmotor	I, C	Service & maintenance per manufacturer's documentation	
6 & 7	Drive Train Sprockets	I, C	500 Hours (Max. 3 Months)	SAE20-SAE50
8	Drive Train Chain	I, C, T, L	500 Hours (Max. 3 Months)	SAE20-SAE50
		R	If chain stretch is greater than 3%	

\* LEGEND: Inspect, Replace, Tension, Clean, Lubricate (grease).

Wear Items for ZRF-P 2010 AC

Position	Description	Part Number
1	Roller Bearing 6006-2RS1	K101000428
2	Drive/Idler Sprocket	58.01.0024
3	Wear Strip	Inquire with mk North America
4	Belt	Inquire with mk North America
5	Gearmotor	Inquire with mk North America
6	Sprocket at Drive Roll	Inquire with mk North America
7	Sprocket at Gearmotor	Inquire with mk North America
8	Chain & Connecting Link	Inquire with mk North America

NOTE: For adjusting the chain tensioning, please see the related section for details. When cleaning the chain, avoid any harsh chemicals or detergents.



6 WEAR ITEMS & MAINTENANCE FOR SPECIFIC DRIVE OPTIONS (CONT.)

6.3 ZRF-P 2010 AF

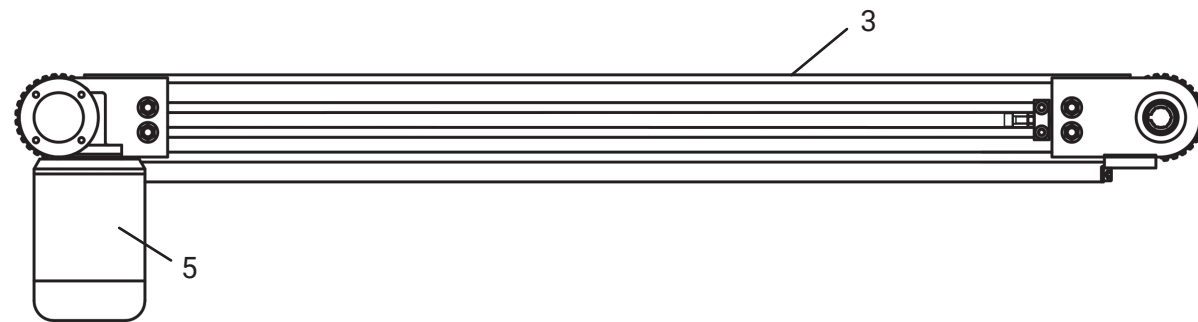
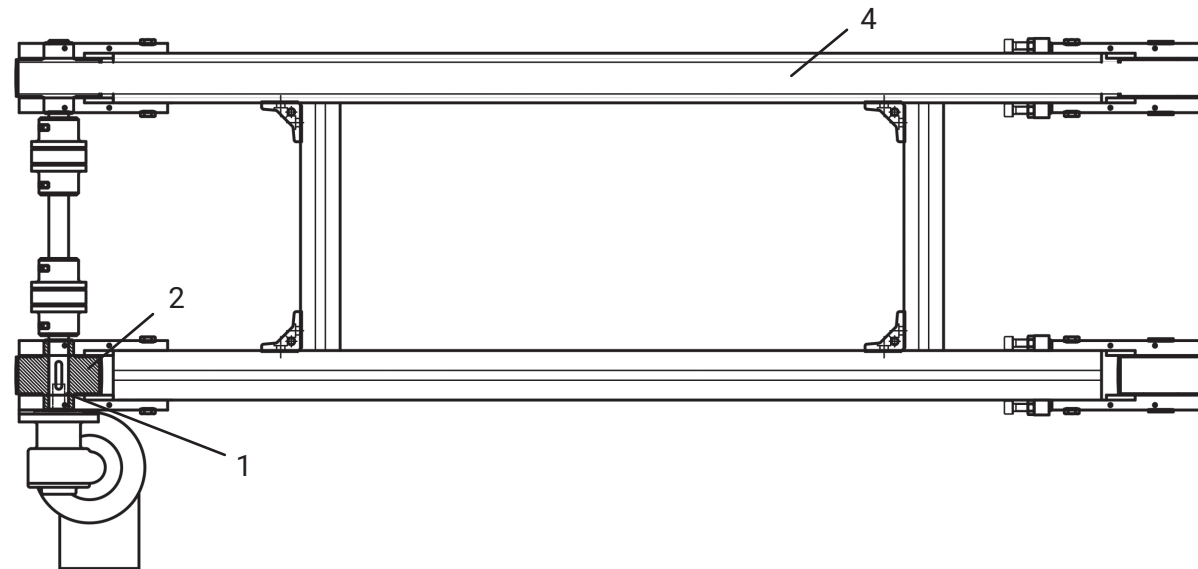

NOTE: Not all items shown in all views for clarity.

(Cont.)

6 WEAR ITEMS & MAINTENANCE FOR SPECIFIC DRIVE OPTIONS (CONT.)

6.3 ZRF-P 2010 AF (Cont.)

Maintenance Work for ZRF-P 2010 AF

Position	Description	Action*	Interval in Hours (Months)
1	Roller Bearing	I	1,000 Hours (Max. 6 Months)
2	Drive/Idler Sprocket	I, C	500 Hours (Max. 3 Months)
3	Wear Strip	I, C	500 Hours (Max. 3 Months)
		R	If wear is visible
4	Timing Belt	I, C	500 Hours (Max. 3 Months)
		R	If wear is visible
5	Gearmotor	I, C	Service & maintenance per manufacturer's documentation

\* LEGEND: *Inspect, Replace, Tension, Clean, Lubricate (grease).*

Wear Items for ZRF-P 2010 AC

Position	Description	Part Number
1	Roller Bearing 6006-2RS1	K101001316
2	Drive/Idler Sprocket	58.01.0024
3	Wear Strip	Inquire with mk North America
4	Belt	Inquire with mk North America
5	Gearmotor	Inquire with mk North America

NOTE: For adjusting the chain tensioning, please see the related section for details. When cleaning the chain, avoid any harsh chemicals or detergents.

6 WEAR ITEMS & MAINTENANCE FOR SPECIFIC DRIVE OPTIONS (CONT.)

6.4 ZRF-P 2010 AS

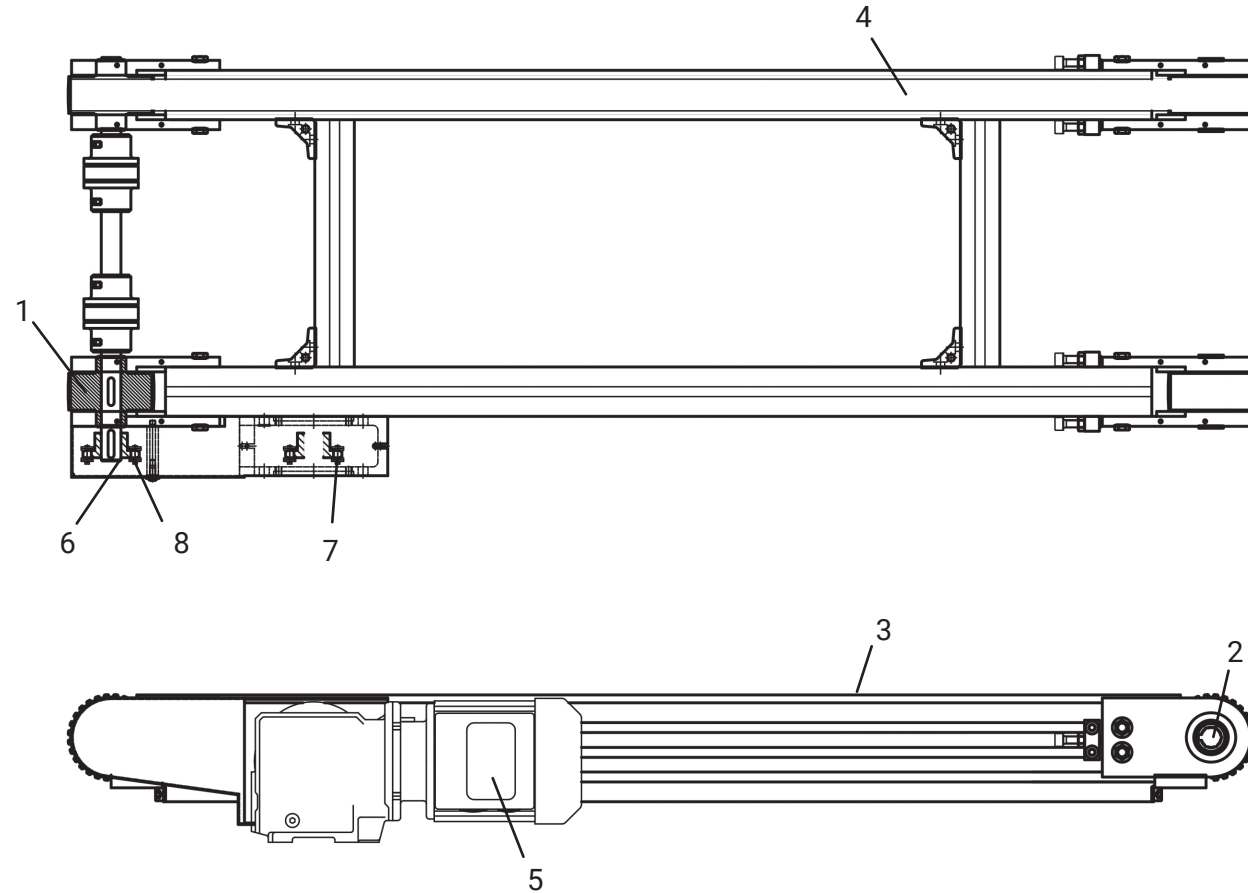

NOTE: Not all items shown in all views for clarity.

(Cont.)

6 WEAR ITEMS & MAINTENANCE FOR SPECIFIC DRIVE OPTIONS (CONT.)

6.4 ZRF-P 2010 AS (Cont.)

Maintenance Work for ZRF-P 2010 AS

Position	Description	Action*	Interval in Hours (Months)	Lubrication
1	Roller Bearing	I	1,000 Hours (Max. 6 Months)	
2	Drive/Idler Sprocket	I, C	500 Hours (Max. 3 Months)	
3	Wear Strip	I, C	500 Hours (Max. 3 Months)	
		R	If wear visible	
4	Timing Belt	I, C	500 Hours (Max. 3 Months)	
		R	If wear visible	
5	Gearmotor	I, C	Service & maintenance per manufacturer's documentation	
6 & 7	Drive Train Sprockets	I, C	500 Hours (Max. 3 Months)	SAE20-SAE50
8	Drive Train Chain	I, C, T, L	500 Hours (Max. 3 Months)	SAE20-SAE50
		R	If chain stretch is greater than 3%	

\* LEGEND: Inspect, Replace, Tension, Clean, Lubricate (grease).

Wear Items for ZRF-P 2010 AS

Position	Description	Part Number
1	Roller Bearing 6006-2RS1	K101000428
2	Drive/Idler Sprocket	58.01.0024
3	Wear Strip	Inquire with mk North America
4	Belt	Inquire with mk North America
5	Gearmotor	Inquire with mk North America
6	Sprocket at Drive Roll	Inquire with mk North America
7	Sprocket at Gearmotor	Inquire with mk North America
8	Chain & Connecting Link	Inquire with mk North America

NOTE: For adjusting the chain tensioning, please see the related section for details. When cleaning the chain, avoid any harsh chemicals or detergents.

6 WEAR ITEMS & MAINTENANCE FOR SPECIFIC DRIVE OPTIONS (CONT.)

6.5 ZRF-P 2010 BC

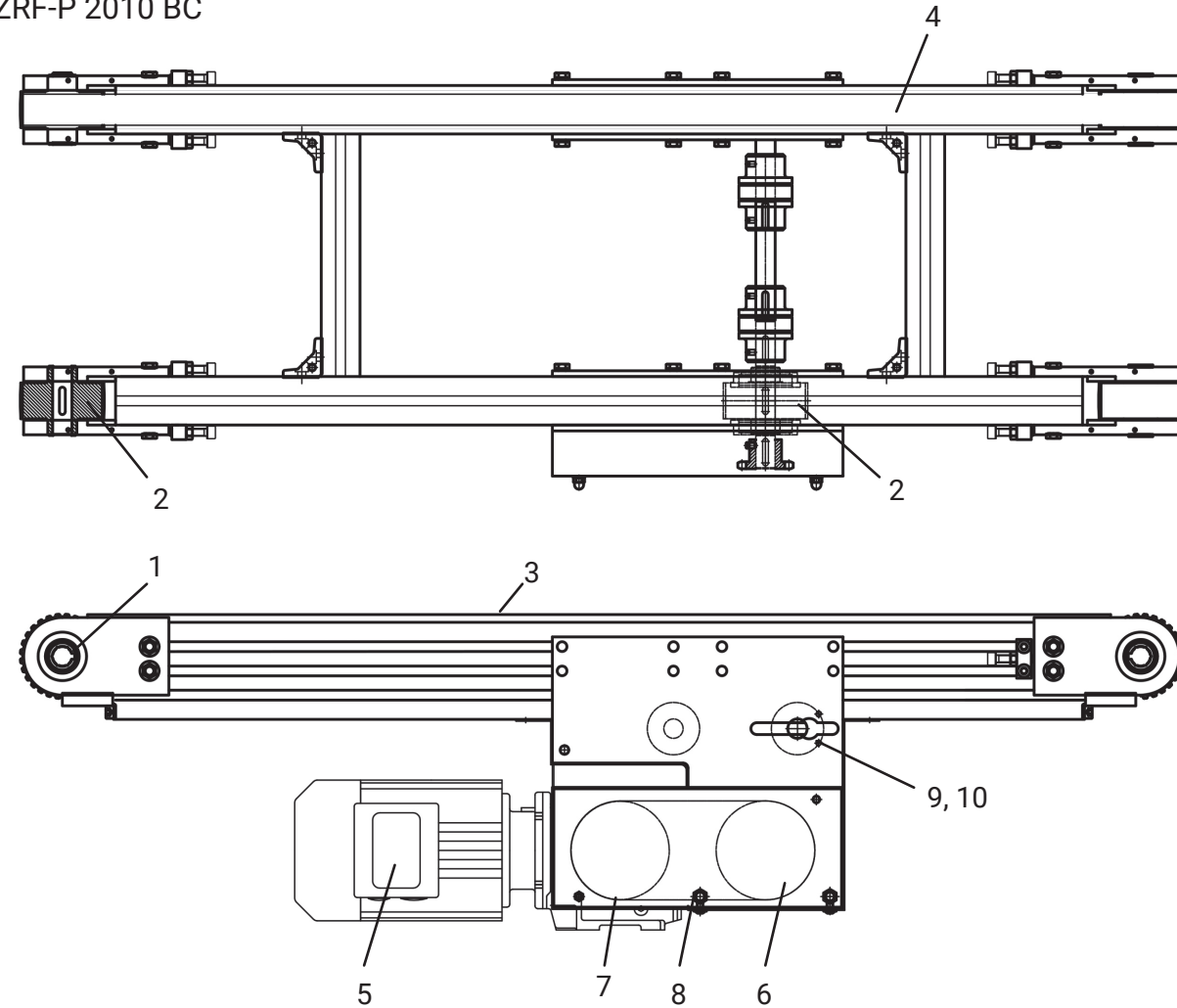

NOTE: Not all items shown in all views for clarity.

(Cont.)

6 WEAR ITEMS & MAINTENANCE FOR SPECIFIC DRIVE OPTIONS (CONT.)

6.5 ZRF-P 2010 BC (Cont.)

Maintenance Work for ZRF-P 2010 BC

Position	Description	Action*	Interval in Hours (Months)	Lubrication
1	Roller Bearing	I	1,000 Hours (Max. 6 Months)	
2	Drive/Idler Sprocket	I, C	500 Hours (Max. 3 Months)	
3	Wear Strip	I, C	500 Hours (Max. 3 Months)	
		R	If wear visible	
4	Timing Belt	I, C	500 Hours (Max. 3 Months)	
		R	If wear visible	
5	Gearmotor	I, C	Service & maintenance per manufacturer's documentation	
6 & 7	Drive Train Sprockets	I, C	500 Hours (Max. 3 Months)	SAE20-SAE50
8	Drive Train Chain	I, C, T, L	500 Hours (Max. 3 Months)	SAE20-SAE50
		R	If chain stretch is greater than 3%	
9	Nip Drum, 2010 BC	I, C	500 Hours (Max. 3 Months)	
10	Roller Bearing	I, C	500 Hours (Max. 3 Months)	

\* LEGEND: Inspect, Replace, Tension, Clean, Lubricate (grease).

Wear Items for ZRF-P 2010 BC

Position	Description	Part Number
1	Roller Bearing 6006-2RS1	K101000428
2	Drive/Idler Sprocket	58.01.0024
3	Wear Strip	Inquire with mk North America
4	Belt	Inquire with mk North America
5	Gearmotor	Inquire with mk North America
6	Sprocket at Drive Roll	Inquire with mk North America
7	Sprocket at Gearmotor	Inquire with mk North America
8	Chain & Connecting Link	Inquire with mk North America
9	Nip Drum, 2010 BC	83.01.0013
10	Roller Bearing	K101000398

NOTE: For adjusting the chain tensioning, please see the related section for details. When cleaning the chain, avoid any harsh chemicals or detergents.

7 CONVEYOR BELT MAINTENANCE - TENSIONING & TRACKING



All work to be performed by qualified personnel only.  
Conveyor power must be disconnected before replacing the belt.

7.1 Standard Idler

23

General Remarks:

- Belts may need to be tracked due to shifting during shipping.
- Prior to delivery of the mk conveyor, the belt was tensioned and tracked at the factory.
- Belt pretension conveyor length = chain length x 0.1%.
- Belt tracking should only be done at the idler end.
- Avoid over tensioning the belt, increase slack in belt is necessary.

7 CONVEYOR BELT MAINTENANCE - TENSIONING & TRACKING (CONT.)

7.1 Standard Idler



All work to be performed by qualified personnel only.

Belt Tensioning

**Caution!**

*Belt tensioning is only to be done at the idler end (opposite the motor end).*

General Instructions:

- The belt was tensioned and adjusted at the factory before delivery of the mk product.

Loosen screws (2) and (4) to pull the entire assembly (1) out (arrow direction) in order to pretension the timing belt. Tighten screw (4) and then finally adjust the timing belt with screw (3), see below.

Tighten bolt (2).

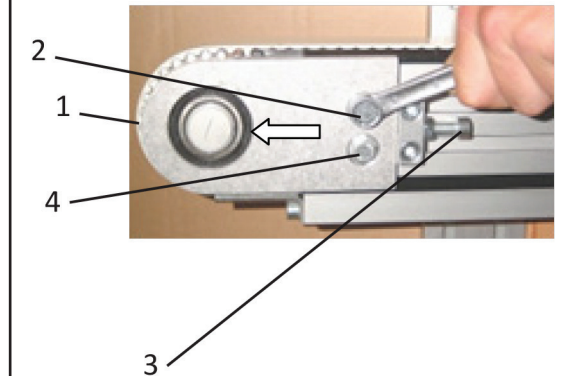

Belt Tracking

**Caution!**

*Tracking (or realignment) of the belt must only be done while the belt is moving (pinch points).*

Adjust bolt (2) and screw (3) in the direction of the arrow, for the fine adjustment to the timing belt until the belt is running centrally on the pulley. Tighten the bolt (2).

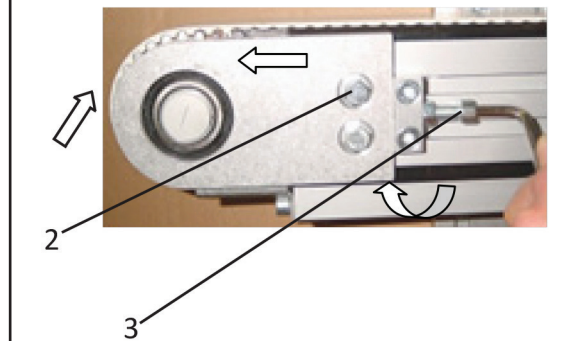

8 CONVEYOR BELT MAINTENANCE - BELT REPLACEMENT

 All work to be performed by qualified personnel only.  
Conveyor power must be disconnected before replacing the belt.

8.1 Standard Idler

25



General Remarks:

- Prior to replacing the belt, the tail assembly must be completely loosened and retracted – instructions for this to follow.
- Any interfering parts must be removed – instructions on this to follow.
- Any auxiliary parts that interfere must be removed. This includes supports pieces.
- One side of the conveyor must be free and clear of all interferences. This **MUST** be the side with the black cover strip.
- Reassemble in reverse order.
- Replacement belts must be tracked and tensioned prior to use. (See Section 7)

8 CONVEYOR BELT MAINTENANCE - BELT REPLACEMENT (CONT.)

 All work to be performed by qualified personnel only.

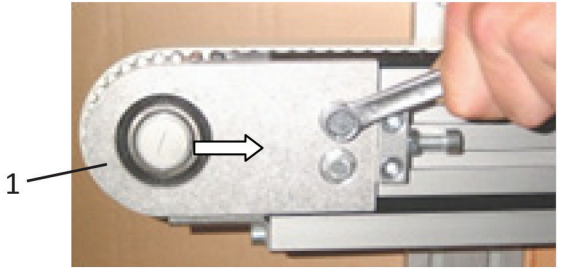
8.1 Standard Idler

<p>Loosen all bolts and push the entire head (1) inwards (in the direction of the arrow), in order to create slack in the timing belt.</p>	
<p>Remove the belt return guard (2) by removing all screws. Do this at BOTH ends of the conveyor.</p>	
<p>Remove the closure strip (3) by sliding the material out of the end. This will expose the belt return channel.</p>	

Removing the Belt:

- The belt can now be replaced once all auxiliary obstructions are removed.
- To replace belt, slip it over the side of the conveyor and fit into the return channel.
- Reassemble conveyor in the reverse order and the track and tension belt.

Additional Notes for ZRF-P 2010 BC:

Relax the nip drums (see Item 9 from Section 6) in their location. Once the side of the conveyor is exposed; the drive assembly needs to be disassembled in order to thread out the old belt. Do this on the same side as the closure strip (3) from above. Thread belt back through drive assembly and then over idlers.

9 CONVEYOR MAINTENANCE - TENSIONING & GREASING OF DRIVE CHAIN



All work to be performed by qualified personnel only.  
Conveyor power **must** be disconnected before performing maintenance.

THIS SECTION DOES NOT APPLY TO THE DRIVE VERSION AA.  
Do NOT lubricate timing belt and pulley drive trains.

9.1	ZRF-P 2010 AC	27
9.2	ZRF-P 2010 AS	28
9.3	ZRF-P 2010 BC	29

9 CONVEYOR MAINTENANCE - TENSIONING & GREASING OF DRIVE CHAIN

9.1 Tensioning & Greasing of the Drive Chain - ZRF-P 2010 AC

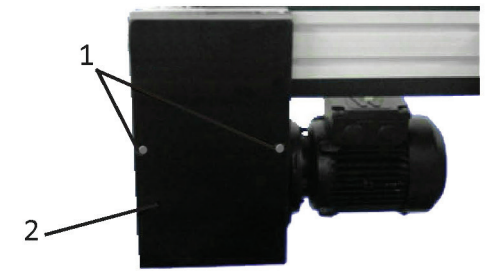
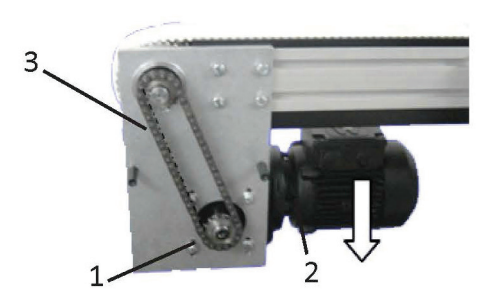
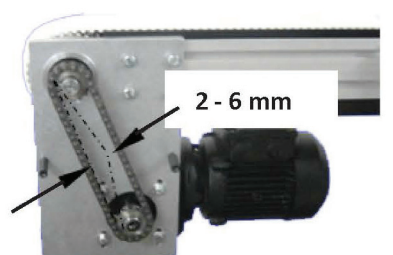
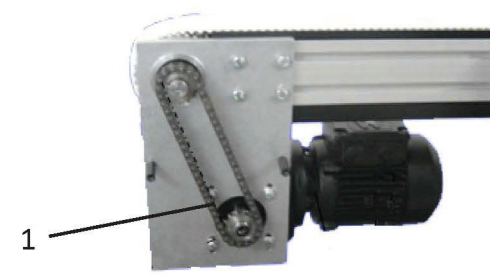
<p>Remove cap nuts (1) and remove chain guard (2).</p>	
<p>Loosen the motor mounting screws (1) - 4 places. Lower the motor (2), thereby adding tension to the drive chain (3).</p>	
<p>Do not over tension the drive chain. Proper tension should allow 2 to 6 mm of chain movement on the side.</p>	
<p><u>Greasing the Drive Train</u> The drive chain (1) must be lubricated with grease in accordance with the maintenance instructions (See Section 6). Apply the lubricant with a brush to the chain edges, in order for the lubricant to penetrate the links completely.</p>	

Note: Reassemble in reverse order; ensuring all screws are tight and all guards are in place before operating.

9 CONVEYOR MAINTENANCE - TENSIONING & GREASING OF DRIVE TRAIN (CONT.)

9.2 Tensioning & Greasing of the Drive Chain - ZRF-P 2010 AS

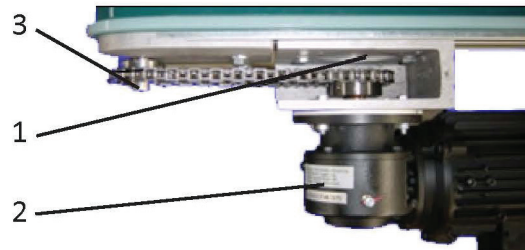
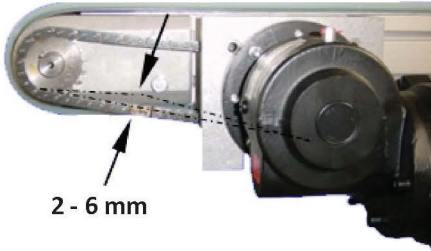
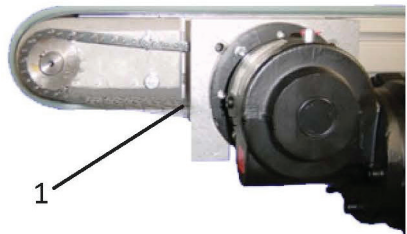
<p>Loosen bolts/screws on the upper and front surfaces of the drive train and remove cover.</p>	
<p>Loosen the motor mounting screws (1) - 4 places. Tighten the drive chain (3) by pushing the motor (2) downwards.</p>	
<p>Do not over tension the drive chain. Proper tension should allow 2 to 6 mm of chain movement on the side.</p>	
<p><u>Greasing the Drive Train</u> The drive chain (1) must be lubricated with grease in accordance with the maintenance instructions (See Section 6). Apply the lubricant with a brush to the chain edges, in order for the lubricant to penetrate the links completely.</p>	

Note: Reassemble in reverse order; ensuring all screws are tight and all guards are in place before operating.

9 CONVEYOR MAINTENANCE - TENSIONING & GREASING OF DRIVE TRAIN (CONT.)

9.3 Tensioning & Greasing of the Drive Chain - ZRF-P 2010 BC

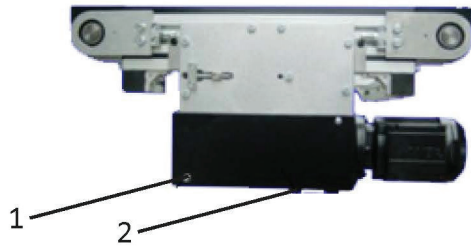
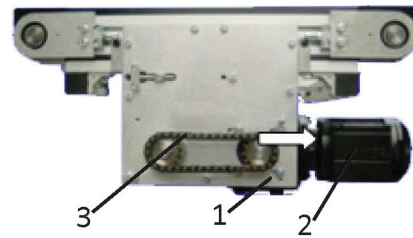
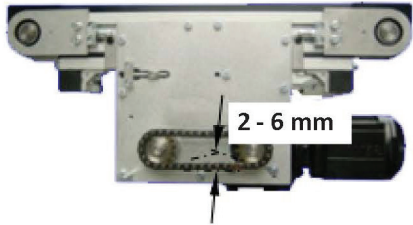
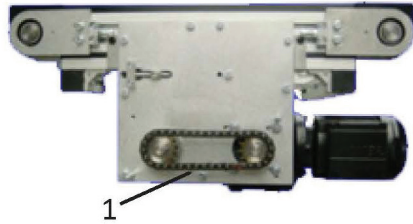
<p>Remove the drive train cover bolts (1) (various places) and remove the drive train cover (2).</p>	
<p>Loosen the motor mounting screws (1) - 4 places. Slide the motor (2) in the slots provided in the direction of the arrow, thereby adding tension to the drive chain (3).</p>	
<p>Do not over tension the drive chain. Proper tension should allow 2 to 6 mm of chain movement on the side.</p>	
<p><u>Greasing the Drive Train</u> The drive chain (1) must be lubricated with grease in accordance with the maintenance instructions (See Section 6). Apply the lubricant with a brush to the chain edges, in order for the lubricant to penetrate the links completely.</p>	

Note: Reassemble in reverse order; ensuring all screws are tight and all guards are in place before operating.

10 CONTACT INFORMATION

---



sales@mknorthamerica.com  
spareparts@mknorthamerica.com  
service@mknorthamerica.com



(860) 769-5500

**mk North America, Inc.**  
an mk Technology Group Company  
105 Highland Park Drive  
Bloomfield, CT 06002, USA  
Phone: (860) 769-5500

www.mknorthamerica.com  
sales@mknorthamerica.com