

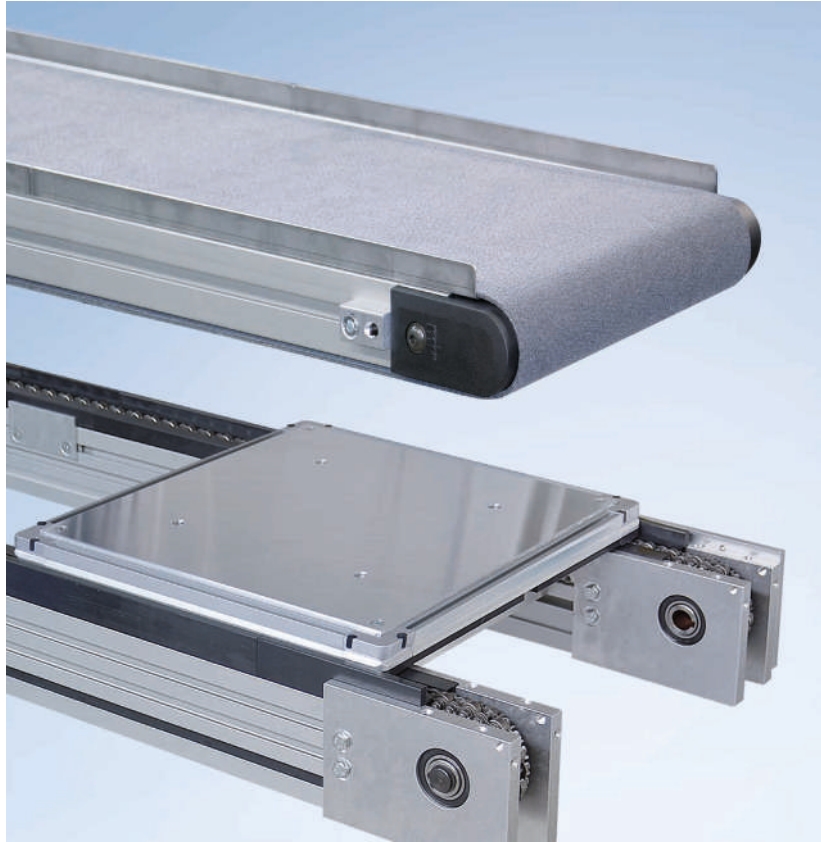

Conveyor Technology

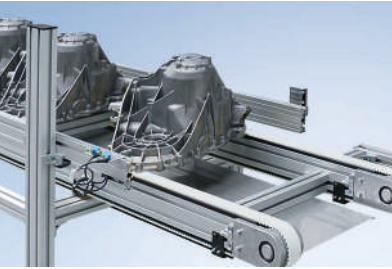

Conveyor Technology.
Linear Technology.

Modular Construction Kit for Factory Automation

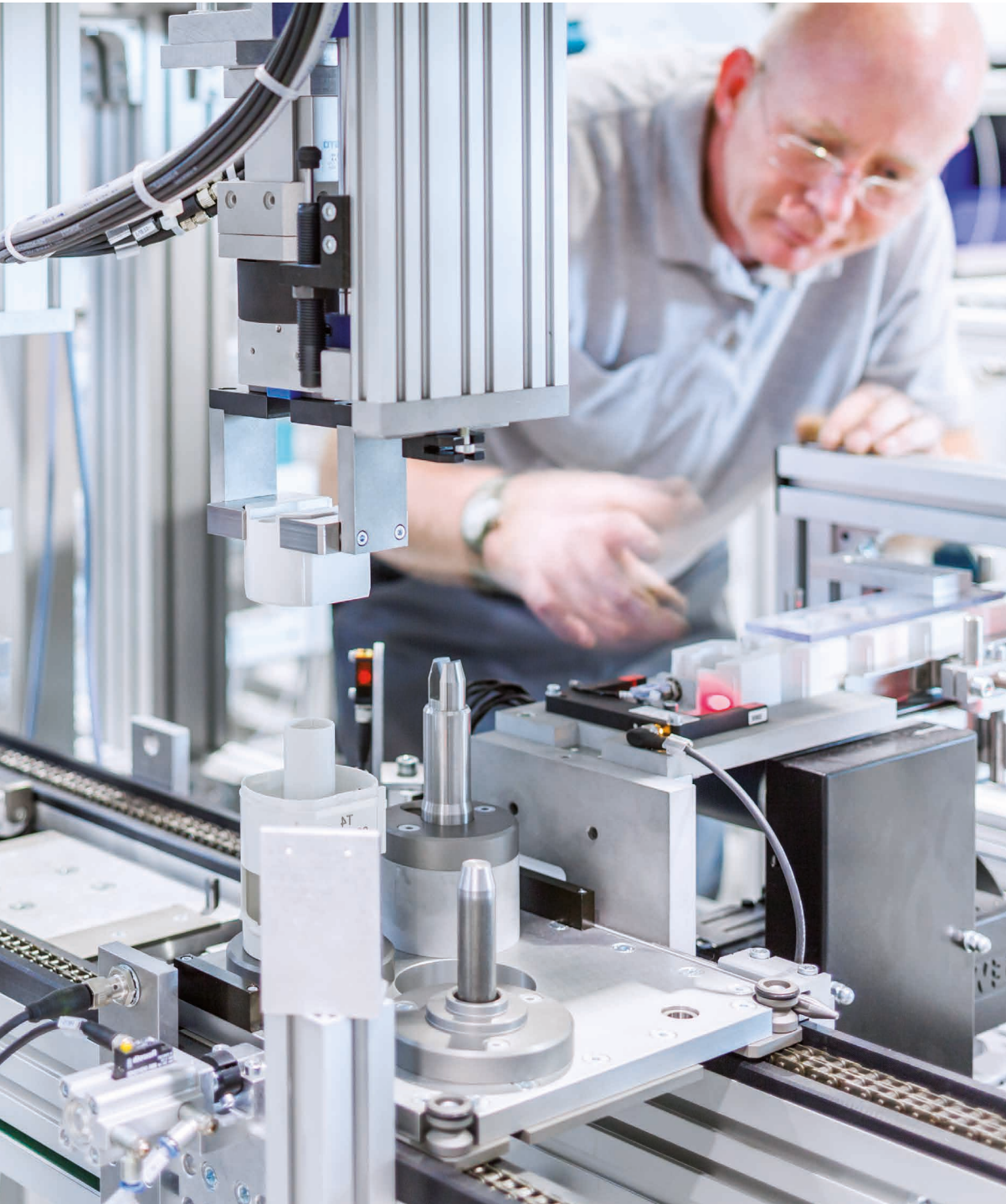

Profile Technology



» Components,
modules and solutions for
factory automation. «

Conveyor Technology



Maschinenbau Kitz, the parent company of the mk Technology Group, was founded in 1966 in Troisdorf, near Bonn, Germany. mk is one of the leading suppliers of components, modules and systems for factory automation.

Our portfolio of profile technology includes workstation set-ups, guarding and custom-designed machine frames and platforms, in addition to the aluminium profile system on which they are based.

System Solutions



In the field of conveyor technology, mk offers an extensive range of standardised conveyor types, supplemented with linear technology for precision handling applications.

Furthermore, mk is on hand to assist its customers with system solutions, from project planning and design to the commissioning of complete transfer systems.

Our services round off the product portfolio and include repairs, maintenance and a spare parts supply service.

Services



With our deep production, sales and service network consisting of subsidiaries, sales partners and external service providers, we guarantee our customers fast access to our expert advice and outstanding products.

Overview of Sections



Information on Conveyor Technology

1

Benefits of mk Conveyor Technology	6
Selecting a Conveyor Type	8
Selecting a Drive	12
QuickDesigner – The Conveyor Technology Configurator	16



Belt Conveyors

2

Selecting a Belt Conveyor	20
GUF-P MINI	22
GUF-P 2045	32
GUF-P 2000	36
GUF-P 2041	52
GUF-P 2004	62
KFG-P 2000	70
KGF-P 2040	80
DGF-P 2001	84
Belts	88
Cleats/Side Walls	92
Application Examples	96

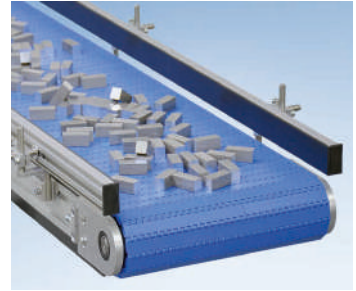

Modular Belt Conveyors

3

Selecting a Modular Belt Conveyor	118
MBF-P 2040	120
KFM-P 2040	124
KMF-P 2040	130
KFS-P 2040.86	136
Modular Belts	142
Application Examples	146



Timing Belt Conveyors

4

Selecting a Timing Belt Conveyor	154
ZRF-P 2040	156
ZRF-P 2010	160
Timing Belts	170
Accessories	172
Application Examples	176

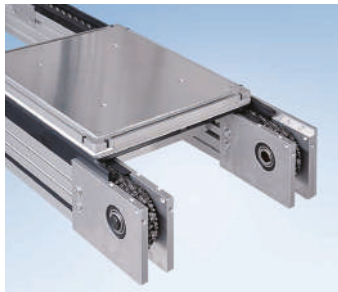

Chain Conveyors

5

Selecting a Chain Conveyor	184
KTF-P 2010	186
SRF-P 2010	196
SRF-P 2012	206
Chains	214
Accessories	216
Application Examples	220



Flat Top Chain Conveyors

6

SBF-P 2254	228
SBF-EMMA	236
Application Examples	238



Roller Conveyors

7

Selecting a Roller Conveyor	246
RBS-P 2065/2066	248
RBS-P 2255	252
RBT-P 2255	256
RBM-P 2255	260
Rollers	264
Application Examples	266



Rotary Tables

8

DTZ-P 2040	274
Application Examples	276



Conveyor Technology Accessories

9

Stands	280
Side Rails	294
Nuts	300
Electrical Components	302
Other Accessories	304
Application Examples	306

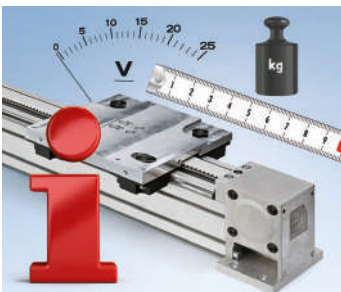

Information on Linear Technology

10

Benefits of mk Linear Technology	314
Selecting a Linear Guide	316

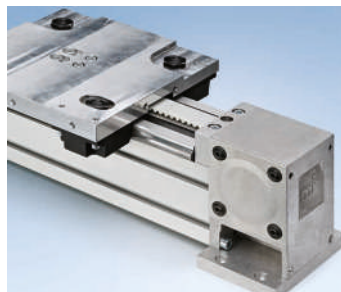

Linear Units and Modules

11

Gliding Assemblies	320
Track Roller Assemblies	332
Recirculating Ball Bearing Guides	384
Application Examples	392



Application Examples of System Solutions

12

Application Examples for Versamove	410
Application Examples for SPU 2040	414
Application Examples for TKU 2040	416
Application Examples for Handling Systems	418

Benefits of mk Conveyor Technology

1



» Function modules
for conveying
and handling. «

mk conveyor technology modules can meet virtually any requirement for the transport and handling of piece goods. You can select from a range of multi-industry, standardised and modular conveyor systems, which can also be customised if required. These systems can be combined with rotary tables for buffering product and linear technology modules for precise, dynamic handling tasks.

Conveyor Systems

mk offers the right conveyor system for virtually every transported product and all operating conditions. Simply enter your specific parameters into the product filter on our website to display the suitable system.

Rotary Tables

Rotary tables are ideal for maintaining continuous material flows. Workpieces can be buffered, stored, staggered or separated between work steps.

Linear Technology

mk linear technology is the name for our portfolio of gliding assemblies, track roller assemblies and recirculating ball bearing guides that provide highly precise and reliable linear motion, and that are designed to meet your specific requirements.

Accessories

To round off our conveyor technology, mk offers a wide selection of drives, different stand variants, various side rails, standardised and customised pallets, initiators, stoppers, control components and much more.

Benefits of mk Conveyor Technology

- A large selection of standardised, modular conveyor systems for optimal function with any transported product and in any environment
- Maximum process reliability thanks to sophisticated technology, high-quality materials and purchased parts, and rapid delivery of spare parts worldwide
- Built from standard modules to achieve cost savings and short delivery times
- Expertise in designing and constructing custom conveyors outside our standard product range
- Flexibility ensured by compatibility with all mk construction kit components and modules
- mk sales engineers provide expert advice and assistance in designing your system
- mk QuickDesigner online configurator with CAD model and quotations

Conveyor Systems



Rotary Tables



Linear Technology



Accessories



Selecting a Conveyor Type

1

Factors that Influence the Configuration of the Conveyor

The following factors influence the choice of conveyor to be used for your task and environmental conditions.

The product to be transported

- Weight of the individual product
- Total weight
- Shape of the contact surface
- Size
- Temperature
- Sensitivity to shock
- Dry vs. damp
- Oil content
- Sharp edges
- Other product-specific properties

The ambient conditions

- Temperature
- Contamination, for example, by dust or chemicals
- EX protection requirements
- Cleanroom conditions
- Food production areas
- Humidity

The transportation route

- Transport on straight lines or around curves
- Transport on one level or at different heights
- Output quantity and speed
- Specified or unspecified orientation/transfer/handling of the product

The operating mode

- Continuous operation or accumulated operation
- Cycling operation, on/off operation
- Stopping/positioning
- Reverse operation

Information Required for Inquiries and Orders

To ensure that the conveyor works in the optimum way for your requirements and environmental conditions, we require all the specifications for the influence factors specified above and a specification of the conveyor that is as detailed as possible.

Specification

	GUF-P 2000 AC /... /...
■ System designation	
■ Drive version	
■ Conveyor length L [mm]	
■ Conveyor width B [mm]	

- Drive location with motor orientation
- Tail (infeed end and discharge end)
- Belt type and any cleats or side walls
- Max. speed
- Speed mode (constant or controllable)
- Reglomat (if controllable speed is required)
- Stand version, including working height
- Side rail type
- Any other accessories

Drive packages

- 0 - without motor (drive AA or BA)
- 1 - with motor (drive AC-AU, BC, BF, CA)
- 2 - with motor and switch
- 3 - with motor and control of speed and direction
- 4 - with motor and small controller
- 5 - with motor and positioning controller

Make the process simple and use our QuickDesigner online configurator at www.quickdesigner.com or complete one of our request forms at www.mk-group.com/service. Our Technical Sales team is also happy to help you on site.

Ambient Conditions

When configuring a conveyor, we assume the usual ambient conditions in the production facility. That is, the application is indoors at room temperature (RT), in a clean environment with the usual humidity of < 60% and there is no condensation or dripping water.

Generally the range from +10° to +60° C is non-critical. In special cases (e.g. over longer lengths with a temperature differential greater than 50° C), the elongation of the installed components in length must be taken into account. Low temperatures down to -20° C are possible on request. Ambient temperatures above 80° C are only briefly permissible for most plastics. Ambient temperatures higher than 150° C are only permissible for aluminium base structures after testing. However, the temperatures for contact between the product and transport medium of up to 200° C are possible when using steel chains.

We are happy to provide consultation for applications in cleanrooms and sterile areas, applications with hygiene or pharmaceutical specifications, usage in harsh environmental conditions, potentially explosive atmospheres and painting applications.

Continuous Operation/Accumulated Operation

In continuous operation, the conveyor and the product run without interruption. The goods to be conveyed are supplied to the running conveyor and conveyed further. During accumulated operation, the conveyor continues to run below the accumulated, stationary product. Note that the motor power during accumulated operation must be approximately twice as high as it is in continuous operation (see diagram on page 12).

On/Off Operation

The conveyor is switched on and off as needed. This is usual for parts discharge or manual removal. We also always recommend on/off operation to reduce wear if it is foreseeable that no action will occur for more than 30s. For clean rooms especially, this is strongly recommended to avoid unnecessary contamination. If the conveyor is deactivated more than four times per minute, this is classified as cycling operation (startup with a load only with a soft start).

Cycling Operation

As a rule, the cycling operation is a fixed cycle that is repeated. If there are more than 30 cycles per minute, servo drives are usually required. Rates of more than 60 cycles per minute are available on request, but they require a detailed assessment of the application. The time available for transport and the required acceleration are important for the motor configuration. During acceleration, pay attention to the static friction of the product on the transport medium. See page 12 for additional information.

Positioning Operation

For positioning operation, the product is usually positioned with pinpoint precision in a controlled machining process, so that it then can be picked off, for example. For positioning operation, the specification of the accuracy to be achieved is important. Repeatability means that the product is repeatedly moved to the same point under the same conditions. Positioning accuracy is the absolute accuracy even with changing loads.

Positioning accuracy in a range of ± 10 mm is possible with simple devices, such as initiators or light barriers. As a rule, the range of ± 5 mm requires a positive-locking drive and control with signal transducers. The range of ± 1 mm represents the transition to the linear technology. This accuracy, including transverse to the conveying direction, requires the means of transport to be guided precisely and the position of the product to be fixed on the conveyor.

Selecting a Conveyor Type

1 Belt Conveyors

→ Page 18

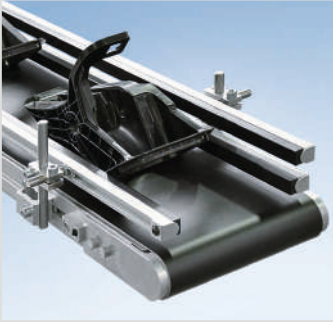

- For transporting piece goods without specific requirements regarding the product's position and orientation
- Closed belt surface for products with any product geometry
- Choose from a continuous range of different widths and lengths
- Belt runs quietly and with low wear, even at high speeds
- Large selection of belts for various products and applications, e.g. with product accumulation, suitable for food contact, antistatic, etc.
- Custom arrangement of transverse cleats and side walls

Widths [mm]	Lengths [mm]	Total load [kg]	Speed [m/min]	Double-line	Incline	Curves
50-2000	300-20000	up to 200 as standard	up to 80	yes	yes	yes

Modular Belt Conveyors

→ Page 116

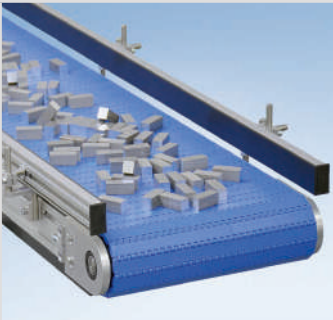

- For transporting piece goods without specific requirements regarding the product's position, orientation or the product geometry
- Positive drive mechanism eliminates slippage and makes it suitable for wet applications; permeable chains also available
- Various robust chain materials to accommodate high temperatures, contact with chemicals or food
- Stable chain travel regardless of the length/width ratio
- Products can be moved diagonally
- A variety of track layouts, including curves, are possible with just one drive

Widths [mm]	Lengths [mm]	Total load [kg]	Speed [m/min]	Double-line	Incline	Curves
200-1000	400-10000	up to 250 as standard	up to 30	—	yes	yes

Timing Belt Conveyors

→ Page 152



- Ideal for the cycled transport of pallets or products with a rigid structure
- Precise positioning via positive drive mechanism
- Selection of various timing belts with surface coatings customised for the specific application
- High speeds and accelerations possible with quiet and smooth operation
- Suitable pallets, lift-and-transfer modules, stoppers, positioning units, rotating units and control components available

Widths [mm]	Lengths [mm]	Total load [kg]	Speed [m/min]	Double-line	Incline	Curves
40-2000	500-6000	up to 250 as standard	up to 60	yes	—	—

Chain Conveyors

→ Page 182

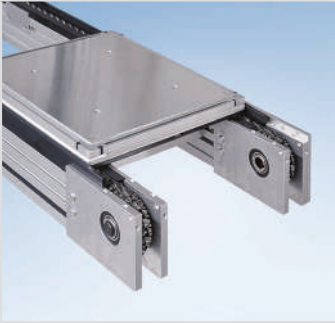

- Ideal as a dual or multiple line system for transporting pallets with heavy loads, including in accumulated operation
- Various chains and wear strips provide optimal support for the workpiece or pallet
- Suitable for dirty and oily environments
- Robust and temperature resistant
- Suitable pallets, lift-and-transfer modules, stoppers, positioning units, rotating units and control components available

Widths [mm]	Lengths [mm]	Total load [kg]	Speed [m/min]	Double-line	Incline	Curves
200-2000	500-10000	up to 1000 as standard	up to 30	yes	–	–

Flat Top Chain Conveyors

→ Page 226



- Typically used for transporting bottles, cans or small containers in feeding and interlinking applications
- Complex, three-dimensional track layouts can be constructed with a single conveyor, eliminating joints and transitions
- Positive drive mechanism eliminates slippage and makes it suitable for wet applications
- Various chains (including stainless steel) are available depending on the application, e.g. use in the food industry, etc.
- Suitable for position-based transport using pallets

Widths [mm]	Lengths [mm]	Total load [kg]	Speed [m/min]	Double-line	Incline	Curves
45-300	600-30000	up to 200 as standard	Up to 60	Yes	Yes	Yes

Roller Conveyors

→ Page 244



- Rollers mounted on ball bearings for high loads with low drive power
- For transporting piece goods such as solid boxes or pallets with rigid, flat bases
- Various drive concepts (gravity, tangential chain drive or drive rollers) available for different applications
- Friction rollers allow for accumulated operation
- You can employ segmentation to implement different speeds or start/stop functions in a single conveying path
- Sturdy, affordable and easy to extend

Widths [mm]	Lengths [mm]	Total load [kg]	Speed [m/min]	Double-line	Incline	Curves
150-1050	200-10000	up to 400 as standard	up to 70	–	–	yes

Selecting a Drive

1

Speed – continuous operation compared to cycling operation

The diagrams show the need for a higher maximum speed in cycling operation compared to continuous operation. In addition, they show an example of the course of a cycling operation with soft start-up and standstill for a different action (e.g. to process the conveyed product).

Continuous operation compared to cycling operation

Speed v [m/s]

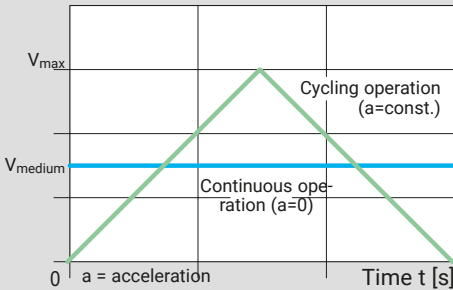

Example of cycling operation

Speed v [m/s]

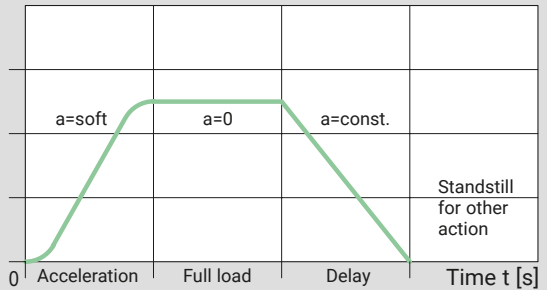

Selecting motors based on speed and load

This diagram can be used to determine the motor power required based on the total load (transported material + medium of transport) and the speed. The values shown correspond to a kinetic friction value of $\mu=0.3$, which is the friction between the belt and the underlying plate in a belt conveyor.

Total load m [kg]

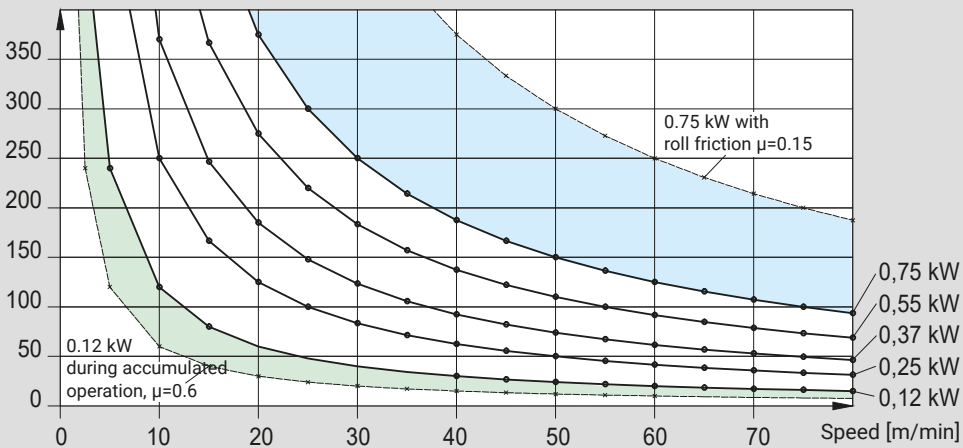

Example of the effect on the permissible total load and speed when the friction coefficient is halved from a belt conveyor ($\mu=0.3$) to a roller conveyor ($\mu=0.15$)

Example of the effect on the permissible total load and speed when the friction coefficient is doubled from continuous operation ($\mu=0.3$) to accumulated operation ($\mu=0.6$)

Drive Location

The **head drive** is located on the discharge end of the conveyor and pulls the transport medium, e.g. the belt. This is the most common, safest and most affordable drive position. If you have location restrictions, you can also install a head drive on the infeed end for use as a rear drive (pushing). In this case, however, you must provide adequate pre-tension and prevent the transport medium from getting kinked.

Lower belt drives, which are also called centre drives, can be installed in various locations below the transport level. The primary application for these drives is reverse operation (reversible conveying direction), since the transport medium is always pulled, preventing the problems that arise when the belt is pushed. You can achieve fixed installation lengths by selecting the design with a tensioning roller in the centre drive. Since two snub rollers are typically used, this drive is also known as an omega drive. A further benefit of this drive is the option to install knife edges on both the infeed and discharge ends for transferring small products.

Internal drives with a drum motor produce small obstructing edges, making them particularly popular for applications with limited installation space. They are also popular in clean environments, since they exhibit low particle emissions and have few surfaces on which dirt can deposit.

Drive Type

In the most commonly used **indirect drives**, force is transferred using a chain or timing belt. This additional option to adjust the transmission ratio allows you to achieve very fine speed increments and compensate for alignment errors. With servo and stepper motors, a timing belt can be used to dampen the abrupt, jerky starting behaviour.

With a **direct drive**, the motor is connected directly to the drive shaft, offering a compact and low-maintenance alternative.

Motor Selection

Our standard product range also includes a variety of different stock equipment motors from well-known manufacturers. These gearmotors, consisting of asynchronous AC motors as standard or DC motors, combined with a Spiroplan, helical-worm or helical gearbox, meet efficiency class II and IP 54. Custom motors, servomotors, UL-CSA approval and multi-range motors are also available as options.

Speeds

The maximum conveying speed depends on the motor selected, the load on the belt, the operating mode and other factors. The speeds provided here are nominal values and may deviate due to the speed tolerances of the motors (up to $\pm 10\%$). For indirect drives using chains or timing belts, the tolerance tends to be even higher, at up to 20% above the nominal speed. Higher speeds are also achieved when the system is operated on a 60 Hz grid, for example in the USA. If you need a precisely defined speed, this can be accomplished with an mk reglomat.

Adjustment Ranges







The mk reglomat lets you control the conveyor speed within a range of 1:7 (10–70 Hz), assuming an alternating current and the nominal speed at 50 Hz. For internal drives (drum motors), the adjustment range is 1:3 (20–60 Hz). With direct current, the range is 1:6 (0.25–1.5 A or 0.5–3 A).

Selecting a Drive

1

A – Head Drives

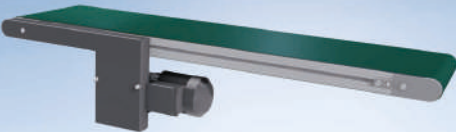

	<p>AA</p>	<p>Head drive without motor This drive version with an open drive journal can be connected to a conveyor with a motor for parallel operation</p>
	<p>AC</p>	<p>Standard head drive Drive version with a variety of combination options for motors, gearboxes and sprocket wheels</p>
	<p>AF</p>	<p>Direct head drive Compact and low-maintenance drive version with a motor that is fitted directly on the drive shaft</p>
	<p>AD AG</p>	<p>Head drive, compact Drive version with minimal interference contours thanks to small gear motor, available with direct current motor or three-phase motor</p>
	<p>AM</p>	<p>Head drive, offset Thanks to the variably configurable head drive, there are no interference contours at the discharge end of the conveyor</p>
	<p>AS</p>	<p>Head drive, laterally on the outside, compact A drive version restricted to a minimum total height with motor mounted on the outside</p>
	<p>AU</p>	<p>Head drive, laterally on the outside Since the motor is mounted laterally from the outside, the space underneath and above the conveyor remains free of interference contours</p>

B – Lower Belt Drives



1

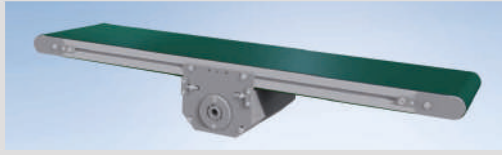

BA

Lower belt drive without motor

Drive unit variably mounted underneath the conveyor, enables connection on a conveyor with motor for parallel operation



BC

Lower belt drive, standard

Possibility of reverse operation and configuration of knife edges, at both the infeed end and discharge end



BF

Lower belt drive, direct

Compact and low-maintenance drive version with a motor that is fitted directly on the drive shaft

C – Internal Drives

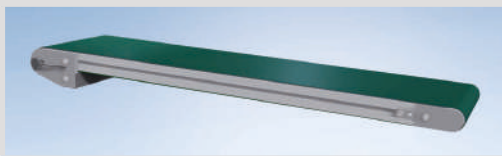

CA

Drum motor

Maintenance-free and compact drive version without exterior interference contour with a drive version as a driving roll

The drive versions are shown on the belt conveyor in the example

Drive Location

The drive location determines how and where the drive, including the motor, is installed. You can choose to position the drive on the infeed or discharge end, above or below the conveyor frame, on the left or on the right.

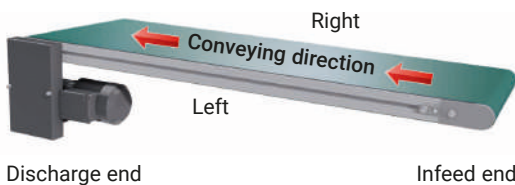

Motor Orientation

As shown in the figures, the motor orientation can vary between 0°, 90°, 180° and 270°. If the customer does not specify the drive location, the drive is delivered on the discharge end, on the left side, below the conveyor and with a motor orientation of 0°.

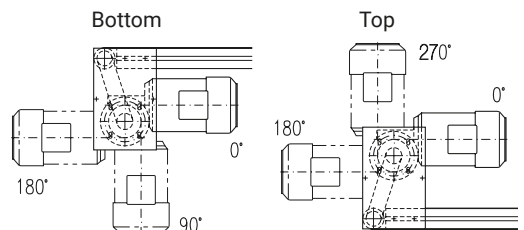

QuickDesigner – The Conveyor Technology Configurator

1



» Your conveyor at the push of a button. «

Our “QuickDesigner” online configurator lets you create a custom mk belt conveyor based on your exact requirements quickly and easily. You do not require any software; time-consuming installation is dispensed with.

Simply enter quickdesigner.com in your browser, click Start, and that’s it.

Your on-screen entries are checked for plausibility immediately, to ensure that you are always offered the optimal conveyor. All the entry fields have an info button with detailed instructions to make the tool as easy as possible to use.

When your desired conveyor is complete, you can immediately generate a CAD model and a quote. In “My Account”, you can also access and edit the configurations you create and their models and quotations at any time.

If you place an order, we have all the relevant data in the system, which makes the whole process, including the delivery, much quicker. Even if you require a special solution, we design it on the basis of the created standard model. A cost advantage for you.

Benefits of mk QuickDesigner

- Quick, simple and based on your specific requirements
- Available any time, anywhere (24/7)
- Can be used on a mobile device
- Live view during configuration
- CAD model and quotations
- Save configurations and edit them later
- In-depth support
- German/English

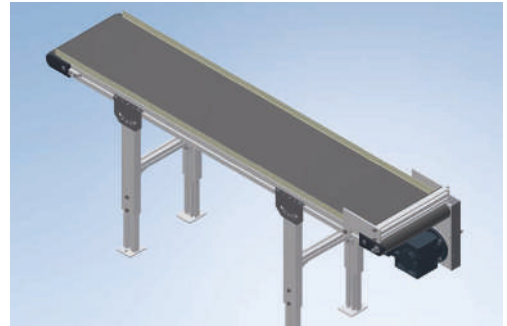
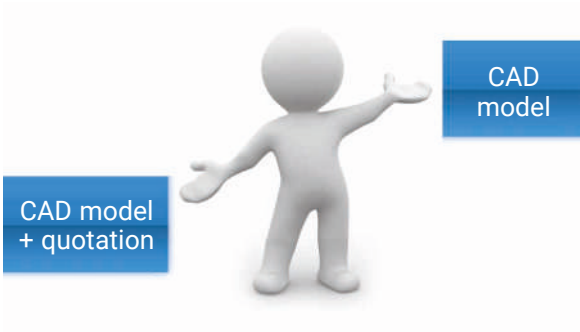
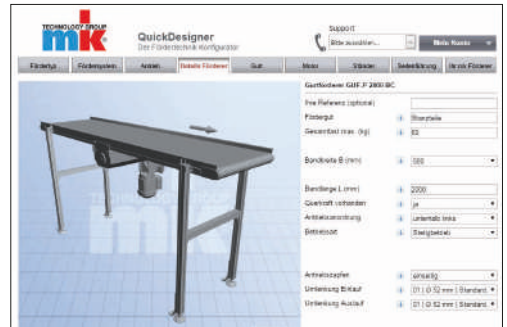

Chapter 2 Belt Conveyors

2



Selecting a Belt Conveyor

20

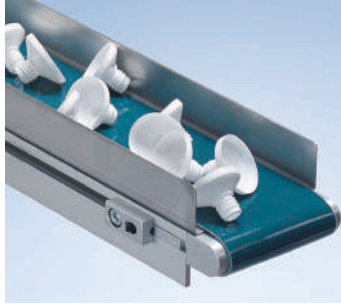

Belt Conveyor GUF-P MINI

- Head Drives
- Lower Belt Drives
- Tails

22

24
28
30

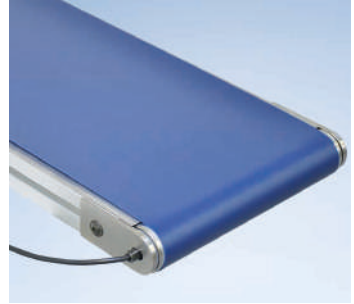

Belt Conveyor GUF-P 2045

- Internal Drive
- Tails

32

34
35



Belt Conveyor GUF-P 2000

36

- Head Drives
- Lower Belt Drives
- Internal Drives
- Tails

38
45
48
49



Belt Conveyor GUF-P 2041

- Head Drives
- Lower Belt Drives
- Internal Drives
- Tails

52

54
58
59
60



Belt Conveyor GUF-P 2004

- Head Drives
- Tails

62

64
68

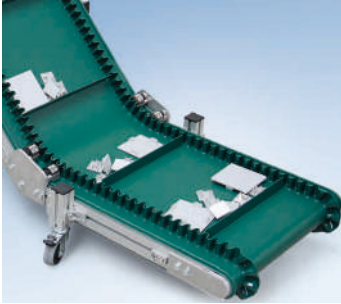

**Incline Conveyor Belt
KFG-P 2000** 70

Head Drives 72
 Variant ECO 76
 Stands 78
 Side Rail and Sample Order 79

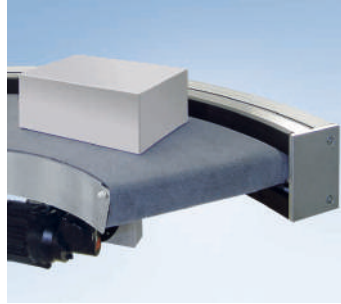

**Curved Belt Conveyor
KGF-P 2040** 80

Lower Belt Drives 82
 Stands and Order Specifications 83

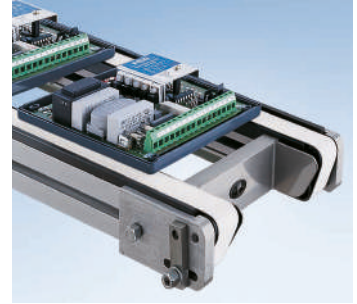

**Double Belt Conveyor
DGF-P 2001** 84

Head Drives 86
 Pallets 87

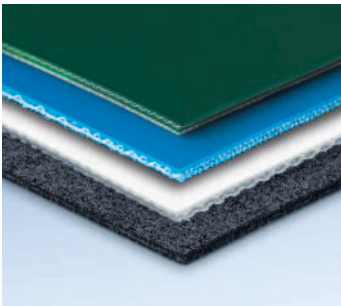

Belts 88



Cleats and Side Walls 92



Application Examples 96

Selecting a Belt Conveyor

2

Dimensions – Technical Data

Conveyor system	Conveyor widths [mm]	Conveyor lengths [mm]	Total load* as standard, up to [kg]	Speed up to [m/min]	ø of tails [mm]	Reverse operation	Accumulated operation	Cycling operation
Belt conveyors								
GUF-P MINI	75/100/150	360-5000	25	50	22/32	•	•	•
GUF-P 2045	275/300/350/400/500	600-2500	15	-	50	•	•	•
GUF-P 2000	50-800	380-10000	75	80	10/12/19/53	•	•	•
GUF-P 2041	200-1200	540-10000	150	60	22/85	•	•	•
GUF-P 2004	200-2000	720-20000	200	60	105		•	•
Incline conveyor belt								
KFG-P 2000	300-700	1400-4000	40	15	53			•
Curved belt conveyor								
KGF-P 2040	300-600	90°/180°	30	30	19	•		
Double belt conveyor								
DGF-P 2001	100-250	300-2000	15	15	25		•	•

*Maximum load that is transported by the system in question with a standard configuration and for a standard application. The permissible load depends on the width, roller diameter, belt type, pre-tension, load distribution, operating mode and environmental influences.

System Selection

... Based on Load and Conveyor Width

The diagram can be used as a basis for determining the permissible total load based on the conveyor width of each conveyor system. The values included apply to the max. tail diameter per system and a belt with a strength K1% of 5 to 8 N/mm.

Total load [kg]

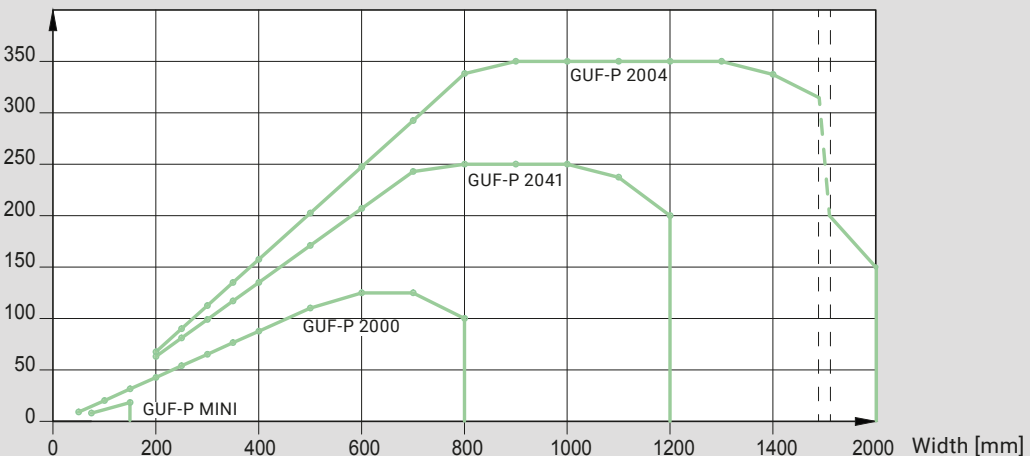

Conveyor Width

The conveyor width is the width of the conveyor frame without the tails. The belt is narrower to allow for self-adjusting tracking, between 10 and 50 mm depending on the system.

Conveyor Length

The conveyor length is a nominal dimension and is defined as the outer distance of the head parts when the system is not tensioned. The actual conveyor length is longer and is calculated based on the following aspects (specifications apply at an ambient temperature of 20°):

- Belt tensioning distance of approx. 0.3% of the conveyor length
- Belt length tolerance of up to 0.8% of the conveyor length
- Belt thickness tolerance of 1 to 5 mm per side
- Rollers protruding over the head parts by 1 to 3.5 mm per side

If a precisely defined installation length is strictly required, this can be accomplished using lower belt drives.

Length-Width Ratio

To ensure that the belt runs safely and stably, the conveyor must not fall below or exceed a specific length-width ratio (1:1 to 50:1).

A stable area without restrictions has a ratio of length to width from 2:1 to 20:1 (i.e. from twice as long as wide, to 20 times as long as wide).

Likewise, a range from 1.5:1 to 2:1 is also usually possible without restrictions, but requires a design test. The range of 1:1 to 1.5:1 can only be implemented with supplemental measures and restrictions.

In the range of 20:1 to 50:1, only laterally stiff belts must be used; in addition, transverse forces are no longer permissible. They occur, for example, when there is lateral movement, lateral product discharge, lateral product transfer, lateral product alignment using a side rail and asymmetric load distribution.

Speed

The maximum conveying speed depends on the motor selected, the load capacity, the operating mode and other factors.

With an indirect chain drive with a \varnothing 50 mm roller, a speed of up to 80 m/min is possible. The selection of a timing belt for force transmission is recommended for 30 m/min or higher, and is standard for 60 m/min or higher and cycling operation. Slim rollers are balanced for speeds of 60 m/min or higher, and dynamically balanced for 100 m/min or higher.

For high speeds, it is sensible to choose large driving rolls (e.g. for 80 m/min with the GUF-P 2000, a BC drive with a \varnothing 88 mm roller).

Adjustment Ranges

The mk reglomat lets you control the conveyor speed within a range of 1:7 (10–70 Hz), assuming an alternating current and the nominal speed at 50 Hz. For internal drives (drum motors), the adjustment range is 1:3 (20–60 Hz). With direct current, the range is 1:6 (0.25–1.5 A or 0.5–3 A).

Belt Conveyor GUF-P MINI



» Transport and separate small products with low volume and weight. «

The low installation height and the lower side walls for placing the conveyor directly onto the machine bed are ideal for the direct discharge of light and small products (from an injection moulding machine, for instance). The small tail diameters prevent large gaps during product transfer. The profile design ensures a torsion-resistant structure with good load-bearing properties. The values for the total load, speeds, and so on, specified below are directly related to this design and may vary as a result.

The driving rolls of the various drive versions can be rubberised to suit the application, so that motor torque can be optimally transmitted. Crowned driving and idler rollers simplify belt adjustment and help the belt to run in the centre of the conveyor frame. A stainless steel sheet is mounted under the running surface of the belt to ensure sustained wear resistance. The conveyor frame keys ensure that the belt returns within the conveyor frame.

Benefits of the GUF-P MINI

- Transport and separate small products with low volume and weight
- Very low installation height for easy integration into complex systems
- Belt recirculation integrated into the conveyor frame to permit placement directly on the machine bed
- Very small tail diameters keep gaps at product transfer points narrow
- Wide variety of drive units and belt designs to suit any application
- Profile design provides a torsion-resistant structure and good load-bearing properties
- Flexible operation in reverse, accumulated and cycling mode

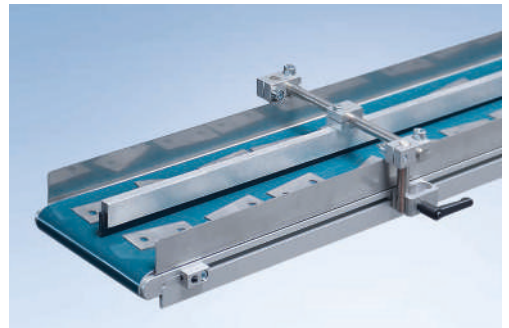
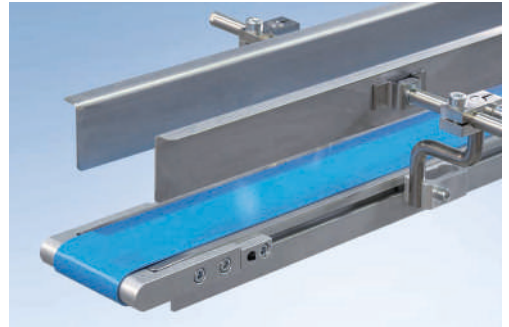

Cross Section

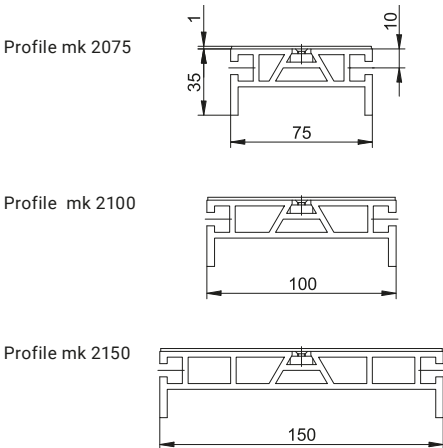

Properties

The drive version AA without a motor offers the advantage of operating multiple conveyor belts in parallel or in series with one drive. The compact conveyor frame design makes it easier to integrate the conveyor into existing systems. The $\varnothing 53$ mm driving roll combined with the snub roller ensures excellent transmission of the motor power. Operation with cleated belts is not possible with this version. The $\varnothing 16$ mm shaft journal and usable length of 19 mm is designed with a DIN 6885 key (5 x 5 x 16 mm).

B20.75.009

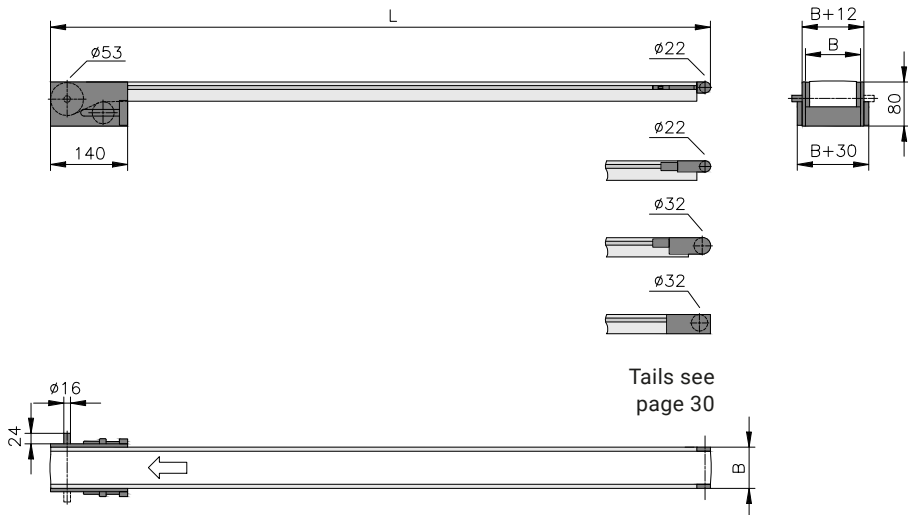

Technical data

Conveyor length L	individual from 360 to 5000 mm	
Conveyor width B	75 mm, 100 mm and 150 mm	
Belt width	B-15 mm	from p. 88
Drive and speed	up to $v=60$ m/min	p. 12
Stand and side rail		from p. 280
Standard total load	up to 25 kg	p. 20
Standard distributed load	up to 10 kg/m	p. 20



Properties

The compact conveyor frame design with the most popular drive variants makes it easier to integrate the conveyor into existing systems. The $\varnothing 53$ mm driving roll combined with the snub roller ensures excellent transmission of the motor power. Operation with cleated belts is not possible with this version.

B20.75.001

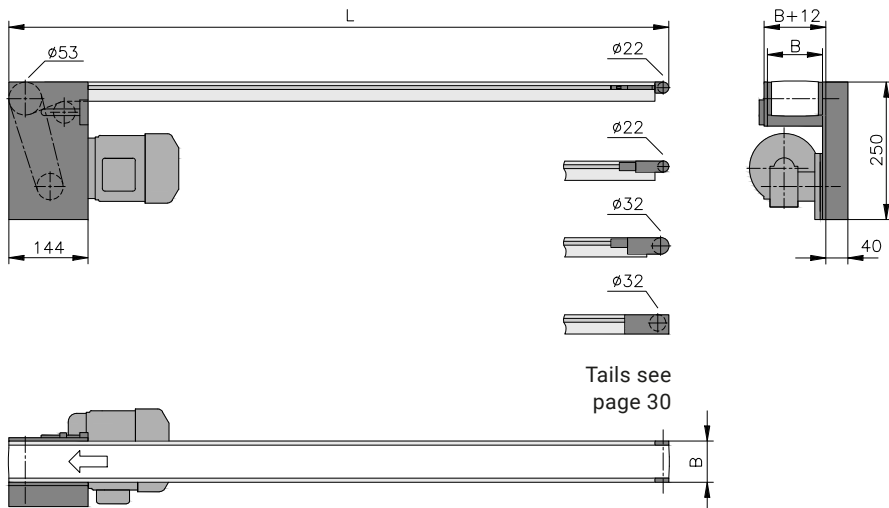

Technical data

Conveyor length L	individual from 360 to 5000 mm	
Conveyor width B	75 mm, 100 mm and 150 mm	
Belt width	B-15 mm	from p. 88
Drive location	discharge end left/right, underneath; infeed end on request	
Drive and speed	up to $v=60$ m/min	p. 12
Stand and side rail		from p. 280
Standard total load	up to 25 kg	p. 20
Standard distributed load	up to 10 kg/m	

Properties

2

The compact conveyor frame design and drive makes it easier to integrate the conveyor into existing systems. Without a snub roller, the $\varnothing 32$ mm driving roll enables the use of cleated belts. In comparison to the drive version AC, the drive is once again much more compact.

B20.75.033

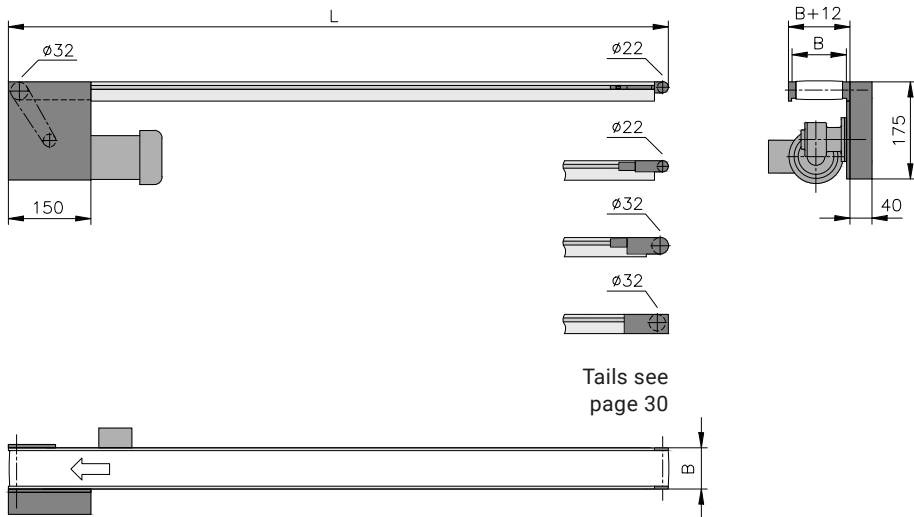

Technical data

Conveyor length L	individual from 370 to 5000 mm	
Conveyor width B	75 mm, 100 mm and 150 mm	
Belt width	B-15 mm	from p. 88
Drive location	discharge end left/right, underneath; infeed end on request	
Drive and speed	up to $v=15$ m/min	p. 12
Stand and side rail		from p. 280
Standard total load	up to 15 kg	p. 20
Standard distributed load	up to 10 kg/m	p. 20



Properties

For the compact drive version AG, mk offers a multitude of drive motors (direct current or three-phase motors) tailored to various speed and load capacity requirements. The compact conveyor frame design makes it easier to integrate the conveyor into existing systems. Without a snub roller, the $\phi 32$ mm driving roll enables the use of cleated belts. In comparison to the drive version AC, the drive is once again much more compact.

B20.75.004

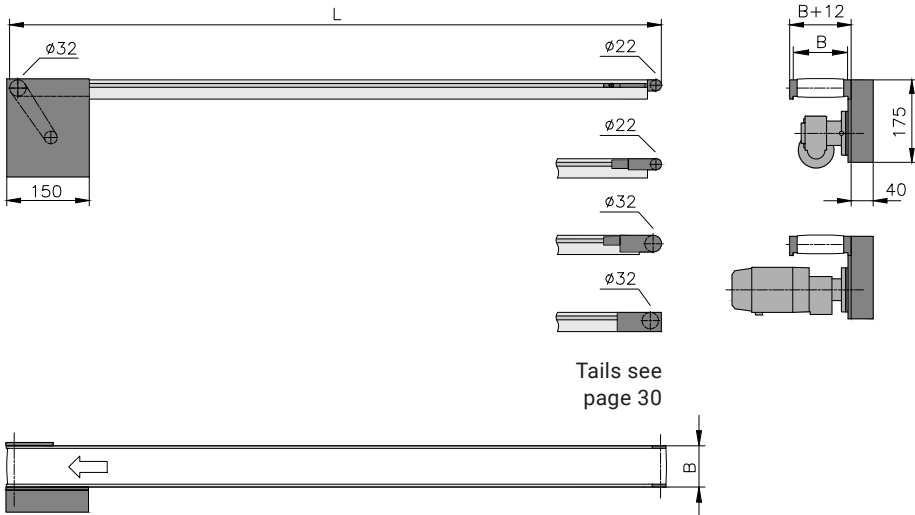

Tails see page 30

Technical data

Conveyor length L	individual from 370 to 5000 mm	
Conveyor width B	75 mm, 100 mm and 150 mm	
Belt width	B-15 mm	from p. 88
Drive location	discharge end left/right, underneath; infeed end on request	
Drive and speed	up to $v=15$ m/min	p. 12
Stand and side rail		from p. 280
Standard total load	up to 15 kg	p. 20
Standard distributed load	up to 10 kg/m	p. 20

Properties

The drive variant BA without a motor provides the advantage of operating multiple conveyor belts in parallel with one drive. The compact conveyor frame design and the ability to freely select the drive position over the entire length of the conveyor make it easier to integrate the drive into existing systems. The conveying direction is reversible. Operation with cleated belts is not possible with this version. The driving roll has a hollow shaft design with $\varnothing 20$ mm with keyway in accordance with DIN 6885.

B20.75.030

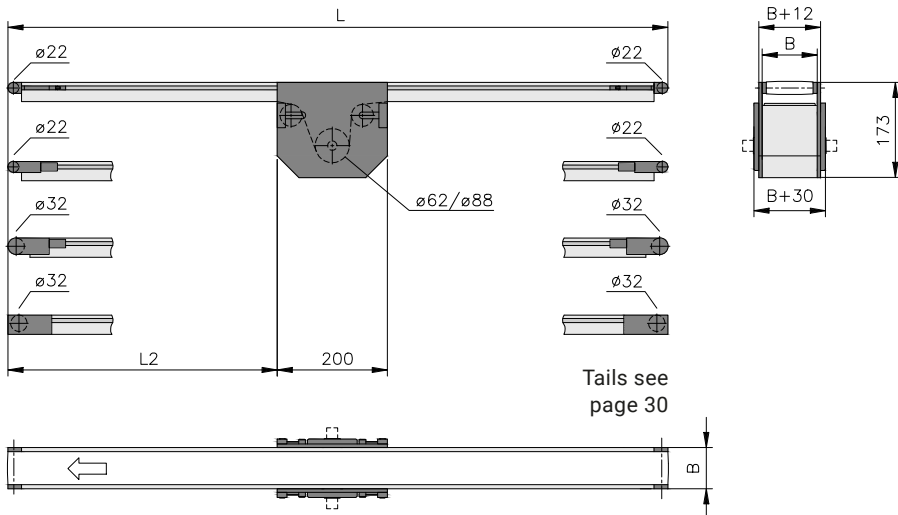

Technical data

Conveyor length L	individual from 550 to 5000 mm	
Conveyor width B	75 mm, 100 mm and 150 mm	
Belt width	B-15 mm	from p. 88
Drive and speed	up to $v=60$ m/min	p. 12
Stand and side rail		from p. 280
Standard total load	up to 25 kg	p. 20
Standard distributed load	up to 10 kg/m	p. 20



Properties

For the drive version BC, mk offers a multitude of drive motors tailored to various speed and load capacity requirements. The compact conveyor frame design and the ability to freely select the drive position over the entire length of the conveyor make it easier to integrate the conveyor into existing systems. The conveying direction is reversible. Operation with cleated belts is not possible with this version.

B20.75.005

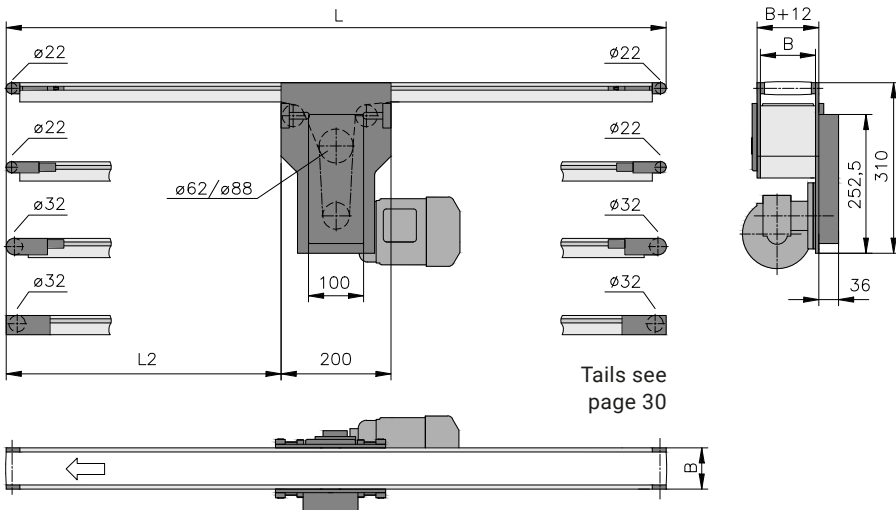

Technical data

Conveyor length L	individual from 550 to 5000 mm	
Conveyor width B	75 mm, 100 mm and 150 mm	
Belt width	B-15 mm	from p. 88
Drive location	left/right underneath	
Drive and speed	up to $v=60$ m/min	p. 12
Stand and side rail		from p. 280
Standard total load	up to 25 kg	p. 20
Standard distributed load	up to 10 kg/m	p. 20

GUF-P MINI Tails

2

Tail 01

Item no. B80.01.006

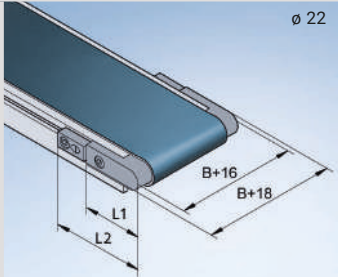

- Crowned roller, \varnothing 22 mm
- Ball bearing 2RS1
- Belt tensioning and adjustment on the side using the tensioning elements
- Min. length of the conveyed product for transfer of 54 mm
- Note the min. bend radius for the desired belt

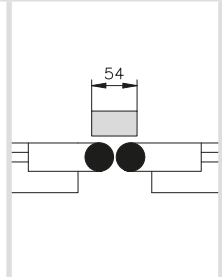

Conveyor length L	Conveyor width B	L1	L2	Head part material
$\leq 2,000$ mm	≤ 150 mm	60 mm	90 mm	Aluminium
$> 2,000$ mm	≤ 150 mm	100 mm	130 mm	Aluminium

Tail 03

Item no. B80.01.001

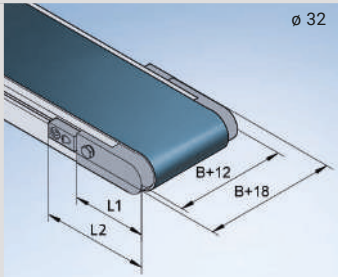

- Crowned roller, \varnothing 32 mm
- Ball bearing 2RS1
- Belt tensioning and adjustment on the side using the tensioning elements
- Min. length of the conveyed product for transfer of 74 mm
- Note the min. bend radius for the desired belt
- Optional laterally flush \varnothing 32 tail also available

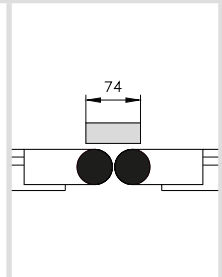

Conveyor length L	Conveyor width B	L1	L2	Head part material
$\leq 2,000$ mm	≤ 150 mm	75 mm	105 mm	Aluminium
$> 2,000$ mm	≤ 150 mm	115 mm	145 mm	Aluminium

Tail 11

Item no. B80.01.007

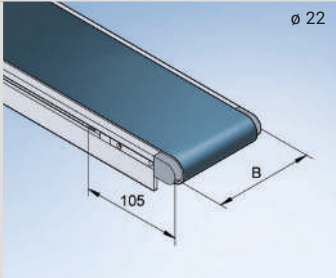

- Crowned roller, \varnothing 22 mm
- Ball bearing 2RS1
- Belt tensioning and adjustment on the side using the tensioning elements (approx. 25 mm of clearance required on each side)
- Min. length of the conveyed product for transfer of 54 mm
- Note the min. bend radius for the desired belt
- Flush head parts

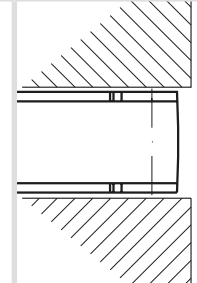

Conveyor length L	Conveyor width B	L1	L2	Head part material
$\leq 5,000$ mm	≤ 150 mm	105 mm	–	Aluminium

Tail 19

Item no. B80.01.004

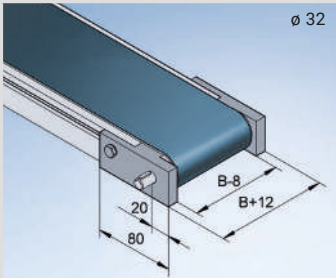

- Crowned roller, \varnothing 32 mm
- Ball bearing 2RS1
- \varnothing 10 mm shaft journal, length of 15 mm, keyway in accordance with DIN 6885
- Connection of two conveying lines through one drive (right, left or on both sides)
- Min. length of the conveyed product for transfer of 74 mm
- Note the min. bend radius for the desired belt
- Protruding head part (conveyor length L+5 mm)

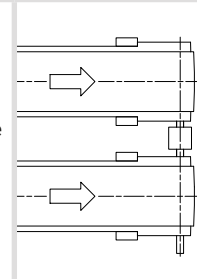

Conveyor length L	Conveyor width B	L1	L2	Head part material
$\leq 2,000$ mm	≤ 150 mm	80 mm	–	Aluminium

Belt Conveyor GUF-P 2045

2



»» For optimal integration in systems with limited installation space. ««

The extremely compact GUF-P 2045 belt conveyor is ideally suited for integration into systems with limited installation space. The \varnothing 50 mm drive roller combined with the weight-optimised, 45 mm tall conveyor frame profile produces a conveyor that is extremely flat and without any obstructing edges. The permitted total load of 15 kg is suitable for the majority of products typically found in the packaging and plastics industries. The speed is configured using the associated control board, which is designed for connection to an on-site voltage supply (DC 24 V).

Four different belts are available, with each offering either accumulation of the products or high grip. Stands, side rails, reglomats and transverse cleats are also available as accessories. The drive roller, the slide bed and the idler roller are also available in an optional stainless steel design.

Benefits of the GUF-P 2045

- Simple and affordable solution for the packaging and plastics industries
- Drum motor for extremely flat conveyor frames without obstructing edges
- For optimal integration in systems with limited installation space
- Control board for speed configuration
- Flexible operation in reverse, accumulated and cycling mode

Cross Section

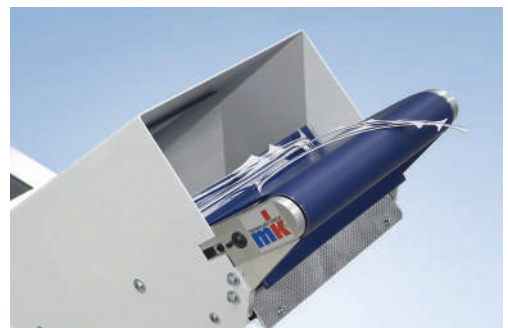
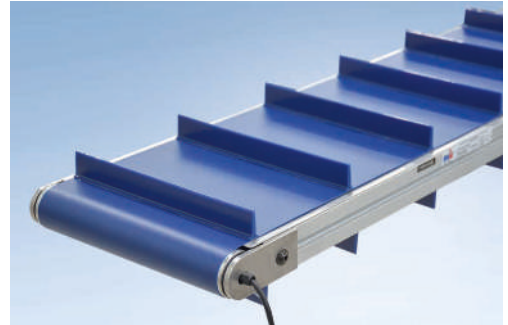
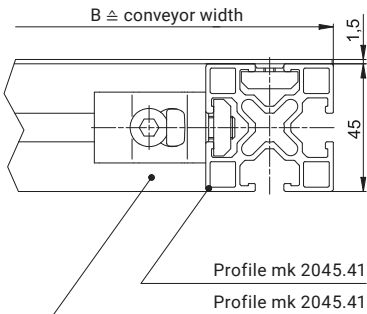

Properties

Since the motor is integrated into the driving roll, no obstructing edges protrude over the conveyor frame structure. The conveyor can therefore easily be integrated into existing systems. Operation with cleated belts is possible with this version.

B20.45.001

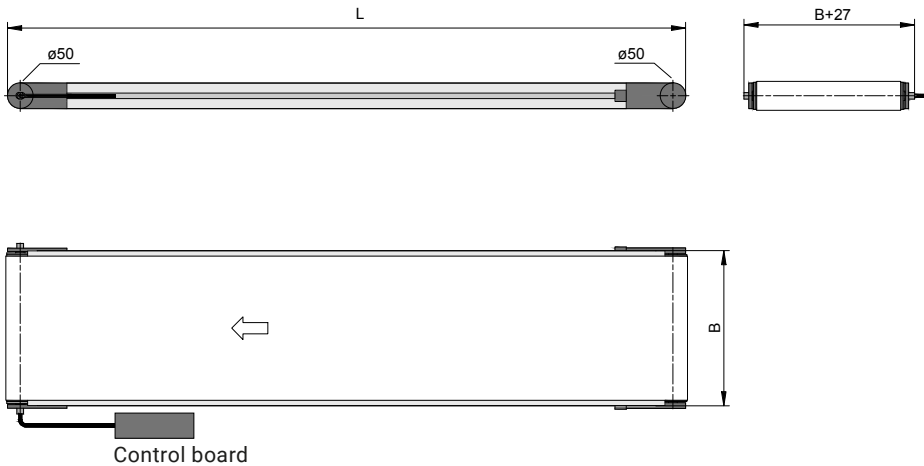

Technical data

Conveyor length L	individual from 600 to 2500 mm	
Conveyor width B	275, 300, 350, 400 and 500 mm	length-width ratio at least 2:1
Belt width	B-20 mm	
Belt types	GU-U0302-001WE	good traction, white, FDA
	GU-V0203-006DG	limited accumulation capability, green
	GU-U0202-053LB	limited accumulation capability, blue, FDA
	GU-U0303-054LB	good traction, blue, FDA
Speed [m/min]	3.7 4.9 6.1 7.3 8.6 9.8 11 12.2 13.4 14.6 15.9 17 18.3 19.5 22 23.1 24.4 25.4	can be configured using the supplied control board (IP20, higher on request) cable length 1 m (1.5 m available as an option)
Standard total load	up to 15 kg, accumulated operation: max. 5 kg, cycling operation: max. 10 kg	
Cycling operation	max. 900 cycles/hour	Minimum times: 2 s ON/2 s OFF

GU-F-P 2045 Tails

Tail 01

Item no. **B80.45.001**

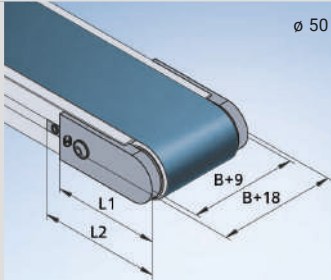

- Crowned roller, \varnothing 53 mm
- Ball bearing 2RS1
- Belt tensioning and adjustment on the side using the tensioning elements
- Min. length of the conveyed product for transfer of 114 mm

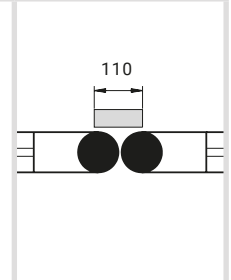

2

Conveyor length L	Conveyor width B	L1	L2	Head part material
≤ 2,500 mm	≤ 500 mm	105 mm	125 mm	Aluminium

Belt Conveyor GUF-P 2000



» The all-rounder
with the maximum
number of variants. «

The combination of standard parts based on the profile mk 2000 results in a conveyor system that allows for the widest possible range of drives and tails and extremely short delivery times. Despite its low height of 50 mm and the \varnothing 53 mm driving roll, which can be coated with rubber according to the application, the conveyor offers a wide range of different belt types. As with all mk belt conveyor systems, the round design of the driving and idler rollers make belt adjustment significantly easier.

System slots running along both sides (10 mm slot width based on our profile technology) allow you to easily integrate the conveyors into existing machine frames or attach stands, side rails and other accessories. A further quality feature of this conveyor system is the stainless steel sheet installed below where the belt runs, which ensures long-term wear resistance of the belt. In addition to our wide selection of side rails and stands, we also offer a standard range of end stops and electrical accessories.

Benefits of the GUF-P 2000

- Wide range of different drives, tails, stands and belt types
- Built with the profile mk 2000 for a high load capacity and torsion-resistant structure
- Optionally available with a stationary or rolling knife edge
- Flexible operation in reverse, accumulated and cycling mode
- Very short delivery times

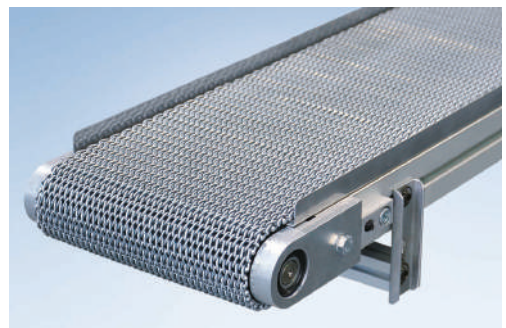
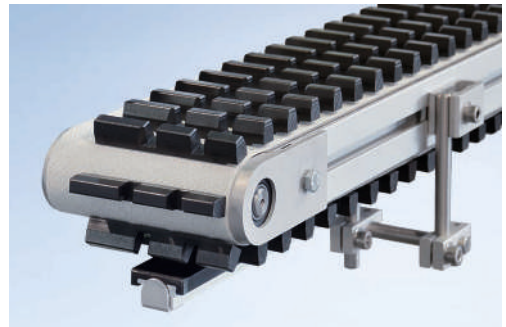
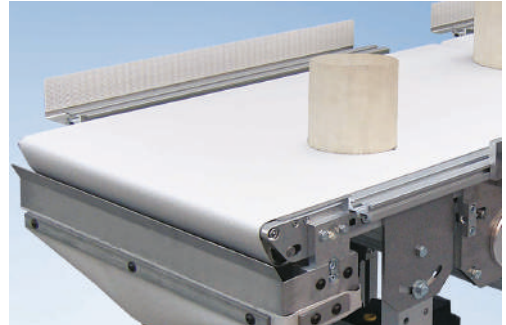

Cross Section

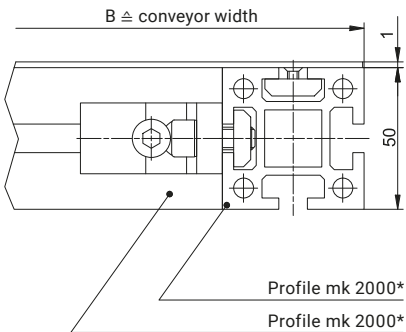

* For conveyor widths 75, 100, 150, 200 and 250 mm, custom profiles are used

Properties

2

The drive variant AA without a motor offers the advantage of operating multiple conveyor belts in parallel or in series with one drive. The compact conveyor frame design makes it easier to integrate the conveyor into existing systems. The driving roll $\varnothing 53$ mm has a round design for simple belt control. Operation with cleated belts is possible with this version. The $\varnothing 16$ mm shaft journal has a usable length of 20 mm with a chain drive or 29 mm with a timing belt drive and is equipped with a DIN 6885 key.

B20.00.009

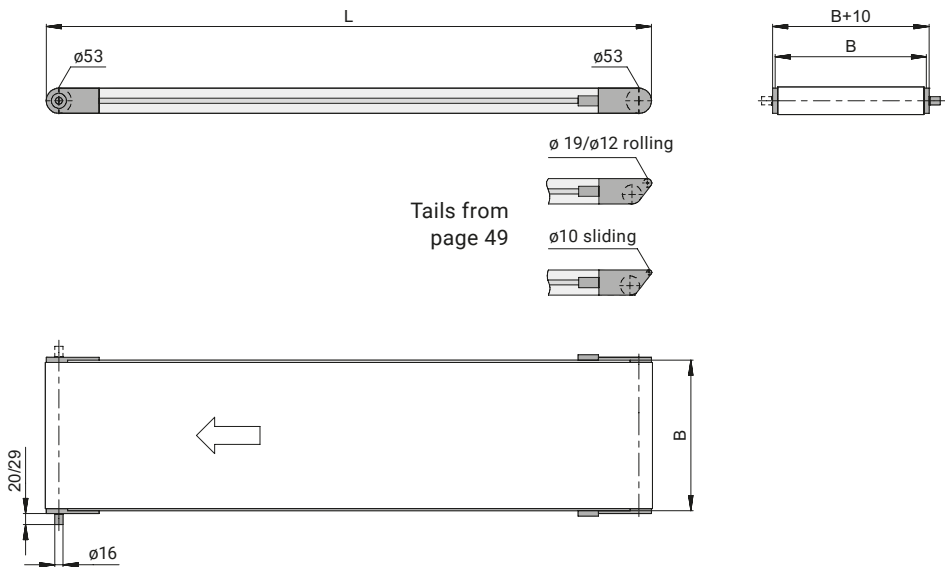

Technical data

Conveyor length L	individual from 380 to 10000 mm	
Conveyor width B	50, 75, 100, 150, 200, 250, 300, 400, 500, 600, 700, 800 mm	others on request
Belt width	B-10 mm	from p. 88
Drive and speed	up to $v=80$ m/min	p. 12
Stand and side rail		from p. 280
Standard total load	up to 75 kg	p. 20
Standard distributed load	up to 25 kg/m	p. 20



Properties

The compact conveyor frame design with the most popular drive variants makes it easier to integrate the conveyor into existing systems. The $\varnothing 53$ mm driving roller ensures excellent transmission of the motor power. Operation with cleated belts is possible with this version.

B20.00.002

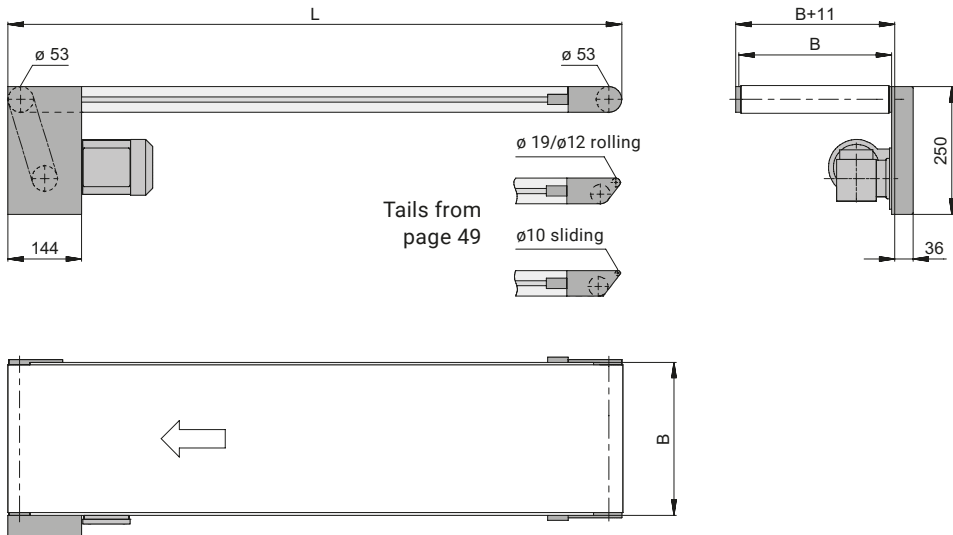

Technical data

Conveyor length L	individual from 410 to 10000 mm	
Conveyor width B	50, 75, 100, 150, 200, 250, 300, 400, 500, 600, 700, 800 mm	others on request
Belt width	B-10 mm	from p. 88
Drive location	discharge end left/right, underneath/above; infeed end on request	
Drive and speed	up to $v=80$ m/min	p. 12
Stand and side rail		from p. 280
Standard total load	up to 75 kg	p. 20
Standard distributed load	up to 25 kg/m	p. 20

Properties

2

Since the motor is fitted directly onto the drive shaft, the space requirements and maintenance effort for this drive version are reduced to a minimum.

B20.00.011

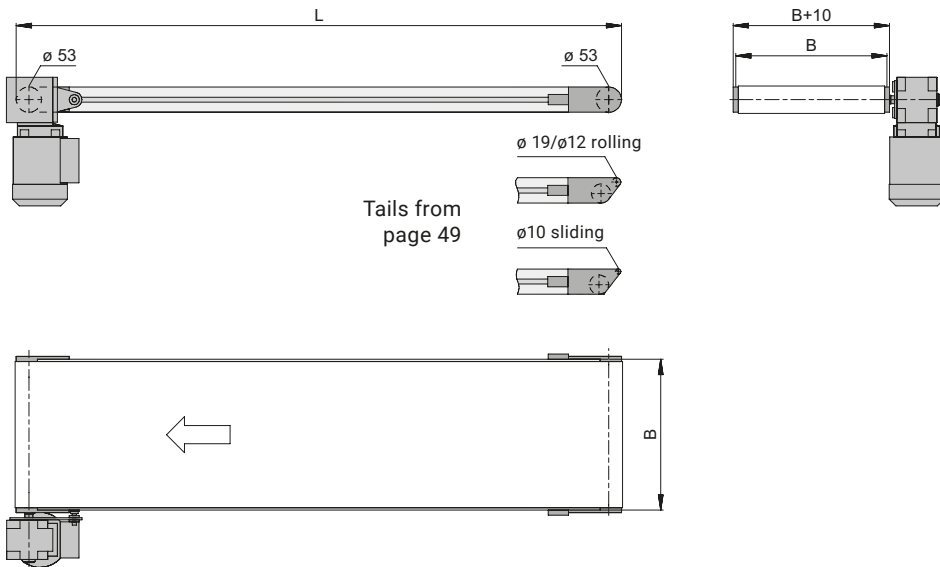

Technical data

Conveyor length L	individual from 410 to 10000 mm	
Conveyor width B	50, 75, 100, 150, 200, 250, 300, 400, 500, 600, 700, 800 mm	others on request
Belt width	B-10 mm	from p. 88
Drive location	discharge end left/right; infeed end on request	
Drive and speed	2.8; 3.7; 4.5; 5.5; 6.7; 7.9; 8.9; 11.2; 13.2 and 15.2 m/min	p. 12
Stand and side rail		from p. 280
Standard total load	up to 30 kg	p. 20
Standard distributed load	up to 25 kg/m	p. 20



Properties

The compact drive version AG for small gearmotors (direct current or three-phase motors) has fewer interfering edges in comparison to the AC drive version thanks to the gearbox type used. The compact conveyor frame design makes it easier to integrate the conveyor into existing systems. Without a snub roller, the $\varnothing 53$ mm driving roller enables the use of cleated belts. In comparison to the drive version AC, the dimensions of the drive are much more compact.

B20.00.005

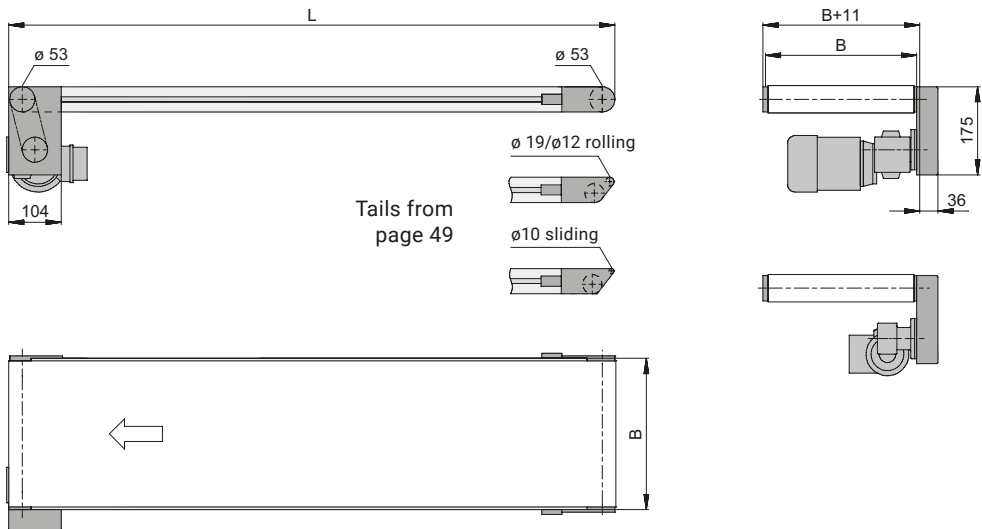

Technical data

Conveyor length L	individual from 380 to 6000 mm	
Conveyor width B	50, 75, 100, 150, 200, 250, 300, 400, 500, 600, 700, 800 mm	others on request
Belt width	B-10 mm	from p. 88
Drive location	discharge end left/right, underneath/above	
Drive and speed	up to $v=15$ m/min	p. 12
Stand and side rail		from p. 280
Standard total load	up to 30 kg AC/15 kg DC	p. 20
Standard distributed load	up to 25 kg/m	p. 20

Properties

2

The compact conveyor frame design with the offset head drive makes it easier to integrate the conveyor into existing systems. The $\varnothing 53$ mm driving roller ensures excellent transmission of the motor power. Operation with cleated belts is possible with this version.

B20.00.003

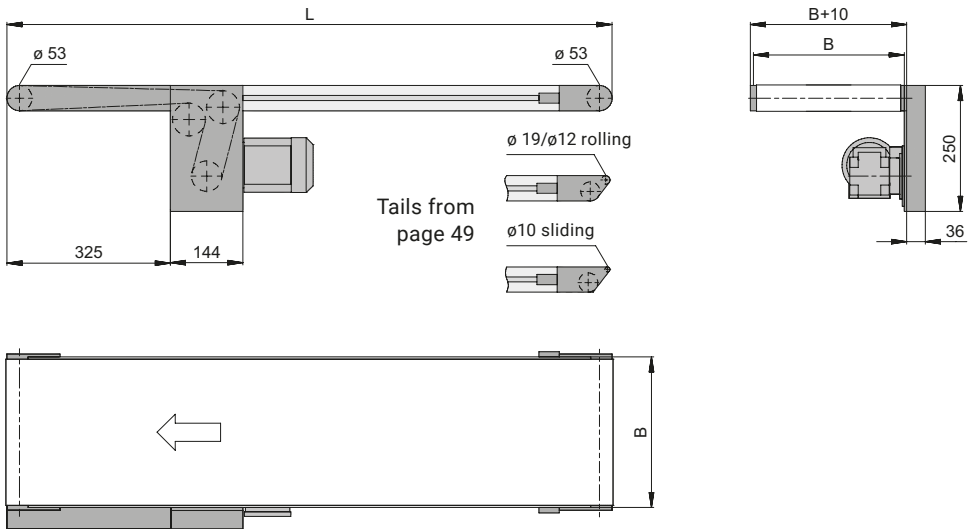

Technical data

Conveyor length L	individual from 750 to 10000 mm	
Conveyor width B	50, 75, 100, 150, 200, 250, 300, 400, 500, 600, 700, 800 mm	others on request
Belt width	B-10 mm	from p. 88
Drive location	discharge end left/right, underneath; infeed end on request	
Drive and speed	up to $v=80$ m/min	p. 12
Stand and side rail		from p. 280
Standard total load	up to 75 kg	p. 20
Standard distributed load	up to 25 kg/m	p. 20



Properties

The drive located laterally on the outside allows the total height of the conveyor to be restricted to a minimum. The $\varnothing 53$ mm driving roller ensures excellent transmission of the motor power. Operation with cleated belts is possible with this version.

B20.00.008

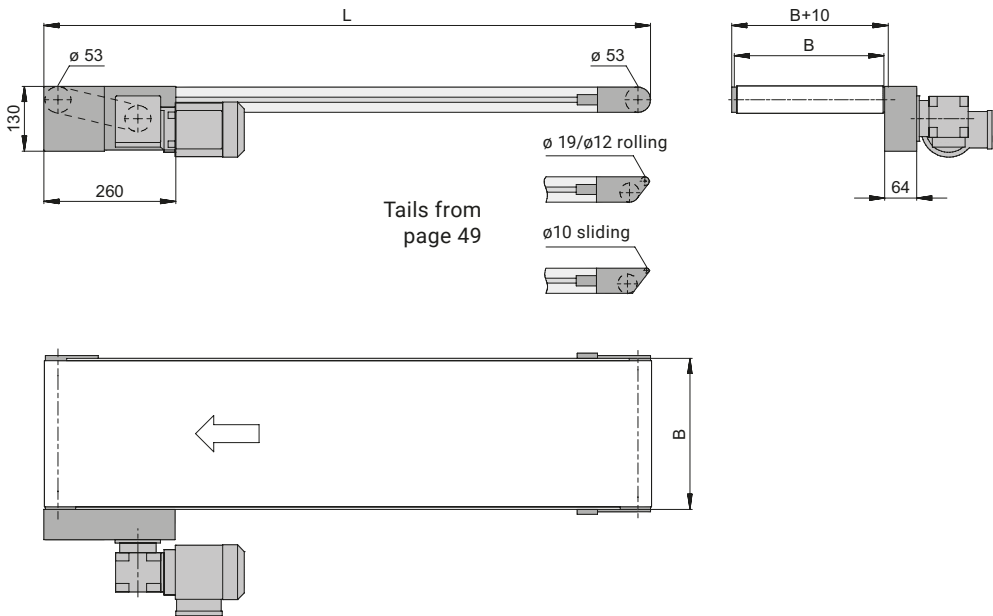

Tails from
page 49

Technical data

Conveyor length L	individual from 550 to 10000 mm	
Conveyor width B	50, 75, 100, 150, 200, 250, 300, 400, 500, 600, 700, 800 mm	others on request
Belt width	B-10 mm	from p. 88
Drive location	discharge end left/right; infeed end on request	
Drive and speed	up to $v=80$ m/min	p. 12
Stand and side rail		from p. 280
Standard total load	up to 75 kg	p. 20
Standard distributed load	up to 25 kg/m	p. 20

Properties

2

The advantage of the drive version AU is that the motor is fitted on the outside of the conveyor belt, which protects it from dirt. The space requirements for the conveyor in the lower run are much smaller in comparison. This drive version can transport even very tall products with ease. The $\varnothing 53$ mm driving roller ensures excellent transmission of the motor power. Operation with cleated belts is possible with this version.

B20.00.020

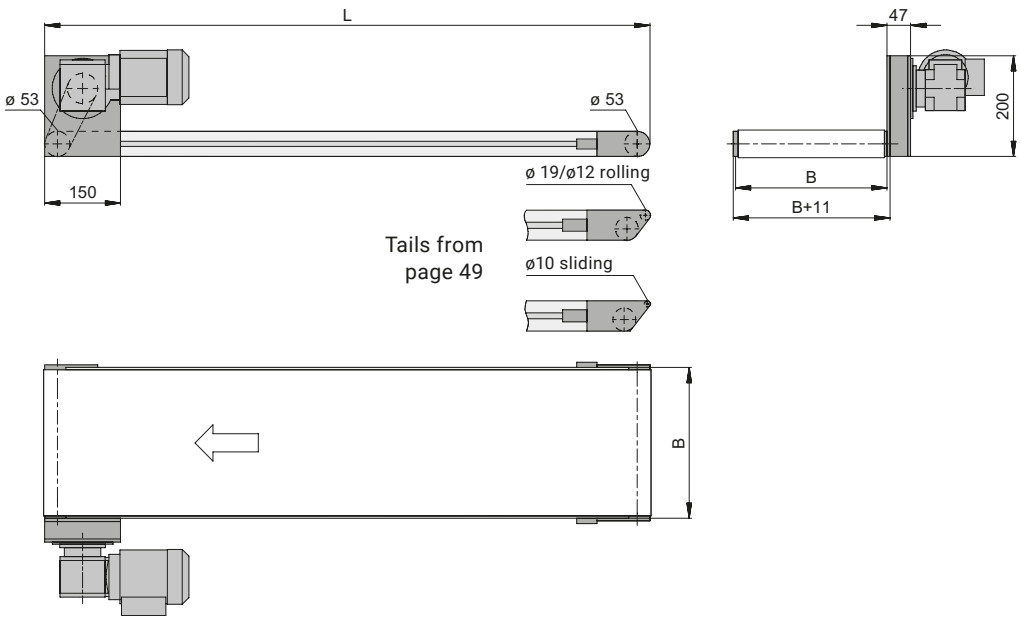

Technical data

Conveyor length L	individual from 430 to 10000 mm	
Conveyor width B	50, 75, 100, 150, 200, 250, 300, 400, 500, 600, 700, 800 mm	others on request
Belt width	B-10 mm	from p. 88
Drive location	discharge end left/right, underneath/above; infeed end on request	
Drive and speed	up to $v=80$ m/min	p. 12
Stand and side rail		from p. 280
Standard total load	up to 75 kg	p. 20
Standard distributed load	up to 25 kg/m	p. 20



Properties

The drive variant BA without a motor provides the advantage of operating multiple conveyor belts in parallel with one drive. The compact conveyor frame design and the ability to freely select the drive position over the entire length of the conveyor make it easier to integrate the conveyor into existing systems. The conveying direction is reversible. Knife edges can be configured on both the infeed and discharge end. Operation with cleated belts is not possible with this version. The driving roller has a hollow shaft design with $\varnothing 20$ mm with keyway in accordance with DIN 6885.

B20.00.001

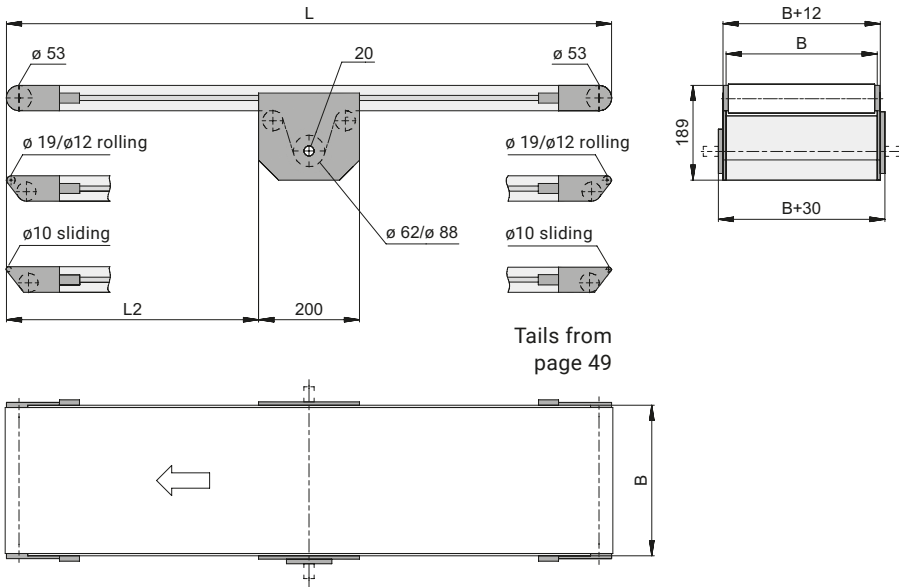

Technical data

Conveyor length L	individual from 700 to 10000 mm	
Conveyor width B	50, 75, 100, 150, 200, 250, 300, 400, 500, 600, 700, 800 mm	others on request
Belt width	B-10 mm	from p. 88
Drive and speed	up to $v=80$ m/min	p. 12
Stand and side rail		from p. 280
Standard total load	up to 75 kg	p. 20
Standard distributed load	up to 25 kg/m	p. 20

Properties

The compact conveyor frame design and the ability to freely select the drive position over the entire length of the conveyor make it easier to integrate the conveyor into existing systems. The conveying direction is reversible. Knife edges can be configured on both the infeed and discharge end. Operation with cleated belts is not possible with this version.

B20.00.004

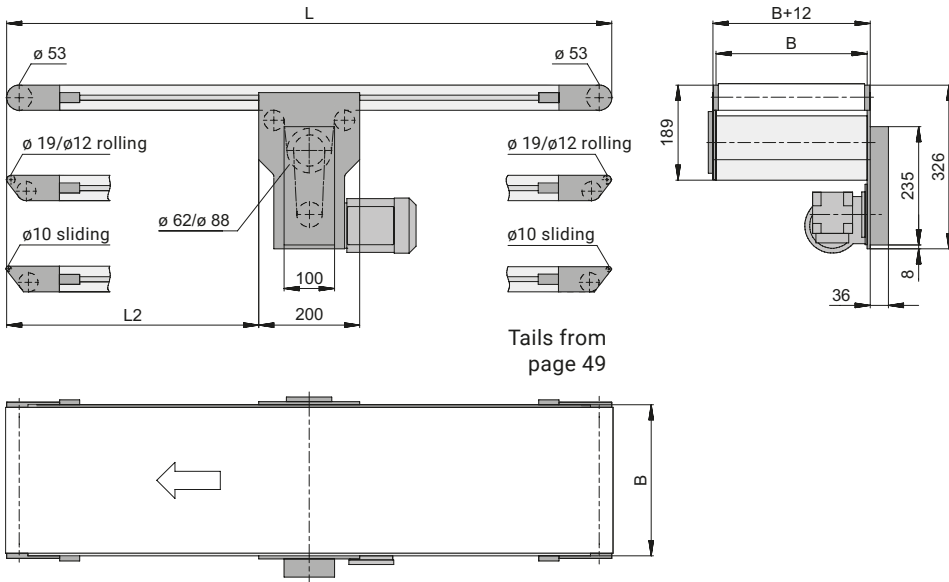

Technical data

Conveyor length L	individual from 700 to 10000 mm	
Conveyor width B	50, 75, 100, 150, 200, 250, 300, 400, 500, 600, 700, 800 mm	others on request
Belt width	B-10 mm	from p. 88
Drive location	left/right underneath	
Drive and speed	up to $v=80$ m/min	p. 12
Stand and side rail		from p. 280
Standard total load	up to 75 kg	p. 20
Standard distributed load	up to 25 kg/m	p. 20



Properties

Since the motor is fitted directly onto the drive shaft, the space requirements and maintenance effort for this drive version are reduced to a minimum. The compact conveyor frame design and the ability to freely select the drive position over the entire length of the conveyor make it easier to integrate the conveyor into existing systems. The conveying direction is reversible. Knife edges can be configured on both the infeed and discharge end. Operation with cleated belts is not possible with this version.

B20.00.012

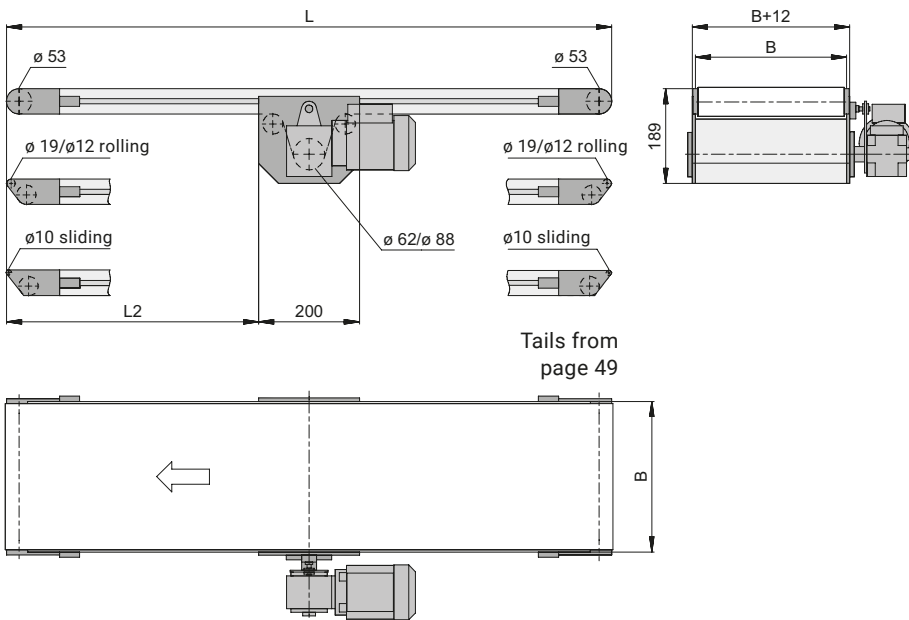

Technical data

Conveyor length L	individual from 700 to 10000 mm	
Conveyor width B	50, 75, 100, 150, 200, 250, 300, 400, 500, 600, 700, 800 mm	others on request
Belt width	B-10 mm	from p. 88
Drive location	left/right underneath	
Drive and speed	5; 6.3; 8; 9.5; 11.5; 13.5; 15.2; 19.3; 23; 26; 36.6; 45.7 and 57 m/min	p. 12
Stand and side rail		from p. 280
Standard total load	up to 75 kg	p. 20
Standard distributed load	up to 25 kg/m	p. 20

Properties

2

The drive version CA with drum motor is the most compact variant of the conveyors in the GUF-P 2000 system. Since the motor is integrated into the driving roller, no obstructing edges protrude over the conveyor frame structure. The conveyor can therefore easily be integrated into existing systems. Operation with cleated belts is not possible with this version.

B20.00.025

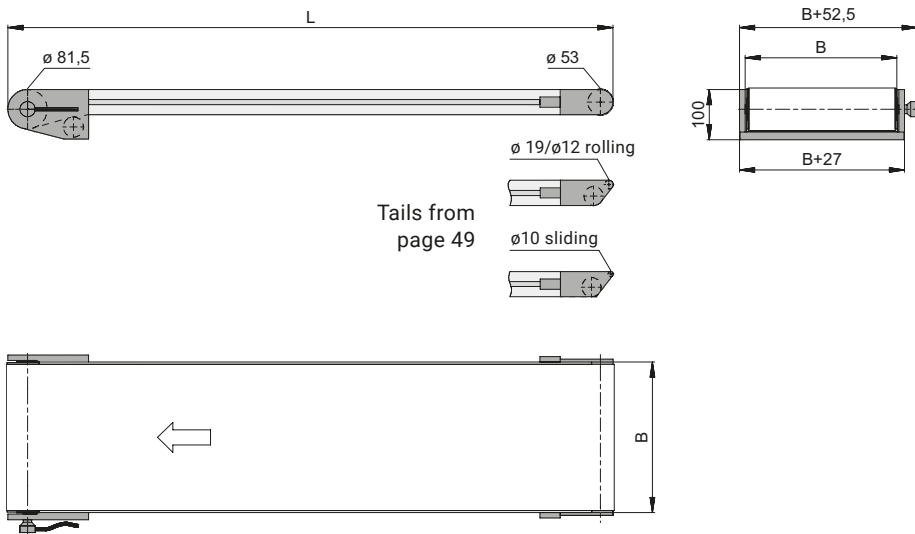

Technical data

Conveyor length L	individual from 440 to 10000 mm	
Conveyor width B	200, 250, 300, 350, 400, 500, 600, 700 and 800 mm	others on request
Belt width	B-10 mm	from p. 88
Drive location	discharge end left/right	
Drive and speed	up to $v=60$ m/min	p. 12
Stand and side rail		from p. 280
Standard total load	up to 55 kg	p. 20
Standard distributed load	up to 25 kg/m	p. 20

GUf-P 2000 Tails

2

Tail 01

Item no. B80.00.001

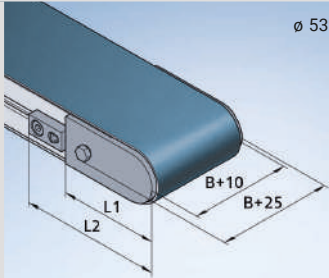

- Crowned roller, $\varnothing 53$ mm
- Ball bearing 2RS1
- Belt tensioning and adjustment on the side using the tensioning elements
- Min. length of the conveyed product for transfer of 114 mm

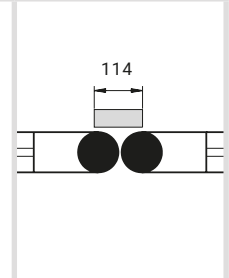

Conveyor length L	Conveyor width B	L1	L2	Head part material
$\leq 2,900$ mm	≤ 300 mm	105 mm	145 mm	Plastic
$\leq 2,900$ mm	> 300 mm	105 mm	145 mm	Aluminium
$> 2,900$ mm	≤ 800 mm	155 mm	195 mm	Aluminium

Tail 09

Item no. B80.00.005

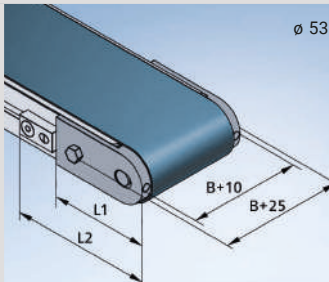

- Crowned roller, $\varnothing 53$ mm
- Ball bearing 2RS1
- Belt tensioning via head parts
- Belt adjustment from the front using threaded pins
- Obstructing edge-optimised tail
- Min. length of the conveyed product for transfer of 114 mm

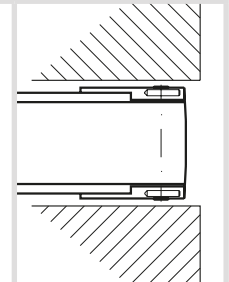

Conveyor length L	Conveyor width B	L1	L2	Head part material
$\leq 3,000$ mm	≤ 800 mm	105 mm	—	Aluminium

Tail 11

Item no. B80.00.007

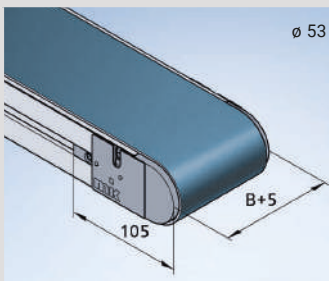

- Crowned roller, $\varnothing 53$ mm
- Ball bearing 2RS1
- Belt tensioning and adjustment on the side using the head parts (approx. 35 mm of clearance required on each side)
- Flush head parts
- Obstructing edge-optimised tail
- Min. length of the conveyed product for transfer of 114 mm

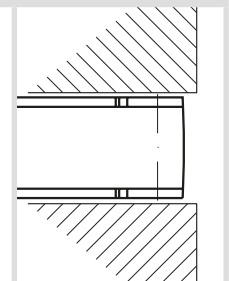

Conveyor length L	Conveyor width B	L1	L2	Head part material
$\leq 3,000$ mm	≤ 800 mm	105 mm	—	Aluminium

GUf-P 2000 Tails

2

Tail 19

Item no. B80.00.006

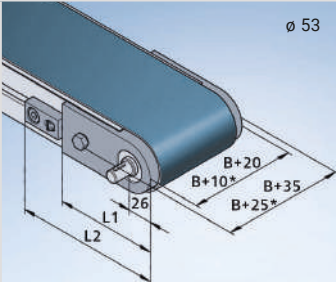

- Crowned roller, \varnothing 53 mm
- Ball bearing 2RS1
- \varnothing 16 mm shaft journal, usable length of 20 mm with roller for chain drive or 30 mm with roller for timing belt drive, keyway in accordance with DIN 6885
- Connection of two conveying lines through one drive
- Output shaft available on the right, left or both sides

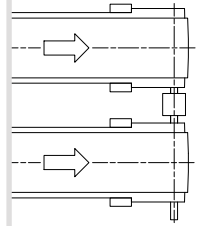

Conveyor length L	Conveyor width B	L1	L2	Head part material
$\leq 2,900$ mm	≤ 300 mm	105 mm	145 mm	Plastic
$\leq 2,900$ mm	> 300 mm	105 mm	145 mm	Aluminium
$> 2,900$ mm	≤ 800 mm	155 mm	195 mm	Aluminium

*Does not apply for the drive end

Tail 13

Item no. B80.00.018

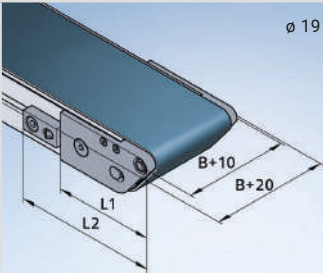

- Rolling knife edge
- \varnothing 19 mm roller, ball bearing 2RS1
- Belt tensioning on the side using tensioning elements
- Adjustment using tensioning elements
- Min. length of the conveyed product for transfer of 48 mm
- Note the min. bend radius for the desired belt

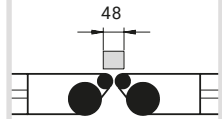

Conveyor length L	Conveyor width B	L1	L2	Head part material
$\leq 3,000$ mm	≤ 800 mm	116 mm	156 mm	Aluminium
$> 3,000$ mm	≤ 800 mm	166 mm	206 mm	Aluminium

Tail 10

Item no. B80.00.017

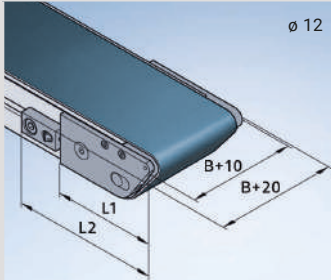

- Rolling knife edge
- $\varnothing 12$ mm roller, ball bearing 2RS1
- Belt tensioning on the side using tensioning elements
- Adjustment from the front using tensioning roller
- Min. length of the conveyed product for transfer of 34 mm
- Note the min. bend radius for the desired belt
- Max. conveying speed of 30 m/min
- Max. load capacity of 5 kg per 50 mm conveyor width

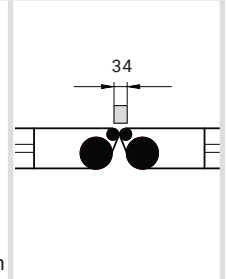

Conveyor length L	Conveyor width B	L1	L2	Head part material
$\leq 3,000$ mm	≤ 300 mm	111 mm	151 mm	Aluminium
$> 3,000$ mm	≤ 300 mm	161 mm	201 mm	Aluminium

Tail 17

Item no. B80.00.002

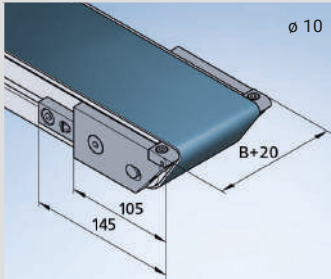

- Stationary knife edge
- Belt tensioning on the side using tensioning elements
- Adjustment from the front using tensioning roller
- Min. length of the conveyed product for transfer of 30 mm
- Note the min. bend radius for the desired belt
- Max. conveying speed of 10 m/min
- Requires driving roller with rubber coating

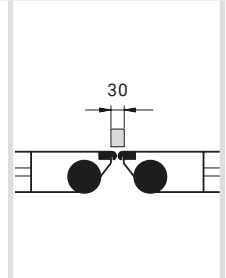

Conveyor length L	Conveyor width B	L1	L2	Head part material
$\leq 3,000$ mm	≤ 300 mm	105 mm	145 mm	Aluminium

Belt Conveyor GUF-P 2041

2



» For applications with high load capacities and wide conveyed products. «

The torsion-resistant conveyor frame based on the mk 2251 profile (50 x 80 mm) allows for high load capacities. Drive and tail components are also designed according to these load capacities.

The \varnothing 85 mm driving roller used in this conveyor system also features excellent grip for transmitting the motor power to the belt. A major benefit of this system is its nearly unlimited selection of different belt types for use in combination with cleats and side walls.

In addition to these benefits, the two system slots (10 mm slot width) on each side give you maximum flexibility for integrating the conveyor system into existing systems or for attaching stands, side rails and other accessories. Other high-quality features include crowned rollers for simple belt adjustment and a wear-resistant belt slide bed made from galvanised steel.

Benefits of the GUF-P 2041

- For high load capacities and wide product
- Built with the profile mk 2251 for a high load capacity and torsion-resistant structure
- Wide range of different drives, tails, stands and belt types
- Optionally available with a compact drum motor and knife edge
- Flexible operation in reverse, accumulated and cycling mode

Cross Section

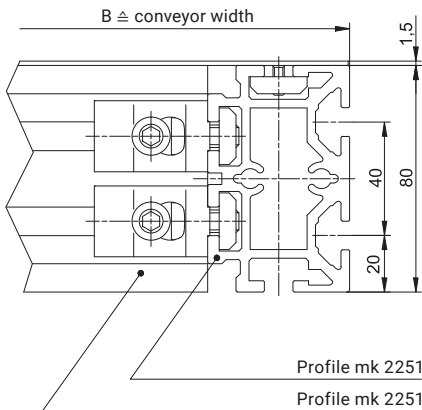

Properties

2

The drive variant AA without a motor offers the advantage of operating multiple conveyor belts in parallel or in series with one drive. The compact conveyor frame design makes it easier to integrate the conveyor into existing systems. The driving roller $\varnothing 85$ mm has a round design for simple belt control. Operation with cleated belts is possible with this version. The $\varnothing 20$ mm shaft journal with a length of 27.5 mm is designed with a DIN 6885 key.

B20.40.009

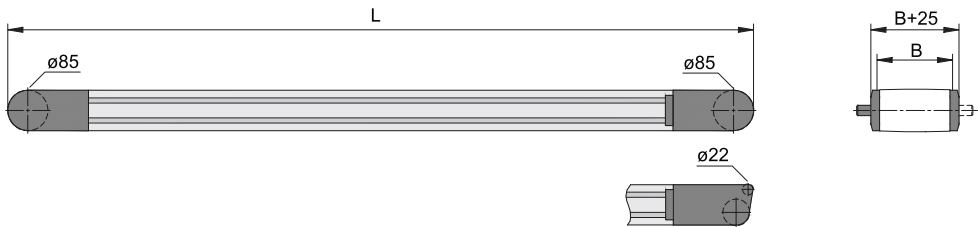

Drive shaft on both sides also possible.
Please specify when ordering.

Tails from
page 60



Technical data

Conveyor length L	individual from 540 to 10000 mm	
Conveyor width B	200 to 1200 mm (in 100 mm increments)	others on request
Belt width	B-15 mm	from p. 88
Drive and speed	up to $v=60$ m/min	p. 12
Stand and side rail		from p. 280
Standard total load	up to 150 kg	p. 20
Standard distributed load	up to 50 kg/m	p. 20



Properties

The compact conveyor frame design with the most popular drive variants makes it easier to integrate the conveyor into existing systems. The $\varnothing 85$ mm driving roller ensures excellent transmission of the motor power. Operation with cleated belts is possible with this version.

B20.40.001

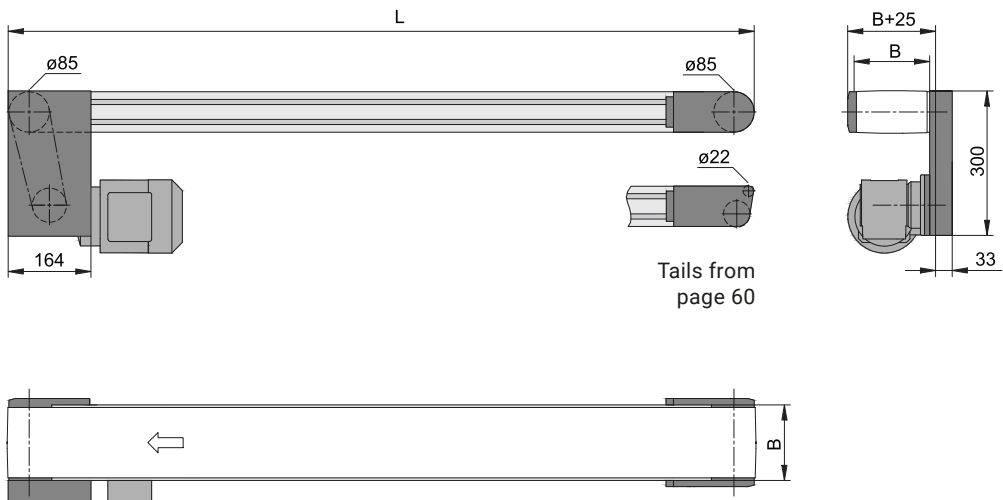

Technical data

Conveyor length L	individual from 540 to 10000 mm	
Conveyor width B	200 to 1200 mm (in 100 mm increments)	others on request
Belt width	B-15 mm	from p. 88
Drive location	discharge end left/right, underneath/above, infeed on request	
Drive and speed	up to $v=60$ m/min	p. 12
Stand and side rail		from p. 280
Standard total load	up to 150 kg	p. 20
Standard distributed load	up to 50 kg/m	p. 20

Properties

2

Since the motor is fitted directly onto the drive shaft, the space requirements and maintenance effort for this drive version are reduced to a minimum.

B20.40.008

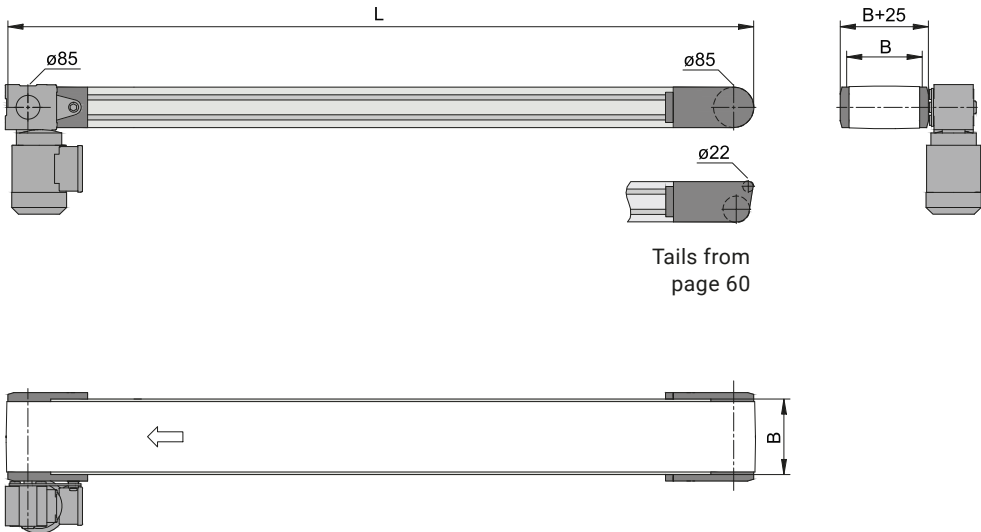

Technical data

Conveyor length L	individual from 560 to 10000 mm	
Conveyor width B	200 to 1200 mm (in 100 mm increments)	others on request
Belt width	B-15 mm	from p. 88
Drive location	discharge end left/right; infeed end on request	
Drive and speed	4.7; 6; 7.5; 9; 11; 13; 14.5; 18.5; 22; 25; 35; 43.5 and 54.5 m/min	p. 12
Stand and side rail		from p. 280
Standard total load	up to 100 kg	p. 20
Standard distributed load	up to 50 kg/m	p. 20



Properties

The drive positioned laterally on the outside allows the total height of the conveyor to be restricted to a minimum. The $\varnothing 85$ mm driving roller ensures excellent transmission of the motor power. Operation with cleated belts is possible with this version.

B20.40.003

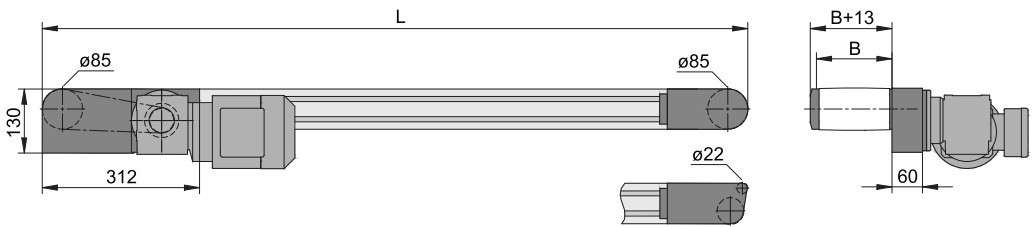

Tails from
page 60

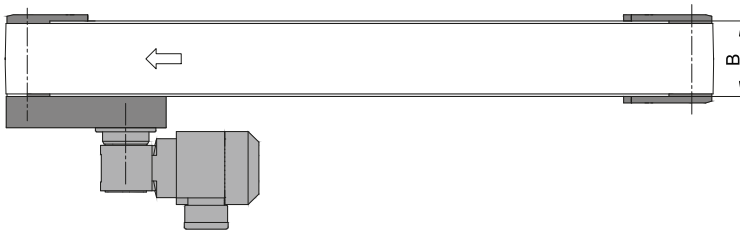

Technical data

Conveyor length L	individual from 700 to 10000 mm	
Conveyor width B	200 to 1200 mm (in 100 mm increments)	others on request
Belt width	B-15 mm	from p. 88
Drive location	discharge end left/right; infeed end on request	
Drive and speed	up to $v=60$ m/min	p. 12
Stand and side rail		from p. 280
Standard total load	up to 150 kg	p. 20
Standard distributed load	up to 50 kg/m	p. 20

Properties

2

The compact conveyor frame design and the ability to freely select the drive position over the entire length of the conveyor make it easier to integrate the conveyor into existing systems. The conveying direction is reversible. Knife edges can be configured on both the infeed and discharge end. Operation with cleated belts is not possible with this version.

B20.40.004

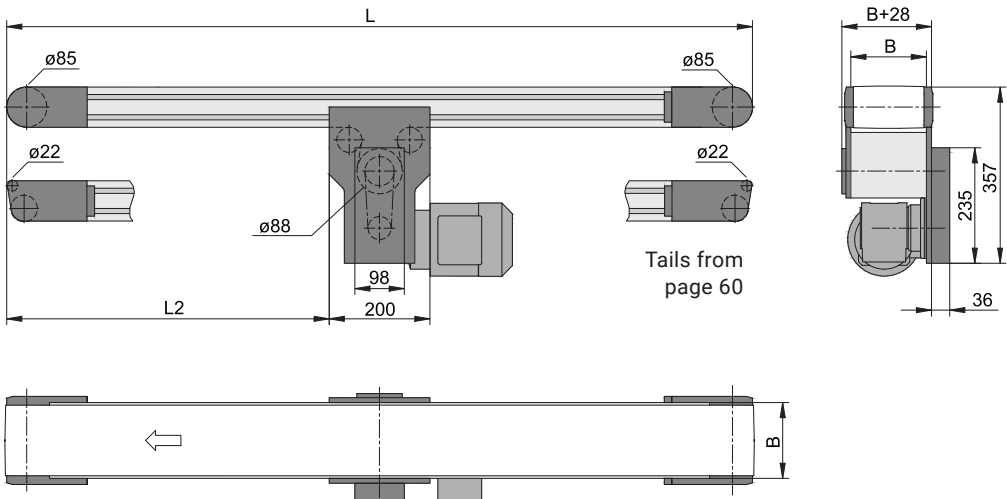

Technical data

Conveyor length L	individual from 800 to 10000 mm	
Conveyor width B	200 to 1200 mm (in 100 mm increments)	others on request
Belt width	B-15 mm	from p. 88
Drive location	left/right underneath	
Drive and speed	up to $v=60$ m/min	p. 12
Stand and side rail		from p. 280
Standard total load	up to 150 kg	p. 20
Standard distributed load	up to 50 kg/m	p. 20



Properties

The drive version CA with drum motor is the most compact variant of the conveyors in the GUF-P 2041 system. Since the motor is integrated into the driving roller, no obstructing edges protrude over the conveyor frame structure. The conveyor can therefore easily be integrated into existing systems.

B20.40.005

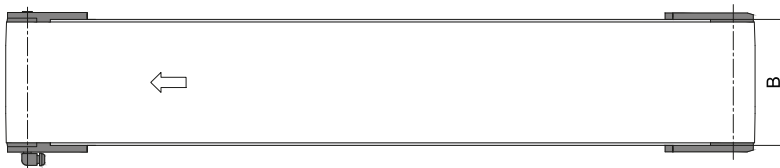
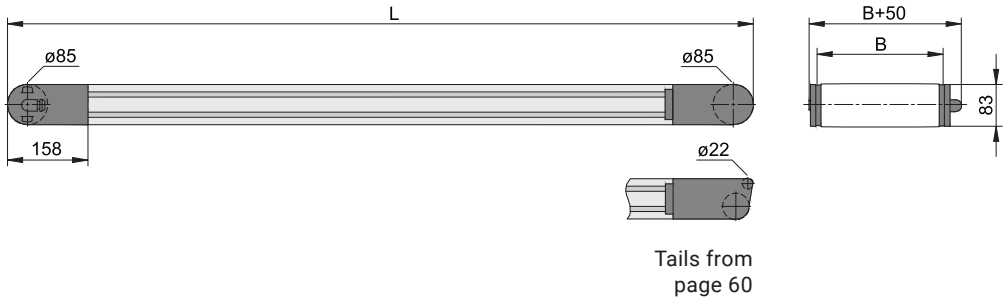

Technical data

Conveyor length L	individual from 540 to 3000 mm	
Conveyor width B	200, 250, 300, 350, 400, 500, 600, 700, 800, 900 and 1000 mm	others on request
Belt width	B-15 mm	from p. 88
Drive location	discharge end left/right	
Drive and speed	up to $v=60$ m/min	p. 12
Stand and side rail		from p. 280
Standard total load	up to 55 kg	p. 20
Standard distributed load	up to 50 kg/m	p. 20

GUf-P 2041 Tails

2

Tail 01

Item no. B80.07.001

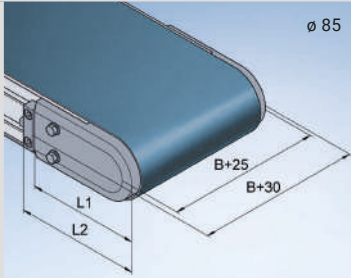

- Crowned roller, \varnothing 85 mm
- Ball bearing 2RS1
- Belt tensioning and adjustment on the side using the tensioning elements
- Min. length of the conveyed product for transfer of 180 mm

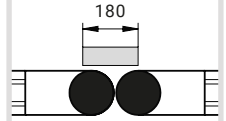

Conveyor length L	Conveyor width B	L1	L2	Head part material
$\leq 3,000$ mm	$\leq 1,200$ mm	160 mm	175 mm	Aluminium
$\leq 3,000$ mm	$\leq 1,200$ mm	250 mm	265 mm	Aluminium

Tail 02

Item no. B80.07.009

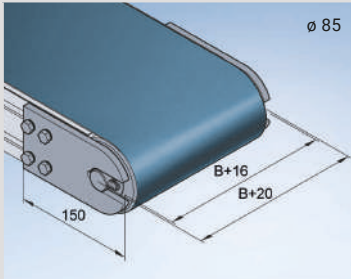

- \varnothing 85 mm cylindrical roller
- Ball bearing 2RS1
- Belt tensioning and adjustment from the front using tensioning axles
- Min. conveyed product length of 180 mm for transfer
- Only for outputting conveyed product in longitudinal direction

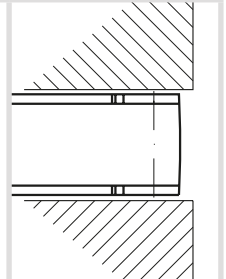

Conveyor length L	Conveyor width B	L1	L2	Head part material
$\leq 3,000$ mm	$\leq 1,200$ mm	150 mm	—	Aluminium

Tail 13

Item no. B80.07.010

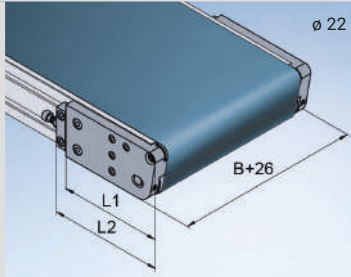

- Roller, $\phi 22$ mm
- Ball bearing 2RS1
- Belt tensioning on the side using tensioning elements
- Adjustment using tracking roller
- Min. length of the conveyed product for transfer of 54 mm
- Note the min. bend radius for the desired belt

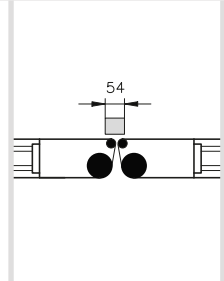

Conveyor length L	Conveyor width B	L1	L2	Head part material
$\leq 3,000$ mm	$\leq 1,200$ mm	158 mm	173 mm	Aluminium, short
$> 3,000$ mm	$\leq 1,200$ mm	220 mm	235 mm	Aluminium, long

Tail 19

Item no. B80.07.002

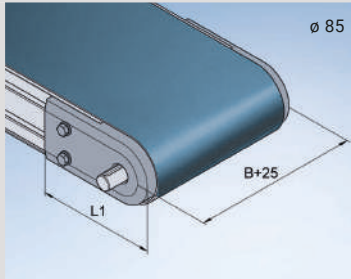

- Crowned roller, $\phi 85$ mm
- Ball bearing 2RS1
- $\phi 20$ shaft journal, length of 27.5 mm, keyway in accordance with DIN 6885
- Connection of two conveying lines through one drive
- Output shaft available on the left, right or both sides

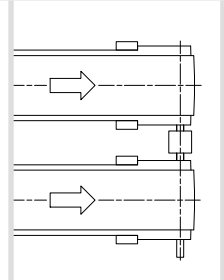

Conveyor length L	Conveyor width B	L1	L2	Head part material
$\leq 3,000$ mm	$\leq 1,200$ mm	160 mm	—	Aluminium
$> 3,000$ mm	$\leq 1,200$ mm	250 mm	—	Aluminium

Belt Conveyor GUF-P 2004

2

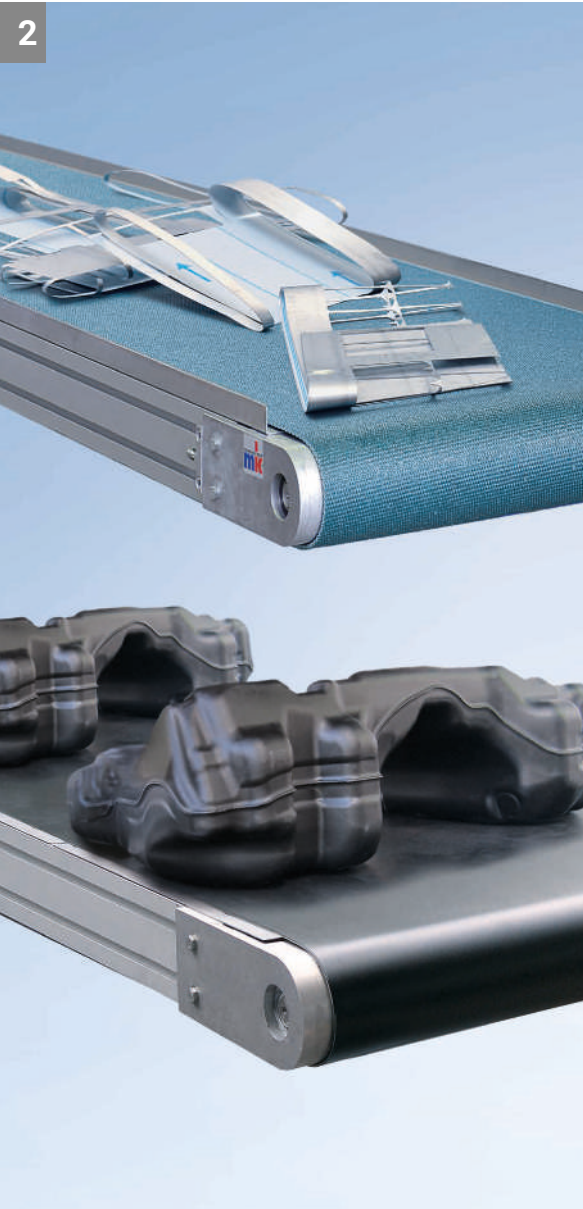

» Ideal for conveying bulky or heavy products. «

Alongside some of the standard features of mk belt conveyor systems, such as crowned rollers for better belt adjustment and wear-resistant belt slide beds made from galvanised steel, a special feature of the GUF-P 2004 system is its stable structure based on the mk 2004 profile.

Capable of handling a total load of up to 200 kg and products up to 2,000 mm wide and 20,000 mm long, this torsion-resistant conveyor frame is perfect for transporting bulky product. The \varnothing 105 mm driving roller, which can be coated in rubber depending on the load and conveyor width, ensures excellent transmission of the motor power to the belt.

The transport system can be supplemented with a large variety of accessory components tailored to the heavy transport weights, including side rails and stands with a reinforced design.

Benefits of the GUF-P 2004

- For very high load capacities and bulky product
- Built with the mk 2004 profile for very high load capacity and a torsion-resistant structure
- Reinforced stands and side rails available for variable configuration
- Flexible operation in reverse, accumulated and cycling mode

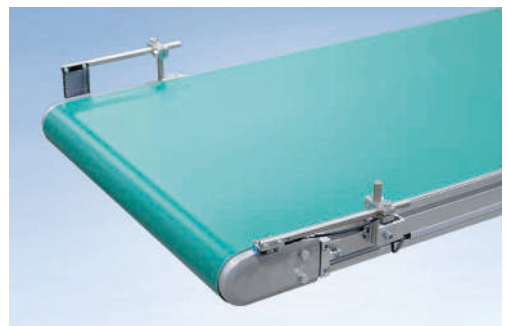
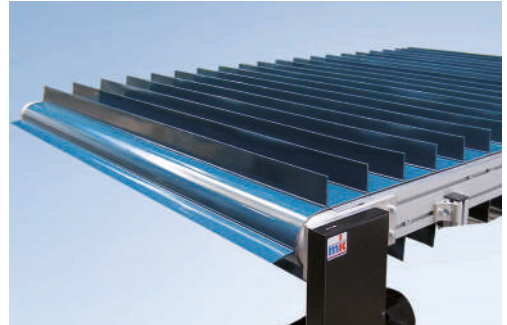

Cross Section

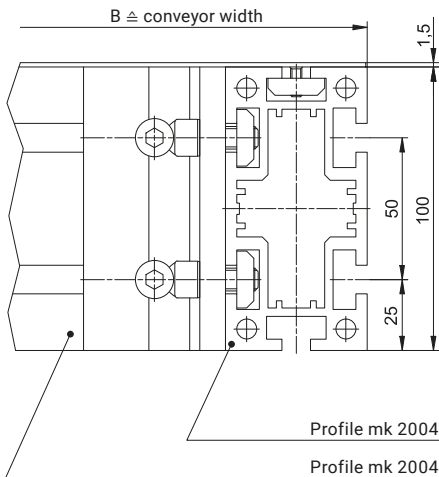

Properties

The drive variant AA without a motor offers the advantage of operating multiple conveyor belts in parallel or in series with one drive. The compact conveyor frame design makes it easier to integrate the conveyor into existing systems. The driving roller $\varnothing 105$ mm has a round design for simple belt control. Operation with cleated belts is possible with this version. The $\varnothing 22$ mm shaft journal with a length of 32 mm is designed with a DIN 6885 key.

B20.14.009

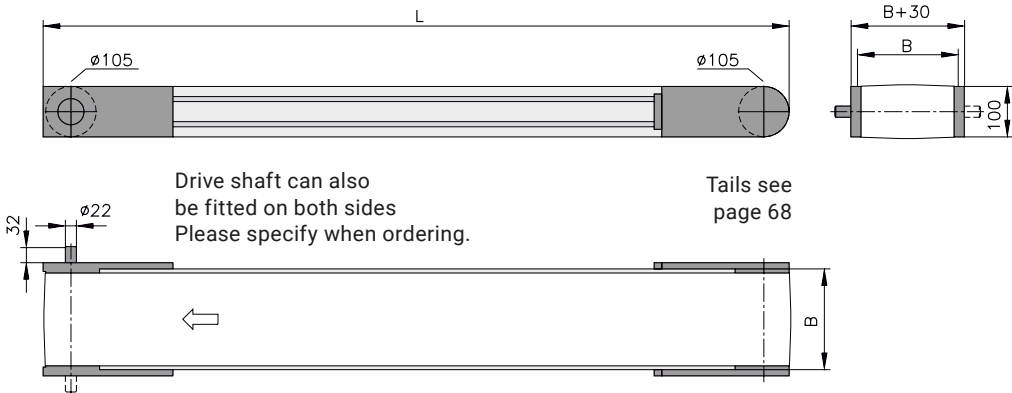

Technical data

Belt length L	individual from 720 to 20000 mm	
Conveyor width B	200 to 2000 mm (in 100 mm increments)	others on request
Belt width	B-50 mm	from p. 88
Drive and speed	up to $v=60$ m/min	
Stand and side rail		from p. 280
Standard total load	up to 200 kg	p. 20
Standard distributed load	up to 75 kg/m	p. 20



Properties

The compact conveyor frame design with the most popular drive variants makes it easier to integrate the conveyor into existing systems. The $\varnothing 105$ mm driving roller ensures excellent transmission of the motor power. Operation with cleated belts is possible with this version.

B20.14.001

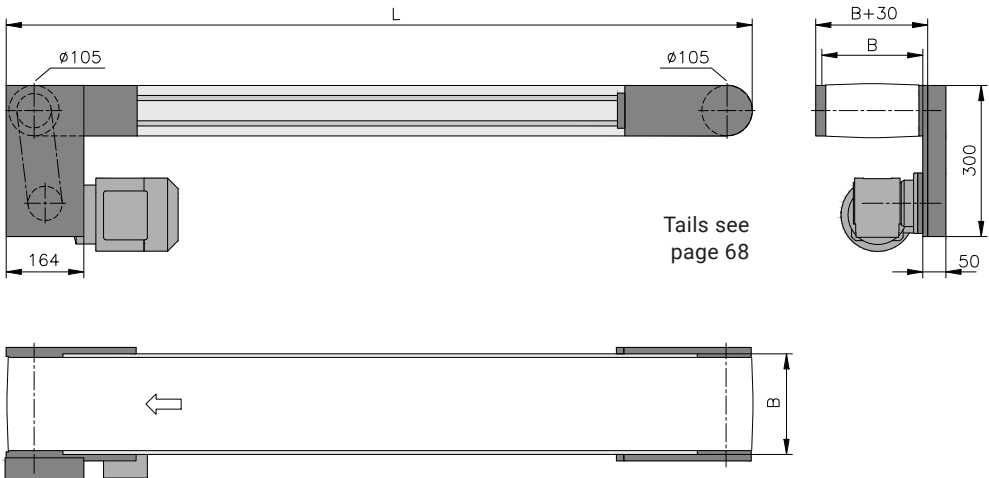

Technical data

Belt length L	individual from 720 to 20000 mm	
Conveyor width B	200 to 2000 mm (in 100 mm increments)	others on request
Belt width	B-50 mm	from p. 88
Drive location	discharge end left/right, underneath/above, infeed on request	
Drive and speed	up to $v=60$ m/min	p. 12
Stand and side rail		from p. 280
Standard total load	up to 200 kg	p. 20
Standard distributed load	up to 75 kg/m	p. 20

Properties

The compact conveyor frame design with the offset drive makes it easier to integrate the conveyor into existing systems. The $\varnothing 105$ mm driving roller ensures excellent transmission of the motor power. Operation with cleated belts is possible with this version.

B20.14.003

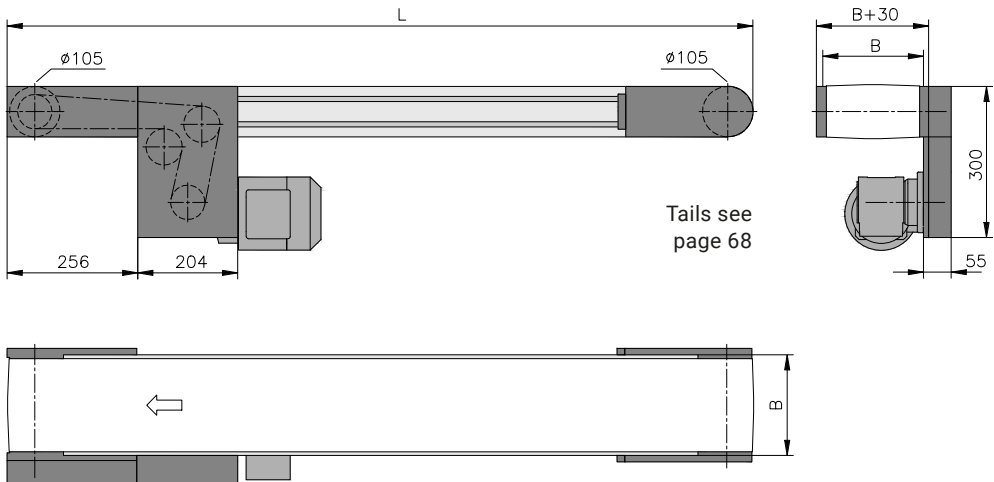

Technical data

Belt length L	individual from 920 to 20000 mm	
Conveyor width B	200 to 2000 mm (in 100 mm increments)	others on request
Belt width	B-50 mm	from p. 88
Drive location	discharge end left/right, underneath; infeed end on request	
Drive and speed	up to $v=60$ m/min	p. 12
Stand and side rail		from p. 280
Standard total load	up to 200 kg	p. 20
Standard distributed load	up to 75 kg/m	p. 20



Properties

The drive positioned laterally on the outside allows the total height of the conveyor to be restricted to a minimum. The $\varnothing 105$ mm driving roller ensures excellent transmission of the motor power. Operation with cleated belts is possible with this version.

B20.14.002

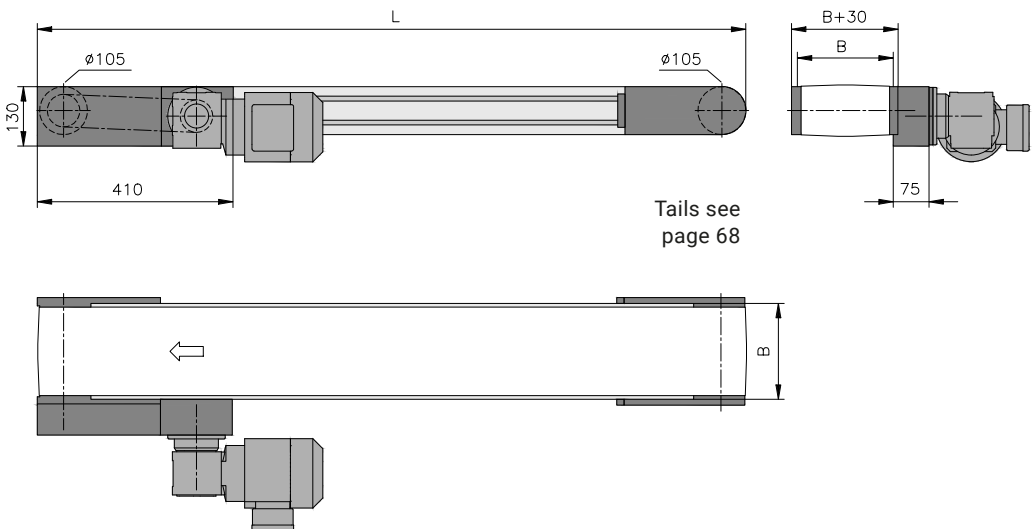

Technical data

Belt length L	individual from 870 to 20000 mm	
Conveyor width B	200 to 2000 mm (in 100 mm increments)	others on request
Belt width	B-50 mm	from p. 88
Drive location	discharge end left/right; infeed end on request	
Drive and speed	up to $v=60$ m/min	p. 12
Stand and side rail		from p. 280
Standard total load	up to 200 kg	p. 20
Standard distributed load	up to 75 kg/m	p. 20

GUF-P 2004 Tails

2

Tail 01

Item no. B80.02.004

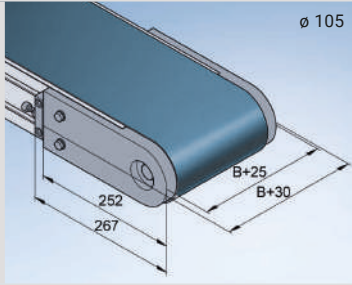

- Crowned roller, ϕ 105 mm
- Ball bearing 2RS1
- Belt tensioning and adjustment on the side using the tensioning elements
- Min. length of the conveyed product for transfer of 220 mm

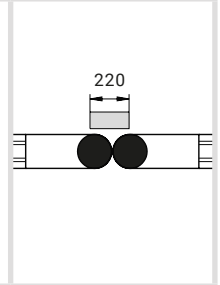

Tail 09

Item no. B80.02.005

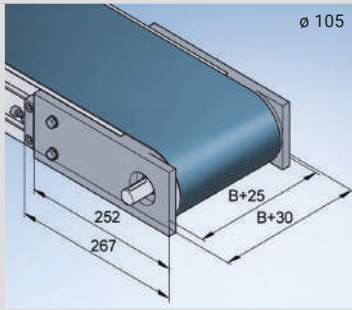

- Crowned roller, ϕ 105 mm
- Ball bearing 2RS1
- Belt tensioning and adjustment on the side using the tensioning elements
- ϕ 22 shaft journal, length of 32 mm, keyway in accordance with DIN 6885
- Connection of two conveying lines through one drive
- Output shaft available on the right, left or both sides
- Protruding head part (conveyor length $L+5$ mm)

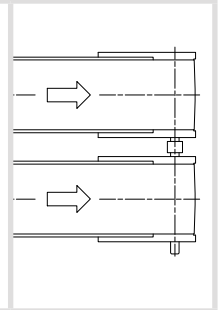

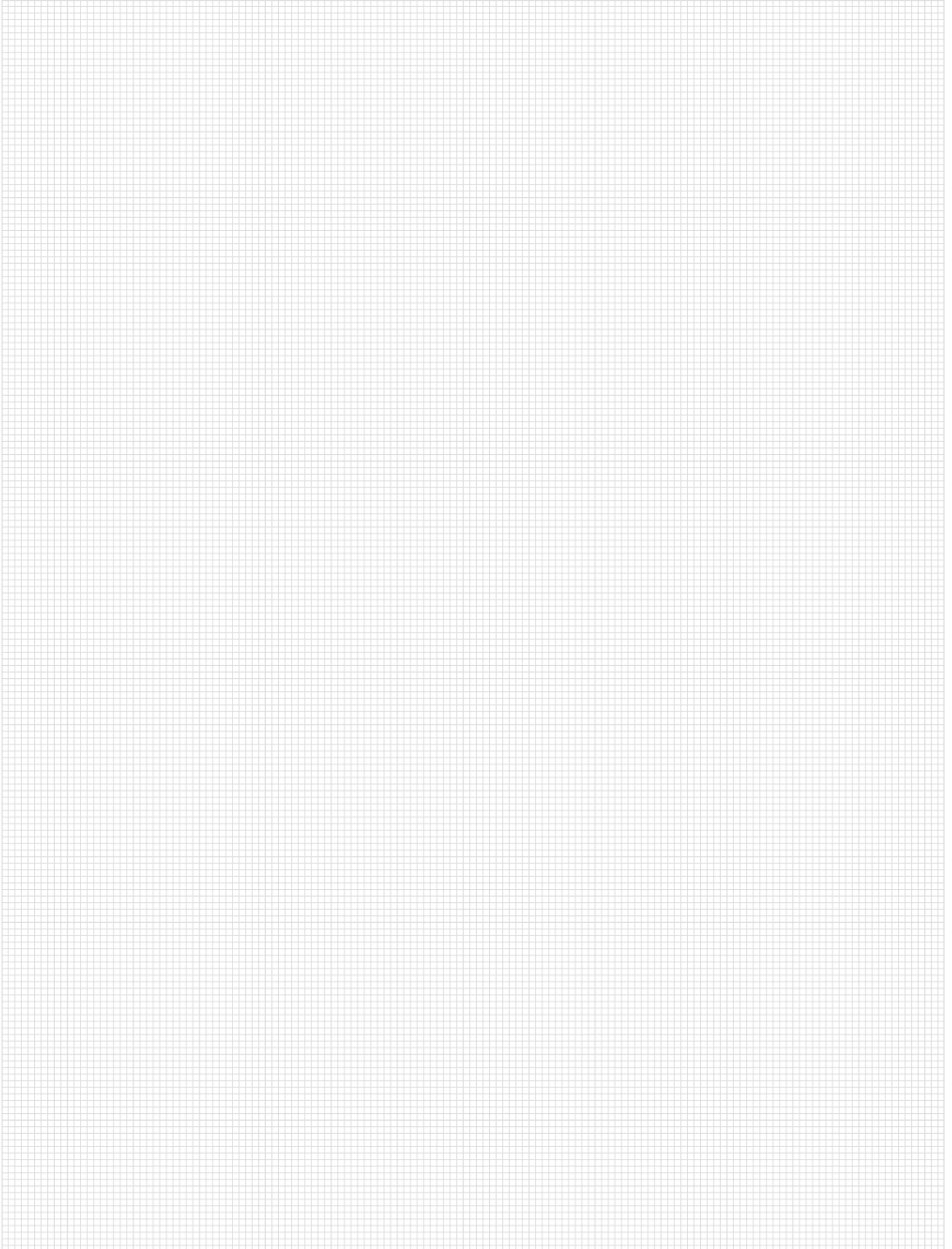

Incline Conveyor Belt KFG-P 2000

2



» Suitable for mobile use for vertical transport of small parts. «

The KFG-P 2000 and KFG-P 2000 ECO conveyor systems are based on the mk 2000 profile and their compact conveyor frame design makes them ideal for demanding continuous duty in multi-shift operation. As with all mk belt conveyor systems, the round driving rolls make it easy to adjust the belt. On inclines, the belt is guided by welded-on longitudinal profiles.

Another quality feature is the stainless steel sheet installed below the belt running surface, which ensures long-term wear resistance. This conveyor system is primarily used to transport small parts (made from plastic, for instance).

The modular design of the conveyor system combined with the general advantages of profile technology make the conveyor excellently suited for integration into existing systems or for use as a mobile transport unit (e.g. for filling containers).

Benefits of the KFG-P 2000

- Vertical transport for connecting different heights
- Moving transport unit for mobile use
- Ideal for integration into existing systems
- Compliant with the applicable Machinery Directive and occupational safety regulations – additional protective device guard not required
- Belts can be replaced with little work
- Optional cycling operation and control with a frequency inverter
- Optional motor overload switch

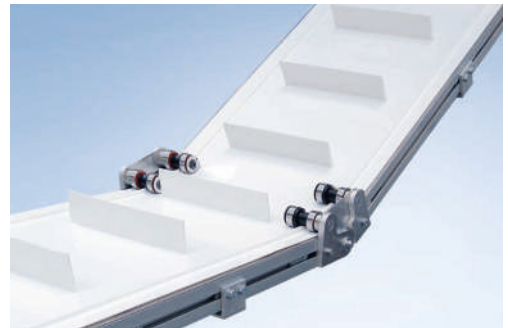

Cross Section

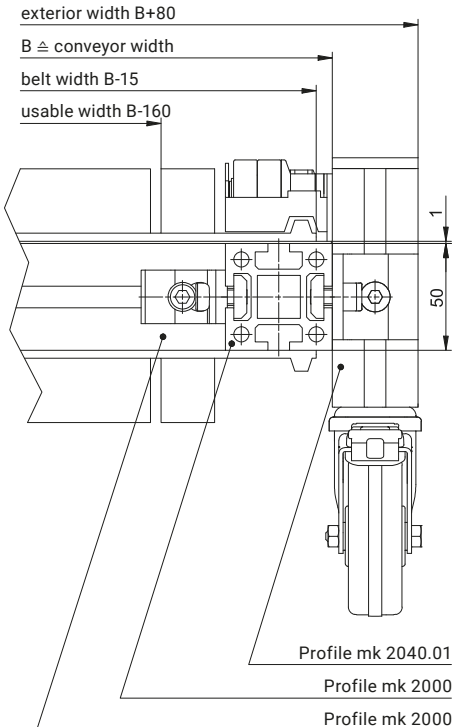

Properties

2

The compact conveyor frame design with the most popular drive variants makes it easier to integrate the conveyor into existing systems. The $\varnothing 53$ mm driving roller ensures excellent transmission of the motor power.

B20.00.010

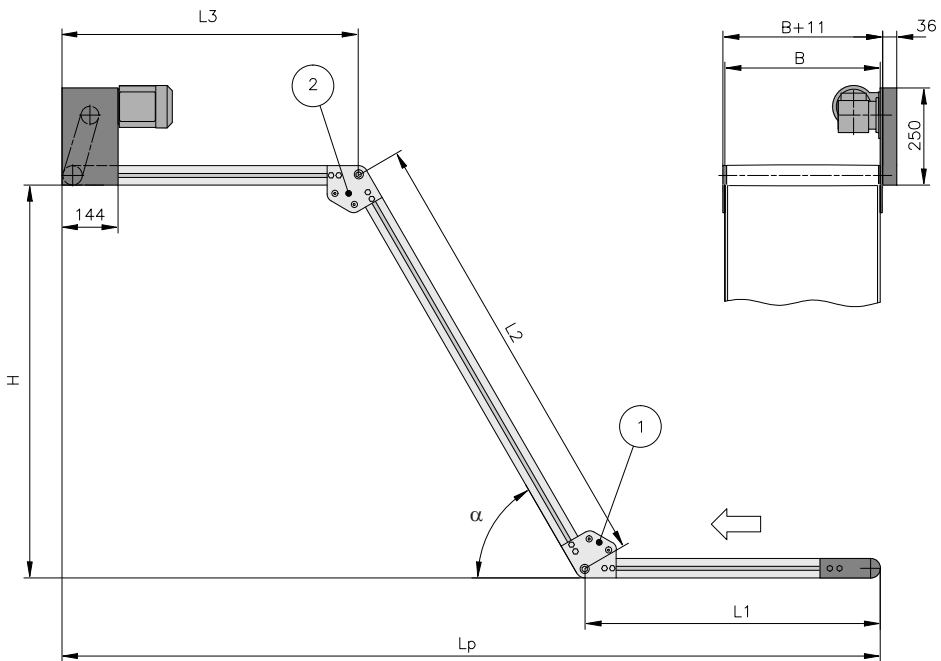

Technical data

Conveyor length L (L1+L2+L3)	variable up to approx. 4000 mm L1/L3 min. = 400, L2 min. = 600	
Conveyor width B	300 to 700 mm (in 100 mm increments)	others on request
Drive location	discharge end left/right, underneath/above	
Drive and speed	up to 15 m/min	others on request
Stand and side rail		p. 78
Standard total load	up to 40 kg	higher on request
Standard distributed load	up to 25 kg/m, 5 kg/compartments	others on request
Belt incline α	30, 45 and 60°	others on request
Conveyed product	height up to 55 mm, length up to 300 mm	others on request



Properties

Since the motor is fitted directly onto the drive shaft, the space requirements and maintenance effort for this drive version are reduced to a minimum.

2

B20.00.010

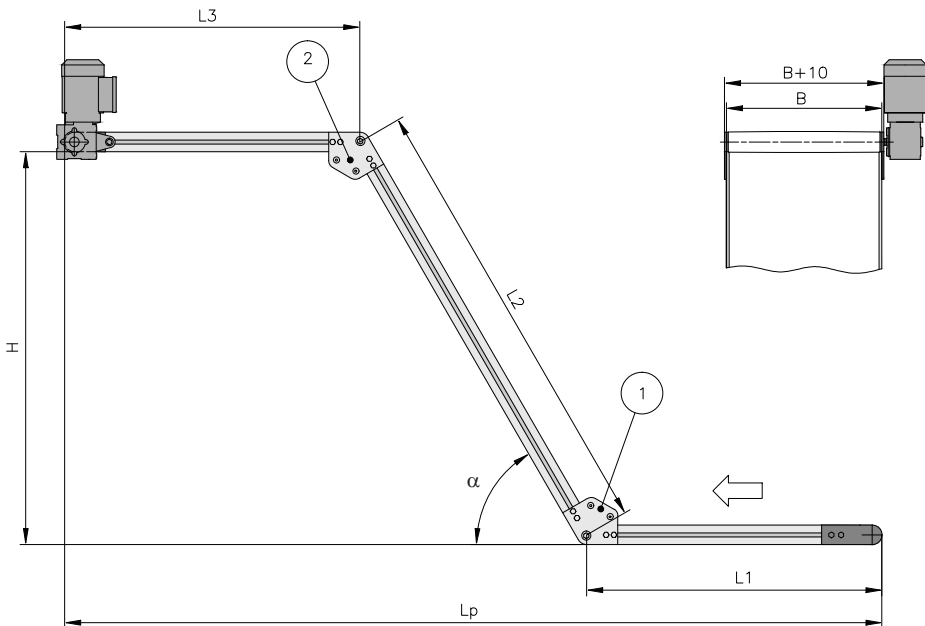

Technical data

Conveyor length L (L1+L2+L3)	variable up to approx. 4000 mm L1/L3 min. = 400, L2 min. = 600	
Conveyor width B	300 to 700 mm (in 100 mm increments)	others on request
Drive location	discharge end left/right	
Drive and speed	2.8, 5.5, 11.2, 15.2 m/min	others on request
Stand and side rail		p. 78
Standard total load	up to 40 kg	higher on request
Standard distributed load	up to 25 kg/m, 5 kg/compartment	others on request
Belt incline α	30, 45 and 60°	others on request
Conveyed product	height up to 55 mm, length up to 300 mm	others on request

Properties

The drive located laterally on the outside allows the total height of the conveyor to be restricted to a minimum. The compact conveyor frame design makes it easier to integrate the conveyor into existing systems. The $\varnothing 53$ mm driving roller ensures excellent transmission of the motor power.

B20.00.010

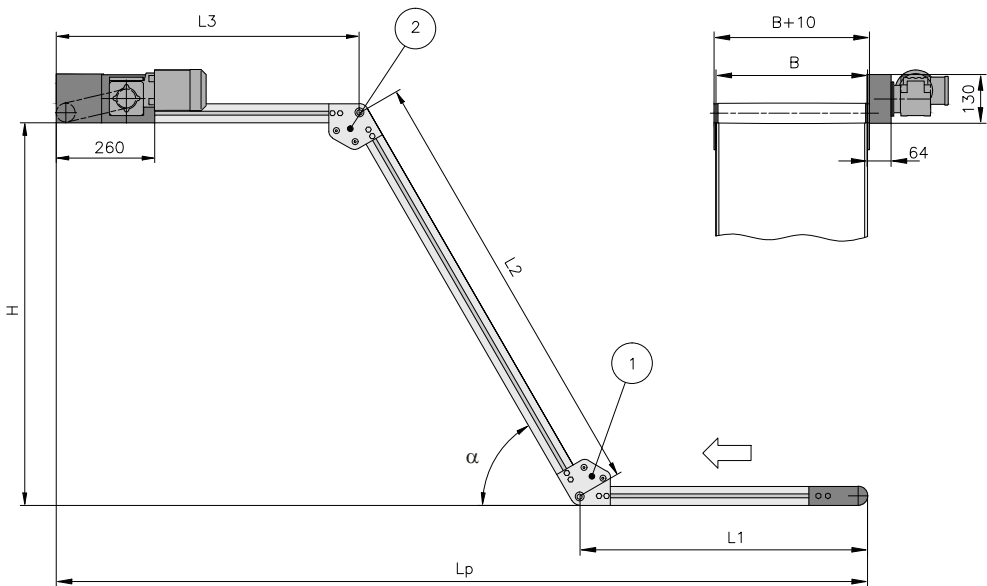

Technical data

Conveyor length L (L1+L2+L3)	variable up to approx. 4000 mm L1/L3 min. = 400, L2 min. = 600	
Conveyor width B	300 to 700 mm (in 100 mm increments)	others on request
Drive location	discharge end left/right	
Drive and speed	up to 15 m/min	others on request
Stand and side rail		p. 78
Standard total load	up to 40 kg	higher on request
Standard distributed load	up to 25 kg/m, 5 kg/compartment	others on request
Belt incline α	30, 45 and 60°	others on request
Conveyed product	height up to 55 mm, length up to 300 mm	others on request



Properties

The advantage of the drive version AU is that the motor is fitted on the outside of the conveyor belt. The compact conveyor frame design makes it easier to integrate the conveyor into existing systems. The $\varnothing 53$ mm driving roller ensures excellent transmission of the motor power.

2

B20.00.010

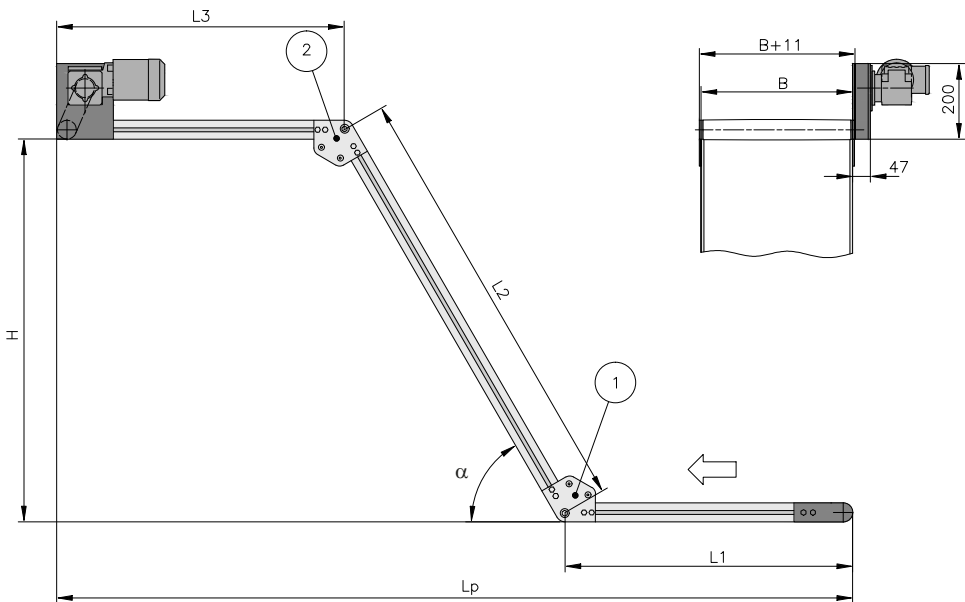

Technical data

Conveyor length L (L1+L2+L3)	variable up to approx. 4000 mm L1/L3 min. = 400, L2 min. = 600	
Conveyor width B	300 to 700 mm (in 100 mm increments)	others on request
Drive location	discharge end left/right, underneath/above	
Drive and speed	up to 15 m/min	others on request
Stand and side rail		p. 78
Standard total load	up to 40 kg	higher on request
Standard distributed load	up to 25 kg/m, 5 kg/compartiment	others on request
Belt incline α	30, 45 and 60°	others on request
Conveyed product	height up to 55 mm, length up to 300 mm	others on request

KFG-P 2000 ECO

Properties

2

ECO stands for economy: which means high quality materials and meeting customer requirements at an attractive price. The limited number of variants ensures fast delivery and high availability. With the optimal ratio of effective width to total width, the conveyor is ideal for integration in existing systems. Its mobility means it can be used as a versatile transport unit for filling containers or pallet cages.

B20.00.015

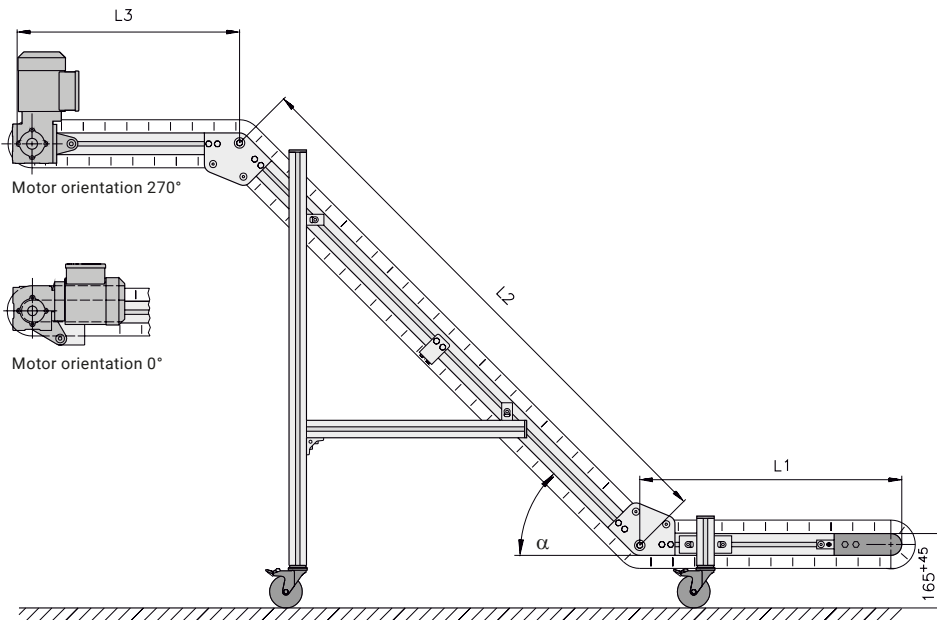

Technical data

Conveyor length L (L1+L2+L3)	2400/2900 mm (L1 = 600 mm, L2 = 1300/1800 mm, L3 = 500 mm)
Conveyor width B	400, 500, 600 mm (usable width: B-160 mm)
Drive location	discharge end left/right, above, 270° motor orientation, 0° for surcharge
Drive and speed	2.8; 5.5; 11.2; 15.2 m/min, others on request or with reglomat
Load capacity	depending on conveying angle and speed, up to 40 kg
Belt incline α	30, 45 and 60°
Conveyed product	height up to 55 mm, length up to 300 mm, weight up to 5 kg/compartment
Belt	GU-V0106-028DG
Cleats and side walls	high transverse cleats MT30 and 30 mm side wall, polyurethane, green with L2=1300, 16 transverse cleats with 303 mm between cleats with L2=1800, 19 transverse cleats with 308 mm between cleats

Variants

2

B20.00.015

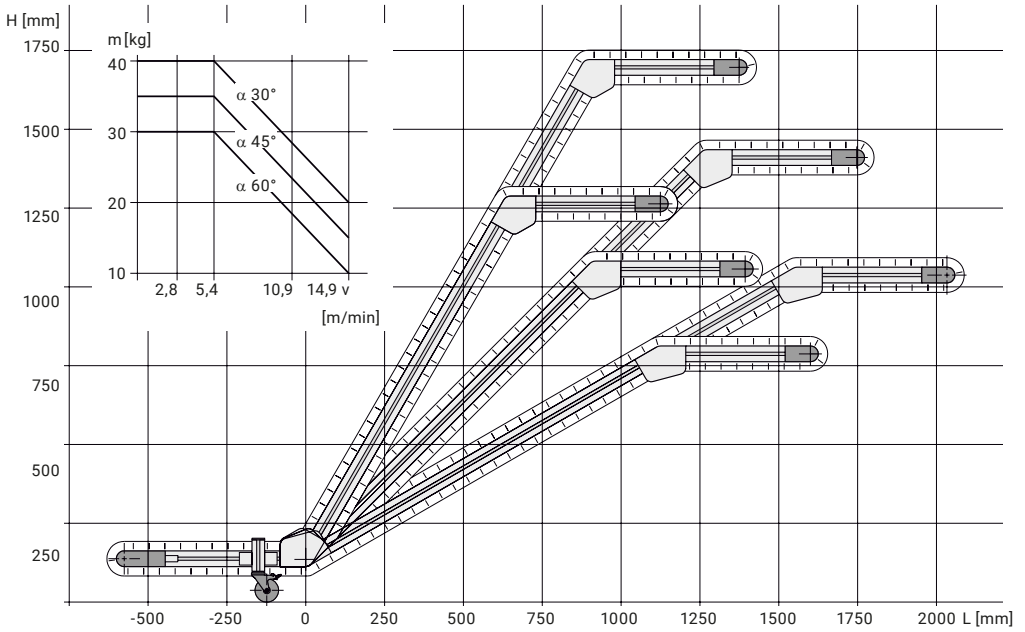

See the table for the optimal variant for your application. Without additional specifications, the conveyor is designed with a top, front left, 270° drive location and speed of 5.4 m/min.

Variant (L2 1300 mm)	A1	A2	A3	A4	A5	A6	A7	A8	A9
Conveyor width B [mm]	400	400	400	500	500	500	600	600	600
Belt incline α	30°	45°	60°	30°	45°	60°	30°	45°	60°

Variant (L2 1800 mm)	B1	B2	B3	B4	B5	B6	B7	B8	B9
Conveyor width B [mm]	400	400	400	500	500	500	600	600	600
Belt incline α	30°	45°	60°	30°	45°	60°	30°	45°	60°



KFG-P 2000

Stand Type ECO

The stand was developed specially for the incline conveyor belt and incline conveyor modular belt and is characterised by its simplicity and light-weight design with the mk 2040.40 profile.

Infeed End Stand B67.06.014

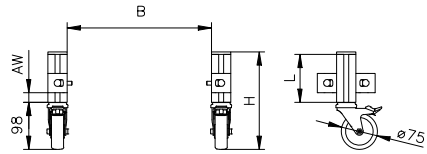

Infeed height (ELH) = 166–349 mm

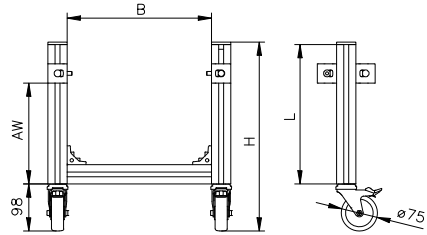

Infeed height (ELH) = 350–500 mm

Discharge End Stand B67.06.015

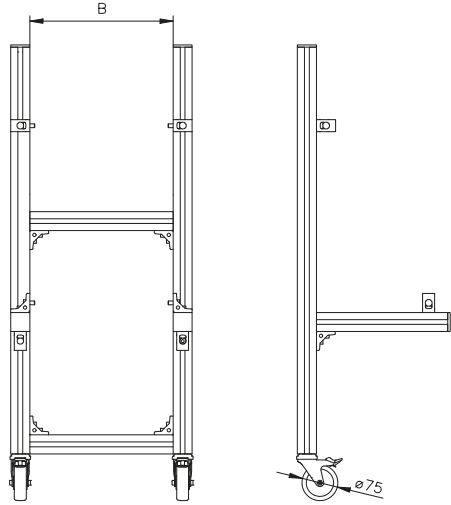

The swivel casters used have a total locking device, which guarantees a secure footing even at high transport speeds. The height and width of the stand is adapted based on the configuration; see the order example on the right.

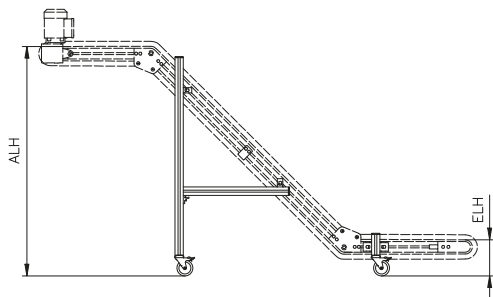

- ELH = infeed height
- ALH = discharge height
- B = conveyor width
- H = stand height
- L = length of the vertical profile
- AW = distance from the angle to the profile edge

Side Rails

Item no. B17.00.035

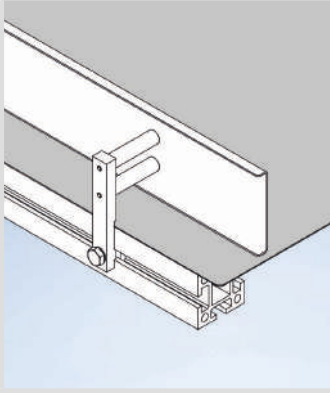

Side Rail KFG-P 2000

The side rail shown is our standard version and is available with rapid delivery times.

It provides an optimal seal between the belt and conveyor frame and prevents the loss of conveyed product and operating malfunctions.

Height 75 mm,
 others on request

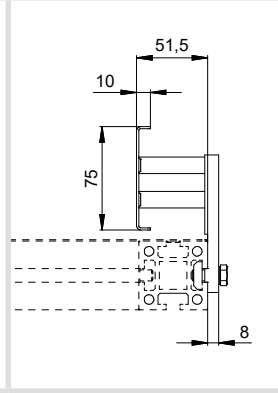

Sample order

- KFG-P 2000 type S (B20.00.010)
- Drive AF, 90° motor orientation (as displayed)
- Speed of 15 m/min
- Conveyor width B = 500 mm
- Conveyor length L1 = 500 mm;
 L2 = 1000 mm; L3 = 600 mm
- Belt incline $\alpha 1 = 60^\circ$; belt incline $\alpha 2 = 60^\circ$
- Cleat type T20 with side rail B17.00.035
- Stand, incline conveyor, type ECO
- Infeed height ELH = 200 mm
- Discharge height ALH = 1200 mm

Type designation

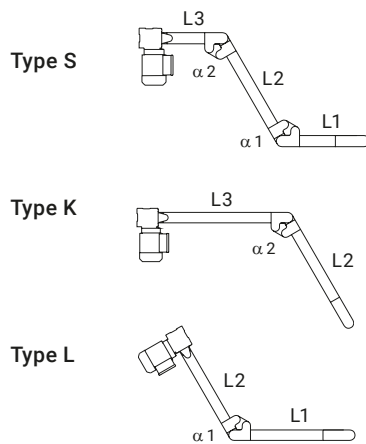

Curved Belt Conveyor KGF-P 2040



»» For horizontal material flows around curves. ««

The KGF-P 2040 conveyor system is based on Series 40 profiles and is compatible with all mk conveyor systems. The system slots running along the outer radius (10 mm slot width based on our profile technology) allow you to easily connect additional accessories such as side rails, sensors, and so on. The profile design provides a torsion-resistant structure with good load-bearing properties. The values for the total load, speeds, and so on, specified below are directly related to this design and may vary as a result.

The conveyor is equipped with a $\varnothing 20$ rolling knife edge that allows even small products to be reliably transferred to the next system. Belt tensioning is handled by an automatic tensioning device that is integrated in the tail, which keeps the conveyor's outer dimensions constant. For variants with a standard motor, the compact lower belt drive ensures that there are no obstructing edges.

Benefits of the KGF-P 2040

- Horizontal transport on a 90° and 180° curve
- Compatible with all mk conveyor systems
- $\varnothing 20$ rolling knife edge ensures reliable transport of small product
- Integrated tensioning mechanism that automatically tensions the belt
- Lower belt drive leaves no obstructing edges
- Flexible operation in reverse and accumulation modes

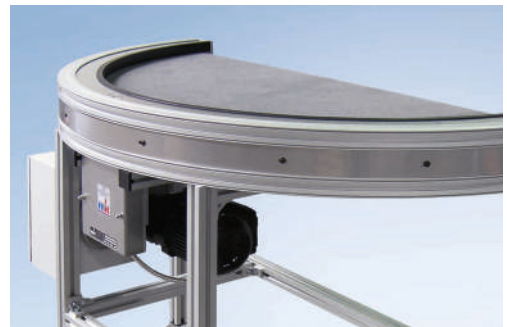
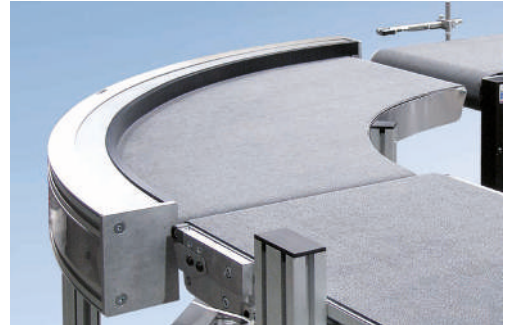

Cross Section

$B \triangleq$ conveyor width
 usable width B-100

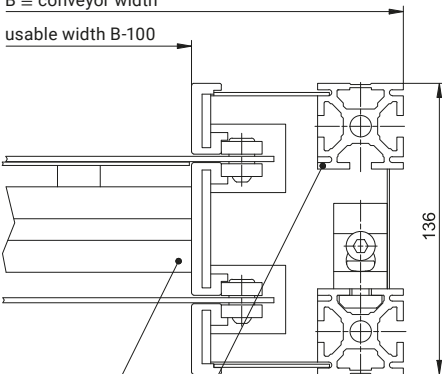

Profile mk 2040.21

Profile mk 2040.01

Properties

2

With this conveyor, mk offers the BC drive version with a usable width of 300, 400, 500 and 600 mm for 90° and 180° conveying radii. The compact conveyor frame design makes it easier to integrate the conveyor into existing systems. The $\varnothing 55$ mm driving roller ensures excellent transmission of the motor power.

B20.40.020 for 90° Curve, B20.40.021 for 180° Curve

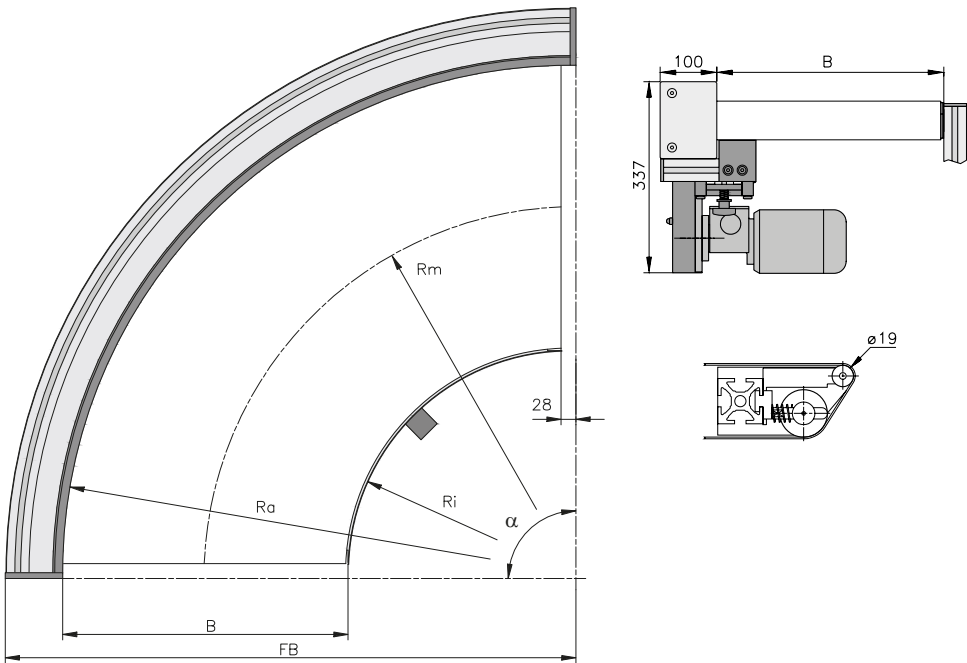

Technical data

Conveying angle	90° and 180°, others on request
Usable width B	300 with Ra=600 mm, Ri=300 mm, FB=706 400 with Ra=900 mm, Ri=500 mm, FB=1006 500 at Ra=900 mm, Ri=400 mm, FB=1006 600 at Ra=900 mm, Ri=300 mm, FB=1006
Drive location	below
Drive and speed	5 to 30 m/min in Rm, others on request
Stands	standard design or with belt replacement aid
Load capacity	depending on conveyor radius and conveyed product, up to 30 kg
Belts	

from p. 88

KGF-P 2040 Stands and Specifications

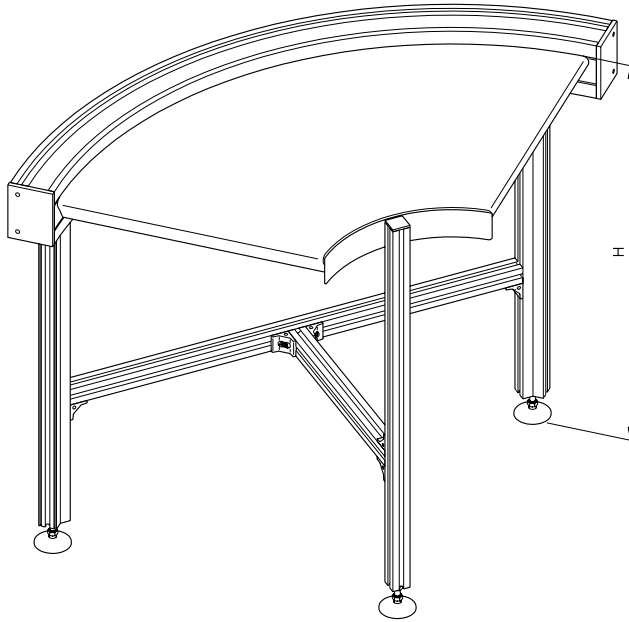

**Radius of 90° Curve Versions
 B20.40.020**

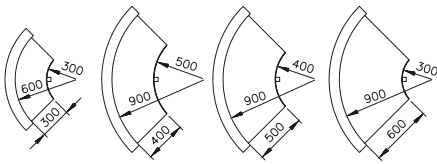

**Radius of 180° Curve Versions
 B20.40.021**

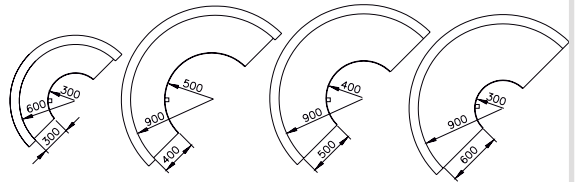

Sample order

KGF-P 2040
 Ra 900/Ri 500 version
 Speed of 15 m/min
 Conveyor width B = 400 mm
 Belt type
 Stand, with or without
 belt replacement support
 Conveyor height H = 800 mm

Type designation

Type 1

Standard stand

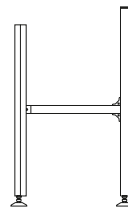

Type 2

Stand with
 belt replacement aid*

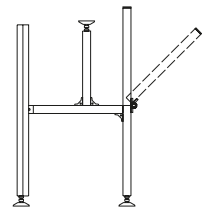

*With usable width
 B = 400 mm or wider

DGF-P 2001 Double Belt Conveyor

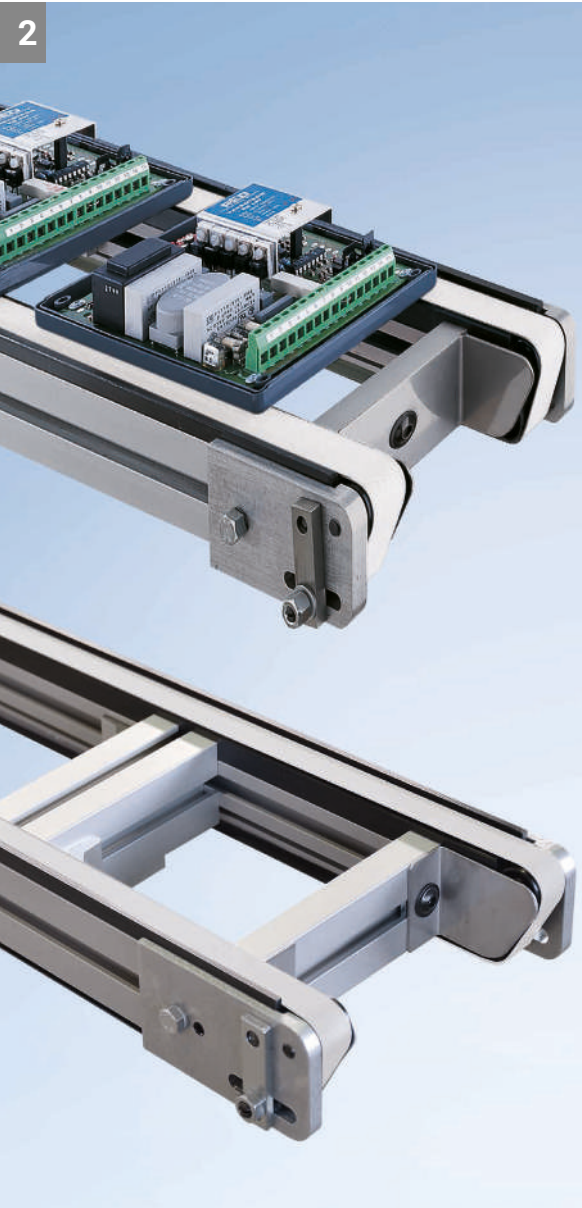

» Double-line belt conveyor system for transporting pallets. «

The DGF-P 2001 transport system is specially designed for transporting pallets. The system is often used in assembly systems, for example, in the electrical industry.

The small idler roller allows you to transport short pallets. A roller on the lower run side of the tail is responsible for the belt tension. This ensures that the conveyor maintains a fixed installation length. The belt runs entirely atop wear strips, which allows for a maximum weight of 15 kg per section.

mk delivers pallets for the DGF-P 2001 in aluminium as standard. The pallets can therefore be machined according to customer requirements.

Benefits of the DGF-P 2001

- Transporting pallets
- Very small tail allows even small pallets to be transported
- Integrated tensioning mechanism that automatically tensions the belt
- Flexible operation in reverse, accumulated and cycling mode
- Optional custom pallets

Cross Section

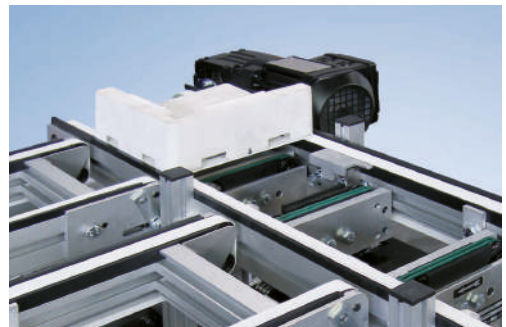
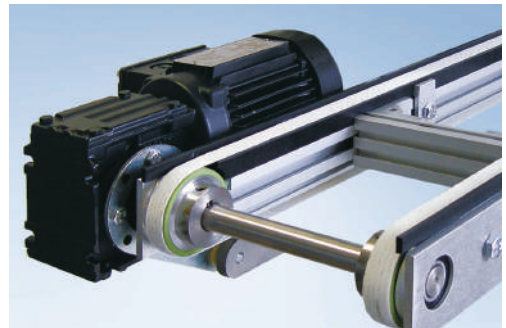
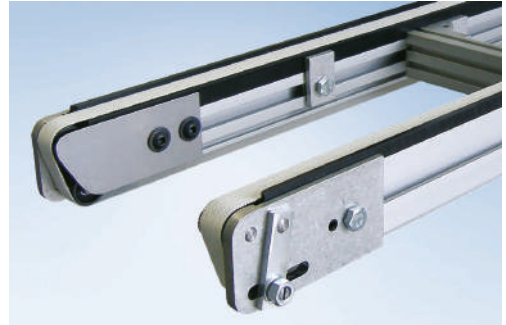
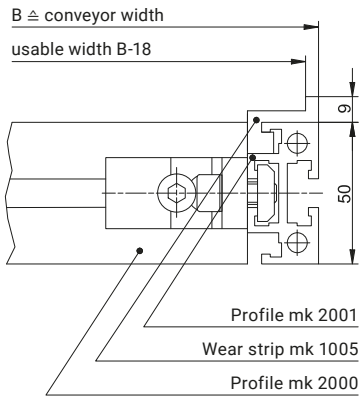

Properties

The compact conveyor frame design makes it easier to integrate the conveyor into existing systems. The $\varnothing 58$ mm driving roller ensures excellent transmission of the motor power.

B20.11.701

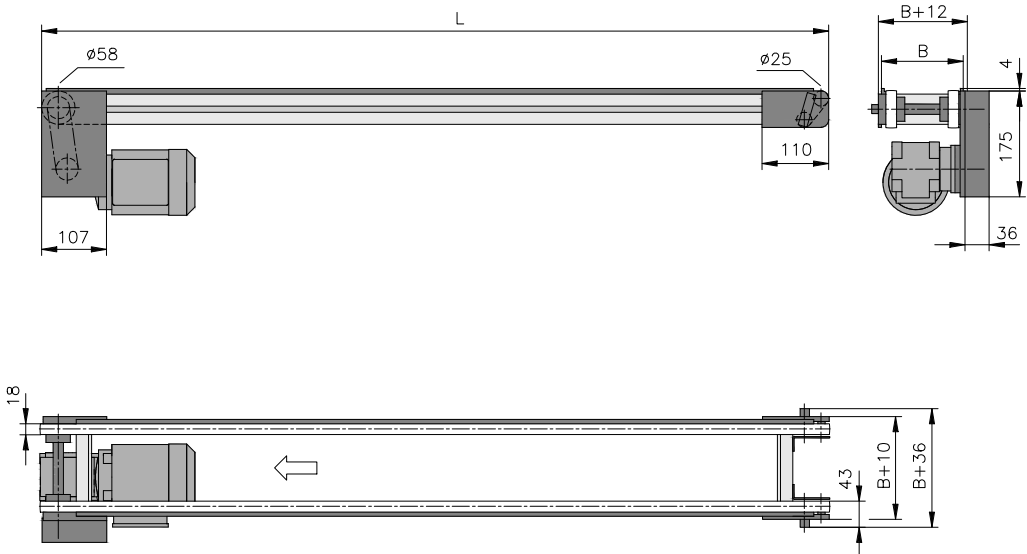

Technical data

Conveyor length L	individual from 300 to 2000 mm	
Conveyor width B	100, 125, 150, 175, 200 and 250 mm	
Belt width	18 mm (Preferred belt: GU-T0105-003BL, GU-U0306-017WE)	
Drive location	discharge end left/right, underneath, infeed on request	
Drive and speed	up to $v=15$ m/min, constant or controllable speed	
Stand and side rail		from p. 280
Standard total load	up to 15 kg, higher on request	
Standard distributed load	up to 10 kg/m, higher on request	

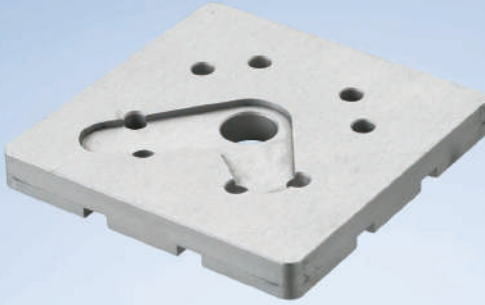

DGF-P 2001 Pallets

The pallets for the DGF-P 2001 transport system are made from aluminium (3.1325) as standard. The pallet width is always determined by the dimensions of the conveyor system (B-11 mm). The minimum length is 90 mm. Alternative pallet materials can also be used depending on the product to be transported.

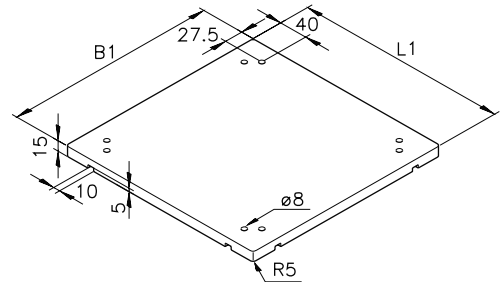
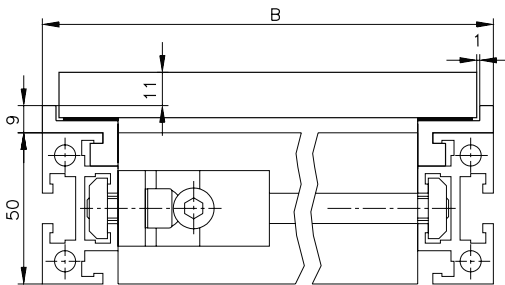

Processing

Upon request, we are happy to design pallets for your particular application or manufacture them according to your drawings.

Belts

2

General Information

For the most part, the belt types listed here meet all requirements. Other belts are available on request.

Accumulating belts are designed for long-term accumulated operation and have corresponding surface properties (friction coefficient).

Belts with limited accumulation capability are not designed for long-term accumulated operation. Relative motion is permitted, e.g. when running up against an end stop, in case of slight speed differences from one conveyor to the next, or with transverse movement of light loads (with laterally stiff belts only).

The non-accumulating belts, also known as anti-slip belts, have a structure or friction coefficient that provides high grip.

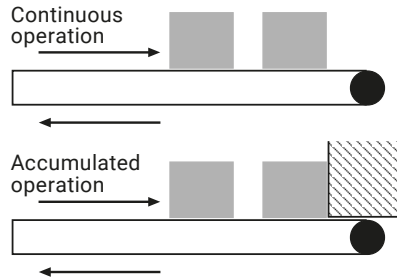

Order designation

GU -U 03 03 -001 WE

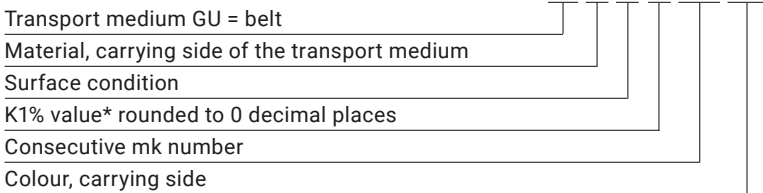





Material		Surface condition		Colour, carrying side **	
-F	Felt	01	Allows for accumulated operation	BL	Transparent
-R	Rubber (NBR)	02	Allows for restricted accumulated operation	WE	White
-T	Polyester (PET)	03	Not suitable for accumulated operation	LB	Blue
-U	Polyurethane (PU)			DG	Green
-V	Polyvinyl chloride (PVC)			SW	Black

* The K1% value is the force with which the belt is stretched by 1% per mm of width. It is an indication of the strength and therefore the load capacity of the belt.

** Depending on the batch, the colour of the belt may differ from the example in the photograph in this catalogue.

Belts

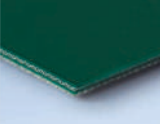
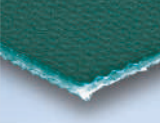
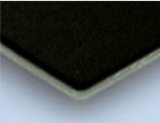
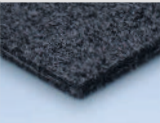



Belt group ascending in price

Item no. and designation	Allows for accumulated operation	Material	Colour	Surface	Min. ϕ of the tail	Perm. temperature	Approx. belt thickness	Properties	Belt group
K1029003 GU-T0105-003BL									
	Yes	PET	Transparent	Woven	6 mm	-10 to 70 °C	1.2 mm	Laterally stiff, antistatic, FDA-compliant, oil-resistant*	2
K1029008 GU-T0101-008BL									
	Yes	PET	Transparent	Woven	20 mm	-10 to 70 °C	1.3 mm	Antistatic, FDA compliant, suitable for curved belt conveyors	2
K1029028 GU-V0106-028DG									
	Yes	PVC	Green	Smooth	14 mm	-15 to 80 °C	1.8 mm	Laterally stiff, FDA compliant, suitable for incline conveyor	2
K1029015 GU-U0107-015DG									
	Yes	PU	Green	Smooth	40 mm	-10 to 70 °C	1.6 mm	Laterally stiff, antistatic, oil-resistant*	3
K1029010 GU-V0103-010SW									
	Yes	PVC	Black	Smooth	30 mm	-10 to 60 °C	1.8 mm	Antistatic, suitable for curved belt conveyor	2
K1029019 GU-F0106-019SW									
	Yes	Felt	Black	Smooth	30 mm	-10 to 120 °C	2.5 mm	Antistatic, suitable for curved belt conveyor	2
K1029007 GU-U0204-007WE									
	With restrictions	PU	White	Smooth	6 mm	-30 to 100 °C	1.3 mm	Laterally stiff, antistatic, FDA compliant, oil-resistant*	3
K1029050 GU-U0205-050LB									
	With restrictions	PU	Blue	Smooth	6 mm	-30 to 100 °C	1.3 mm	Laterally stiff, antistatic, FDA-compliant, oil-resistant*	3

2

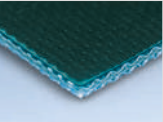
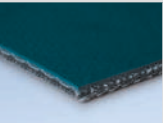

Belts

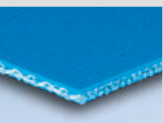
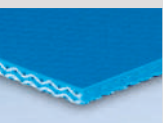
Belt group ascending in price

Item no. and designation	Allows for accumulated operation	Material	Colour	Surface	Min. ø of the tail	Perm. temperature	Approx. belt thickness	Properties	Belt group
K1029006 GU-V0203-006DG single-layer***									
	With restrictions	PVC	Green	Smooth	30 mm	-10 to 70 °C	0.8 mm	Laterally stiff, antistatic	1
K1029011 GU-U0205-011DG									
	With restrictions	PU	Green	Smooth	50 mm	-15 to 80 °C	1.6 mm	Laterally stiff, antistatic, FDA-compliant, oil-resistant*	4
K1029029 GU-U0310-029DG									
	No	PU	Green	Smooth	50 mm	-30 to 90 °C	2.4 mm	Laterally stiff, FDA compliant, suitable for incline conveyor, oil-resistant*	4
K1029001 GU-U0302-001WE single-layer***									
	No	PU	White	Smooth	6 mm	-20 to 70 °C	0.7 mm	Antistatic, FDA-compliant, oil-resistant*	1
K1029004 GU-U0305-004WE									
	No	PU	White	Smooth	6 mm	-30 to 80 °C	1.2 mm	Laterally stiff, antistatic, FDA-compliant, oil-resistant*	3
K1029017 GU-U0306-017WE									
	No	PU	White	Smooth	10 mm	-30 to 80 °C	1.4 mm	Laterally stiff, antistatic, FDA-compliant, oil-resistant*	3
K1029030 GU-U0308-030LB									
	No	PU	Blue	Smooth	6 mm	-30 to 100 °C	1.4 mm	Laterally stiff, antistatic, FDA-compliant, oil-resistant*	3
K1029024 GU-U0305-024LB									
	No	PU	Blue	Smooth	6 mm	-30 to 100 °C	1.5 mm	Laterally stiff, antistatic, FDA-compliant, oil-resistant*	3

Belts

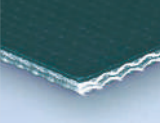
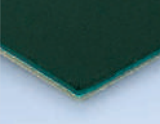
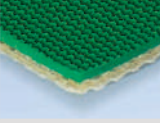
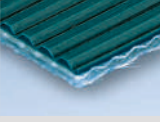
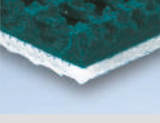
Belt group ascending in price

Item no. and designation	Allows for accumulated operation	Material	Colour	Surface	Min. ø of the tail	Perm. temperature	Approx. belt thickness	Properties	Belt group
K1029012 GU-U0306-012DG									
	No	PU	Green	Smooth	25 mm	-30 to 100 °C	1.4 mm	Laterally stiff, antistatic, FDA-compliant, oil-resistant*	3
K1029009 GU-V0303-009DG									
	No	PVC	Green	Smooth	25 mm	-10 to 70 °C	1.8 mm	Antistatic, suitable for curved belt conveyor	2
K1029013 GU-V0307-013DG									
	No	PVC	Green	Smooth	40 mm	-10 to 60 °C	2.0 mm	Laterally stiff, antistatic	2
K1029005 GU-R0303-005DG									
	No	NBR	Green	Woven	30 mm	0 to 80 °C	1.5 mm	Antistatic, oil-resistant*, cut-proof	3
K1029016 GU-U0305-016DG									
	No	PU	Green	Structured	40 mm	-30 to 80 °C	1.9 mm	Antistatic, oil-resistant*	4
K1029014 GU-V0306-014DG									
	No	PVC	Green	Structured	50 mm	-10 to 60 °C	4.9 mm	Laterally stiff, antistatic	3
K1029018 GU-V0307-018SW									
	No	PVC	Black	Structured	40 mm	-10 to 60 °C	2.2 mm	Laterally stiff, antistatic	2

* The belt's oil resistance may need to be tested based on the type of oil used.

** Cut-proof belts ensure a longer service life when transporting sharp products such as stamped parts.

*** Single-layer belts are less robust and therefore must not be as strongly pre-tensioned.

Cleats and Side Walls

2

When selecting a cleat profile, please note that the cleat must be of the same material as the belt. Interrupted transverse cleats are possible, as are combinations of longitudinal and transverse cleats. The distance from the cleats to the edge of the belt must be at least 2 mm.

The bonding points on the cleats generally have more limited temperature range than the belt and clean material itself.

Longitudinal cleats, internal (running side) are a belt guide option and are usually used where lateral forces act on the belt. In the area of the longitudinal cleats, the belt may be uneven.

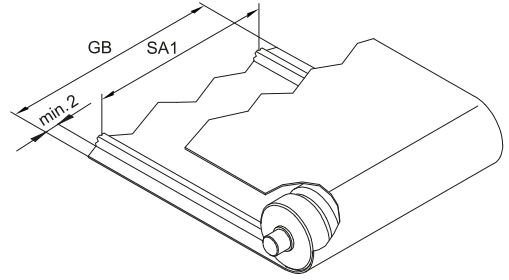

Side walls, external (carrying side) can be used instead of side rails and are often employed in incline conveyors.

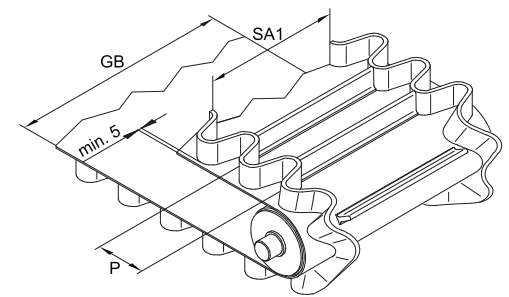

Transverse cleats (carrying side) serve as the carrying mechanism for the conveyed product, especially in inclined conveyors.

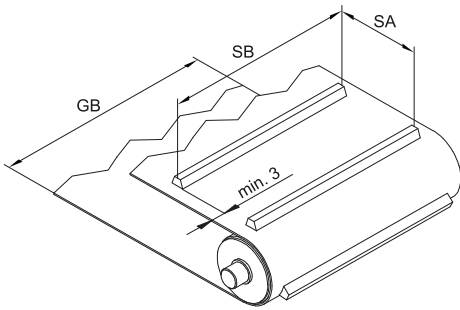



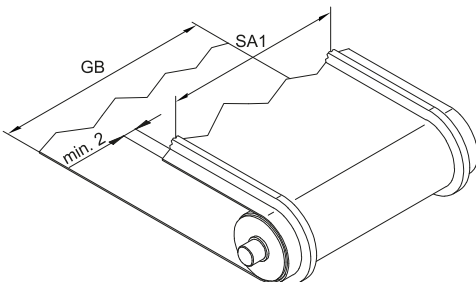



Longitudinal cleats, external (carrying side) are used to guide the belt on concave tracks (for example, on incline conveyors).



Cleats and Side Walls

2

Longitudinal Cleats (can also be used as lateral cleats)

Designation	Material/colour				Min. SA/SA1* [mm]	Weight [g/m]	Min. ϕ of idler roller [mm]		
	PVC		PU				Longitudinal cleats Running side	Longitudinal cleats Carrying side	Transverse cleats Carrying side
	Green	White	Trans- parent	Green					
K6 	•	•	•		30	25	40	30	30
K10** 	•	•	•	•	30	60	70	60	50
K13 	•	•	•		30	100	90	60	80
K15 	•		•		30	120	90	60	90
K17 	•	•	•		30	180	90	90	100
F20/3 	•	•			30	75	70	50	70
F30/8 	•	•			45	290	120	90	120



*SA1 = minimum distance between longitudinal cleats/SA = minimum distance between transverse cleats

**This cleat must be used for the belt guide on the carrying side for the incline conveyor.

Cleats and Side Walls

2

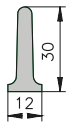
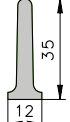
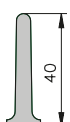
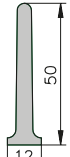
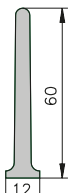
Transverse Cleats

Designation	Min. SA*	Material/colour				Weight [g/m]	Min. ϕ of idler roller [mm] Transverse cleats carrying side
		PVC		PU			
		Green	White	Green	White		
T20U 	40			•	•	140	50
T30U 	40			•	•	180	50
T35U 	40			•	•	200	50
T40U 	40			•	•	220	50
T50U 	40			•	•	250	50
T60U 	40			•	•	280	50
T20 	55	•	•			160	90

Cleats and Side Walls

2

Transverse Cleats

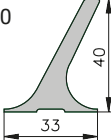
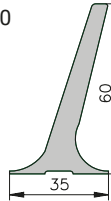
Designation	Min. SA*	Material/colour				Weight [g/m]	Min. ϕ of idler roller [mm] Transverse cleats, carrying side
		PVC		PU			
		Green	White	Green	White		
L40 	55	•	•			140	85
L60 	55	•	•			180	85

*SA = minimum distance between transverse cleats

Side Walls

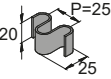
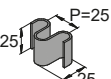
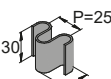
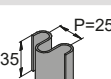
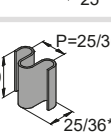
Designation	Material/colour						Min. ϕ of idler roller [mm] (\cong 2 x side wall height)
	Green	PVC White	Blue	Green	PU White	Blue	
WK20 	•	•	•	•	•	•	40
WK25 	•	•	•	•	•	•	50
WK30 	•	•	•	•	•	•	60
WK35 	•	•	•	•	•	•	70
WK40 	•	•	•	•	•	•	80

The minimum distance from the side wall to the edge of the belt is 5 mm. Min. SA1 = 60; min. A = 5
*Varies based on the version

Application Examples

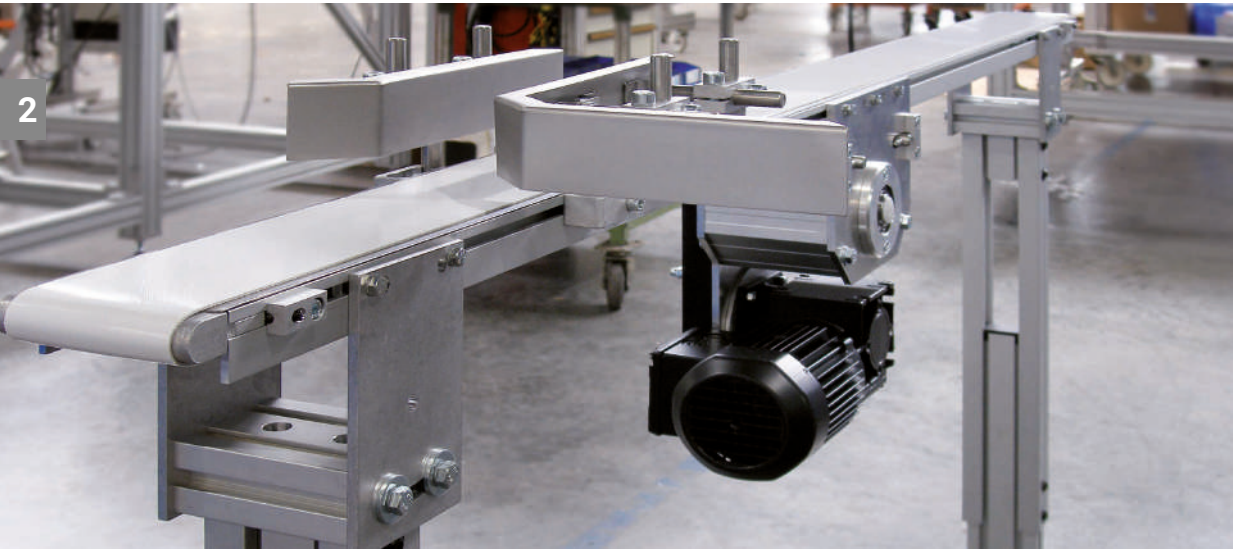

GUF-P MINI with lower belt drive BC for integration into an existing system with adjustable side rail



GUF-P MINI with head drive AF as incline conveyor type L, for transporting parts to a lower transport level



GUF-P MINI with lower belt drive BC as special configuration with 5 conveying lines.
 The inner conveying lines can be moved manually and are guided by guide rods



GUF-P MINI with lower belt drive BC as inclined conveyor, stand system 53.12

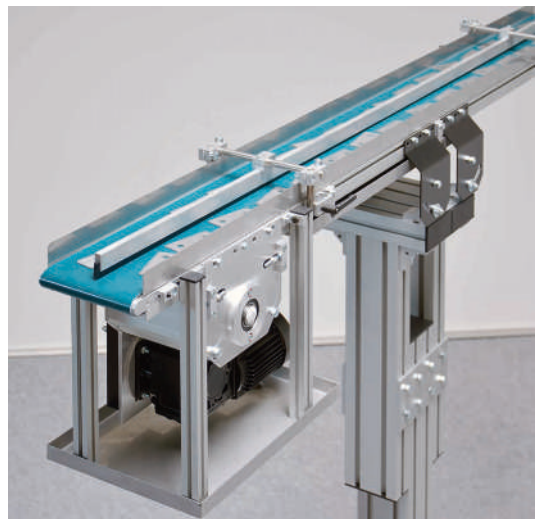

GUF-P MINI with single-belt stand and drip pan below the motor for slightly oily stamped parts

Application Examples



2
GUF-P 2000 with AC head drive and multi-track side rail as separator conveyor, complete with drip pan



Telescopic GUF-P 2000, infeed can be extended using recirculating ball bearing guide



Mobile GUF-P 2000 with removal chute with variable incline angle



GUF-P 2000 with mechanism for folding and setting up paper bags upstream of the filling process

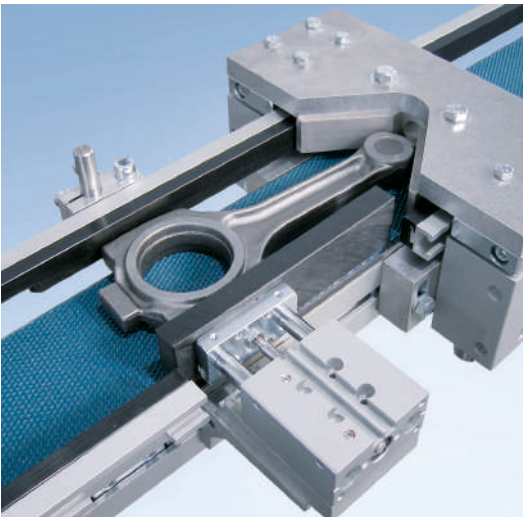

GUF-P 2000 for connecting rods with pneumatic positioning station

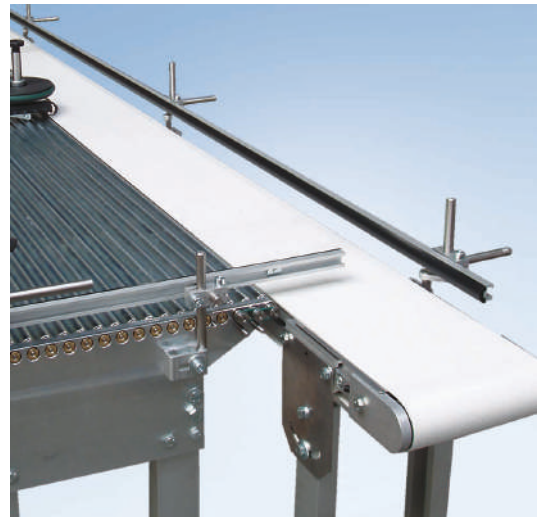

GUF-P 2000 as cross conveyor and separator downstream from a cooling line

Application Examples



GUF-P 2000 can be moved on track roller assembly, with manual swivelling belt infeed



GUF-P 2000 with head drive AC with wire mesh belt for conveyed goods at up to 150° C

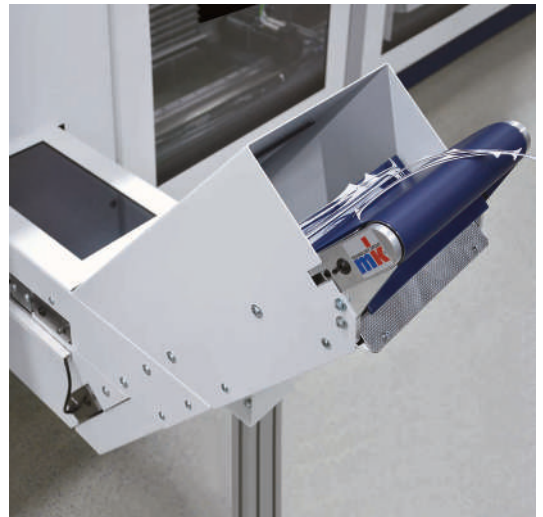

Belt conveyor GUF-P 2045 with low installation height integrated into blister packing system



GUF-P 2000 as cross conveyor and separator



GUF-P 2000 with integrated adjusting unit (VST 2011) for height adjustment of the wiper brushes



GUF-P 2000 as a conveyor belt for serial packers with a heat sealing station for producing custom shipping bags



GUF-P 2000 with rolling knife edge and separator conveyor with head drive AF

Application Examples

2



Combination of INOX belt conveyor and angled belt conveyor for transport of praline balls with granulate



INOX vacuum belt conveyor with connections for vacuum pump

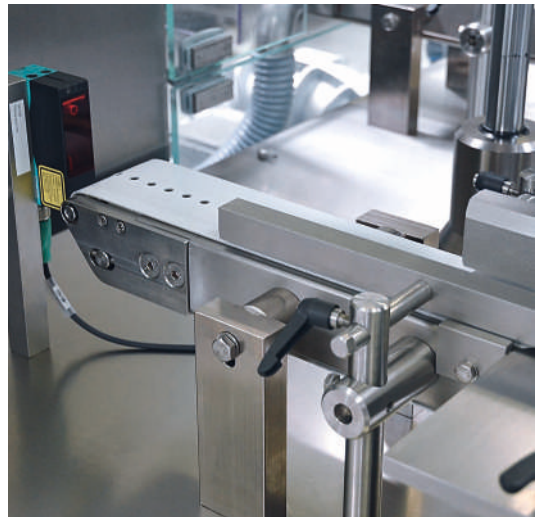

INOX vacuum belt conveyor with custom side rail



INOX belt conveyor with rolling blade edge for the transfer/handling of small transport goods

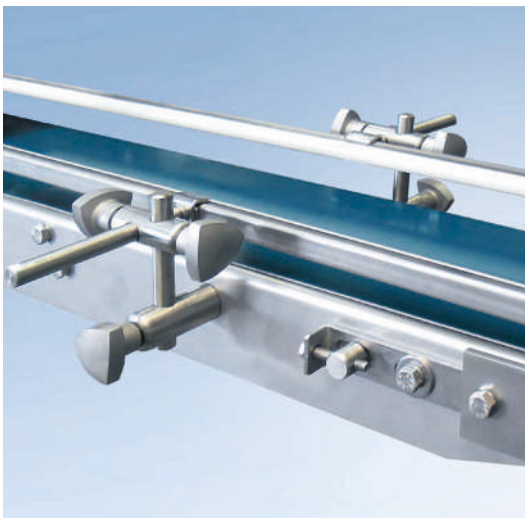

INOX belt conveyor with adjustable side rail



INOX belt conveyor with head drive AF

Application Examples

2



GUF-P 2041 with protective tunnel as discharge belt for rear axle parts

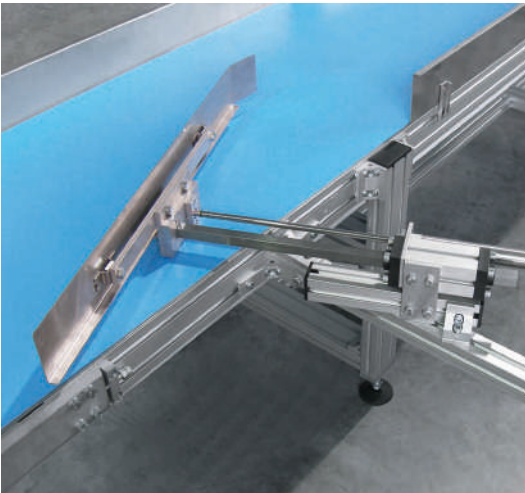

GUF-P 2041 with pneumatic diverter

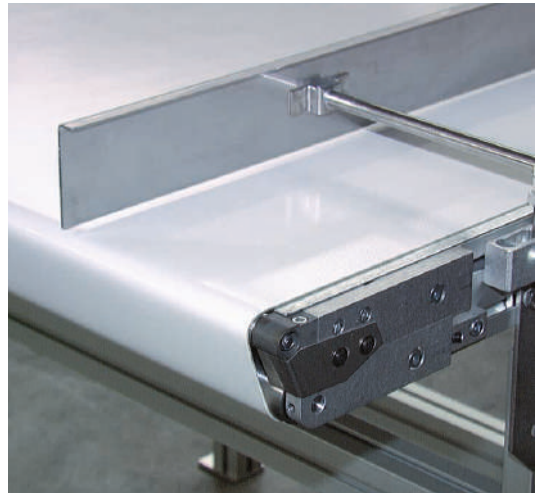

GUF-P 2041 with adjustable side rail



GUF-P 2041 with lower belt drive BC; the height of the frame can be adjusted using a hydraulic pump



GUF-P 2041 with head drive AC and 90 watt fans in the conveyor frame, reglomat mounted on top of the conveyor frame



Two GUF-P 2041 units in tandem arrangement with mobile stand system for mobile dual system supply

Application Examples



GUF-P 2041 with a special design as a vacuum conveyor for offset pressure plates



GUF-P 2041, head drive AC with support pan and transverse cleats

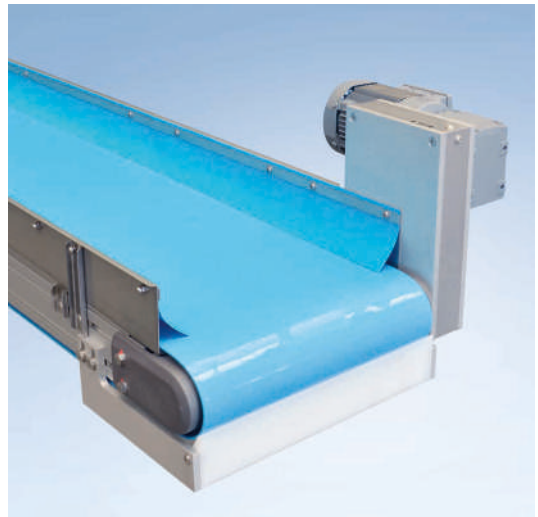

GUF-P 2041 upward offset AC head drive with belt slide bed on both sides and front side wiper on the discharge



Circulation system for manually sorting laundry based on GUF-P 2041 and GUF-P 2000 conveyors with AC head drive



C-frame with recirculating ball bearing guides, each with 2 roller carriages for lifting or lowering the GUF-P 2004 conveyors



GUF-P 2004 with head drive AS fitted laterally on the outside as a two-level conveyor with drip pans on a shared base frame

Application Examples

2

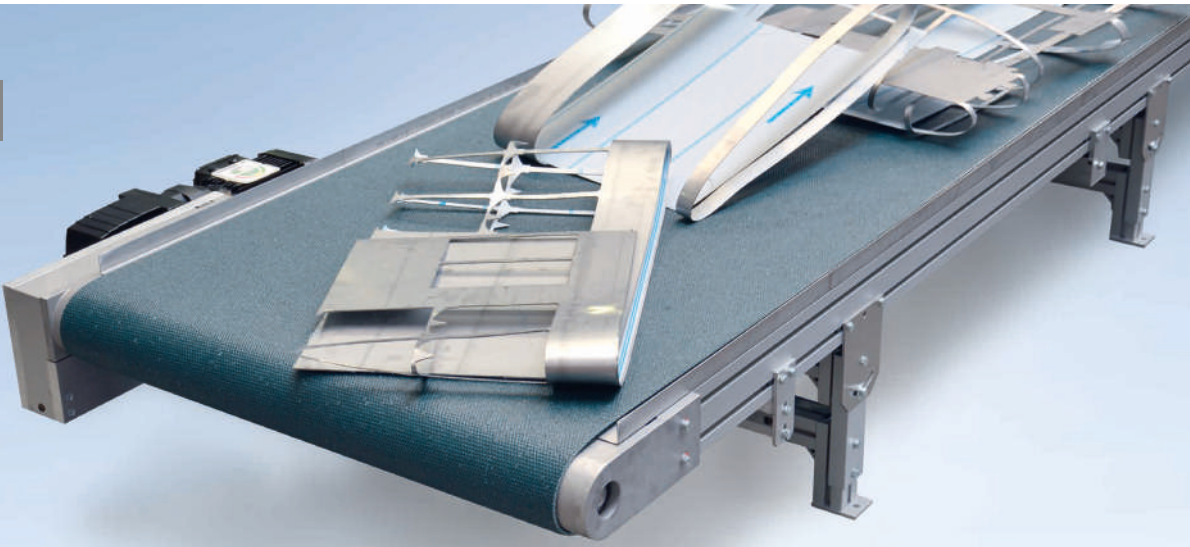

GUF-P 2004 with lateral outer AS head drive and robust special belt for punch scrap

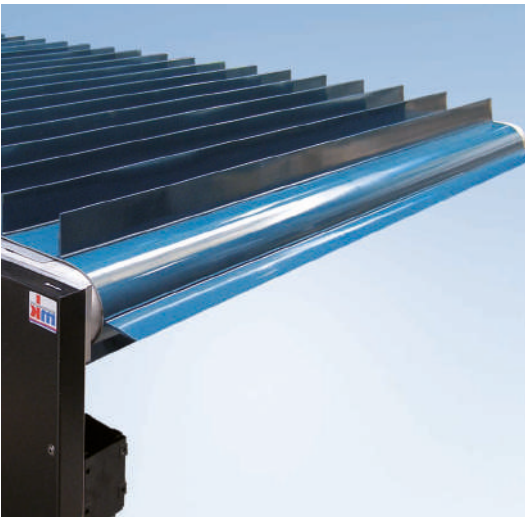

GUF-P 2004 with head drive AC and transverse cleats



Belt conveyor combination of GUF-P 2004 with drum motor CA and dual line KTF-P 2004



2

GU-F-P 2004 designed with maximum width $B=2$ m



GU-F-P 2004 with divided upper run and lower run



GU-F-P 2004 can serve as a transport guide for reversing vehicles; the carrying side of the belt is divided into numbered sections

Application Examples

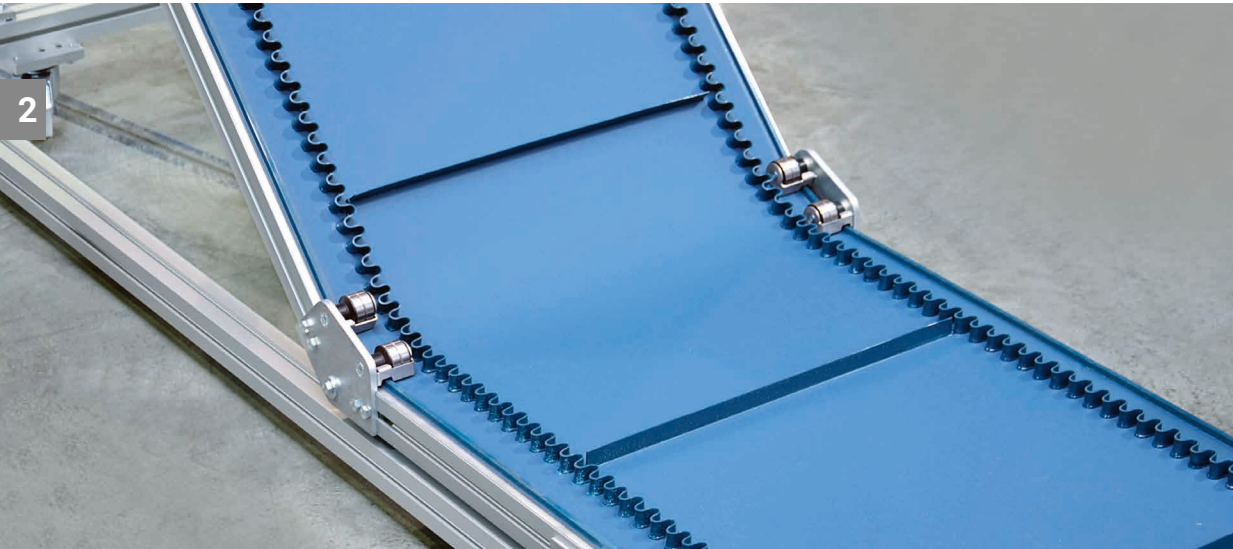

KFG-P 2000 with side wall for lateral boundaries and transverse cleats



KFG-P 2000 with head drive AU and 45° incline



KFG-P 2000 ECO with head drive AF and 60° incline variant B3 (B20.00.015-B3)



2

KFG-P 2000 with head drive AF and transverse cleats



Mobile KFG-P 2000, type K with side rail SF 9.1 (VA sheet steel, tilted) and transfer hopper at the beginning of the conveyor, including controller



KFG-P 2000 with head drive AC with side rail SF 8.1, belt guide on both sides via longitudinal cleats K10

Application Examples

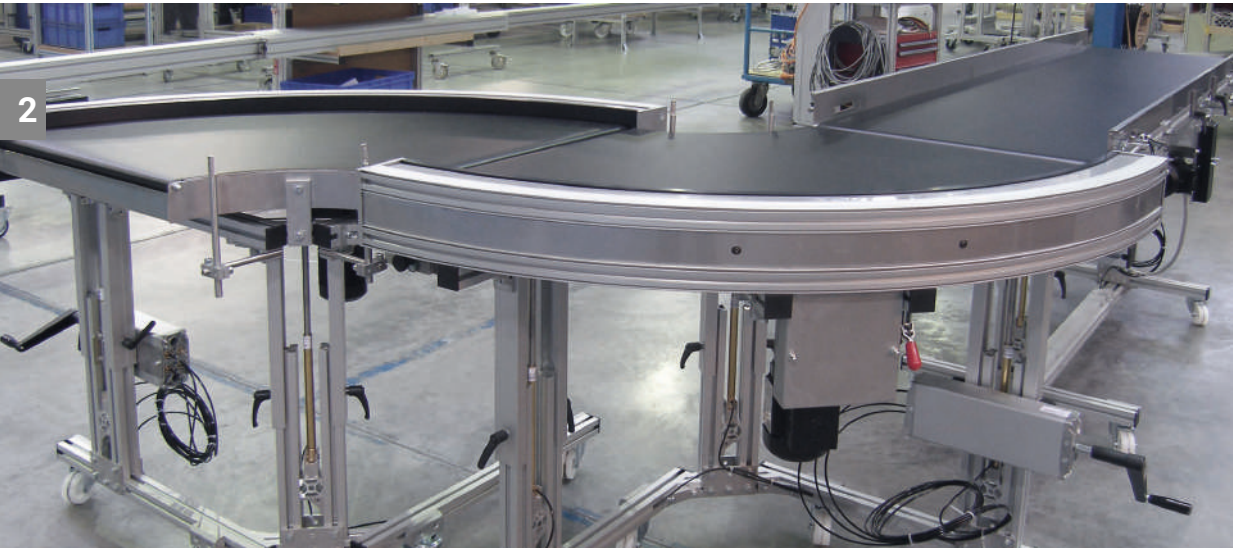

KGF-P 2040 with lower belt drive BI and hydraulic adjustment of the stand height using a hand crank



Combination of 90° and 180° KGF-P 2040 curved belt conveyors with lower belt drive BI, reversible

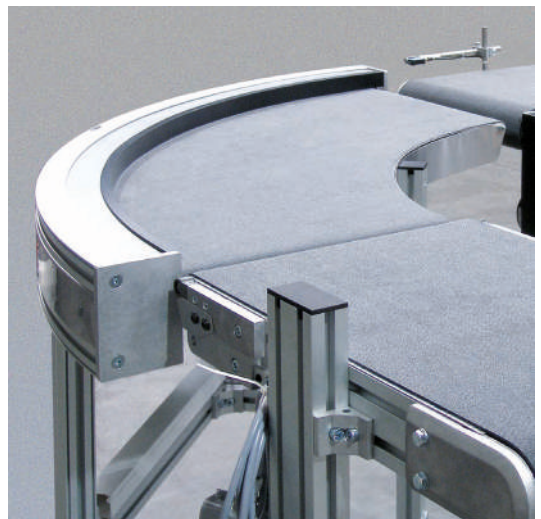

Transfer between KGF-P 2040 and GUF-P 2041 with rolling knife edge for conveyed products starting at a length of 50 mm

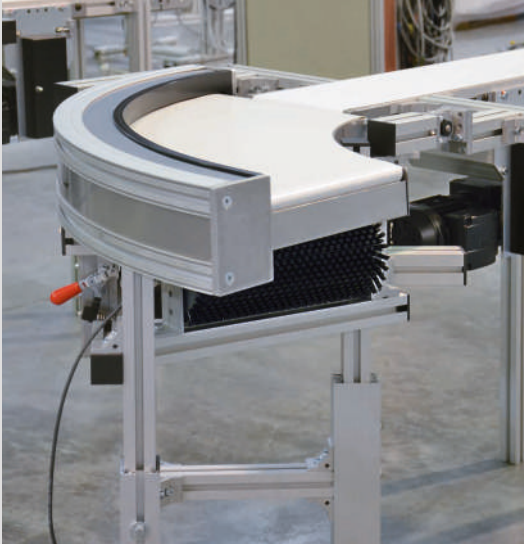

KGF-P 2040 with lower belt drive BI and rotating wiper brush underneath the conveyor (return)



2

180° KGF-P 2040 with side rail



KGF-P 2040 with rollers for transfers to the belt conveyor without a knife edge



180° KGF-P 2040 with fully closed cover and 0 mm inner radius

Application Examples



DGF-P 2001 with lower belt drive BC

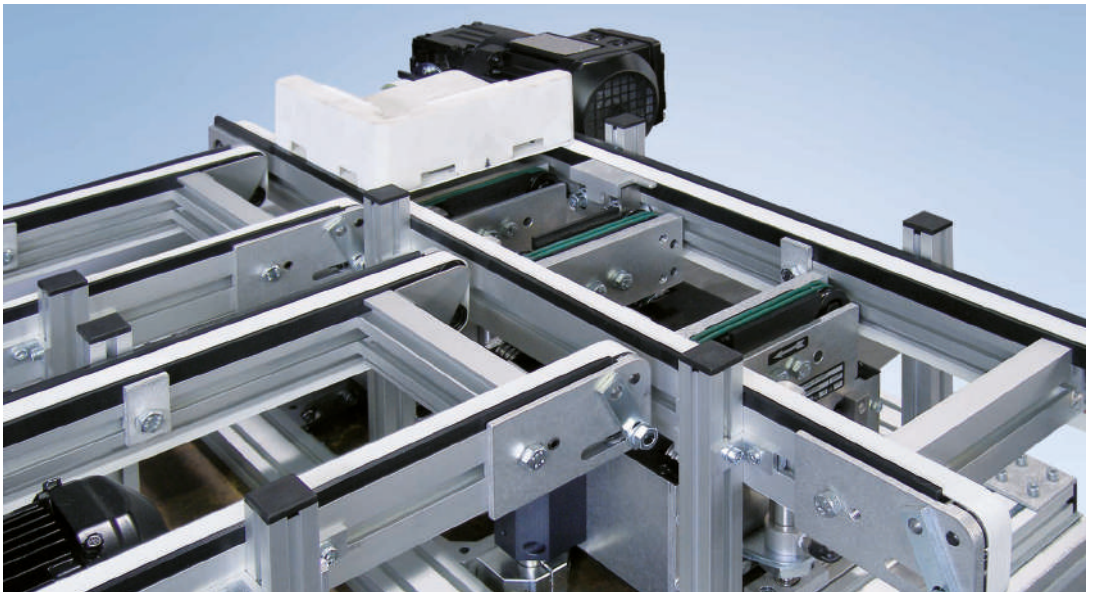

Pallet circulation from the conveyor DGF-P 2001, integrated lift-and-transfer conveyor with round belt or separating pallets

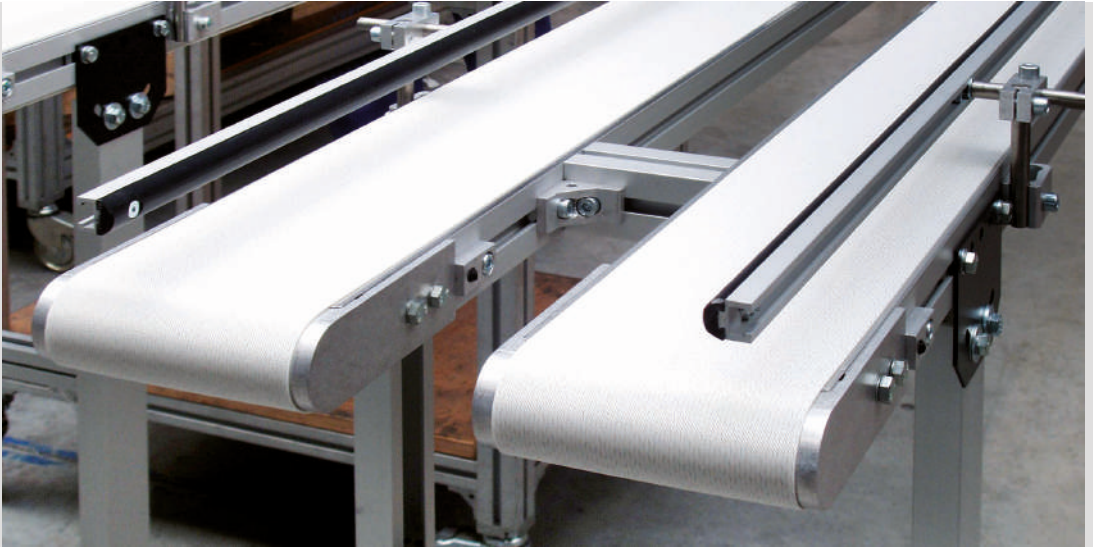

2

GUF-P 2000 double-line conveyor; the clearance between the belts allows for access from below

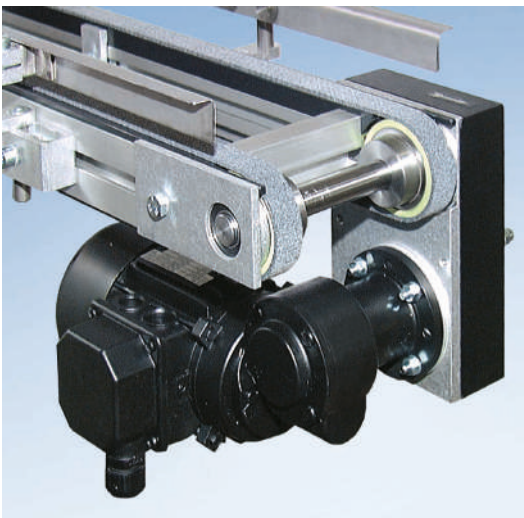

DGF-P 2001 with side rail for over-wide conveyed goods



DGF-P 2001 with lower belt drive BC

Chapter 3 Modular Belt Conveyors

3



Selecting a Modular Belt Conveyor

118

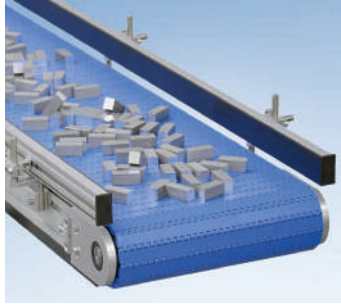

Modular Belt Conveyor MBF-P 2040

120

Head Drives

122



Incline Conveyor Modular Belt KFM-P 2040

124

Head Drives

126

Stands

128



Curved Modular Belt Conveyor KMF-P 2040

130

Head Drives

134



Incline Conveyor Hinged Plate Belt KFS-P 2040.86

136

Head Drives

138

Stands

140

Side Rails

141

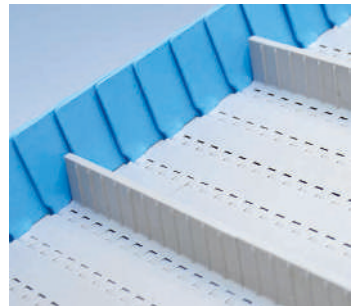

Modular Belts

For MBF-P 2040

142

For KMF-P 2040

144

For KFS-P 2040.86

145

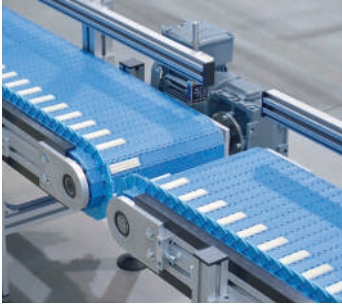

Application Examples 146

Selecting a Modular Belt Conveyor

Dimensions – Technical Data

Conveyor system	Conveyor widths [mm]	Conveyor lengths [mm]	Total load* as standard, up to [kg]	Speed up to [m/min]	ø of tails [mm]	Reverse operation	Accumulated operation	Cycling operation
Modular Belt Conveyors								
MBF-P 2040	approx. 200–1000	475–10000	250	30	approx. 100		•	•
Incline conveyor modular belt								
KFM-P 2040	approx. 200–1000	1000–4000	100	30	approx. 100			•
Incline conveyor, hinged plate belt								
KFS-P 2040.86	210–710	1400–10000	150	12	150			•

*Maximum load that is transported by the system in question with a standard configuration and for a standard application. The permissible load depends on the width, number of teeth, drive sprocket wheels, chain type, load distribution, operating mode and environmental influences.

System Selection

... based on the Load, Conveyor Width and Chain Series

The diagram can be used as a basis for determining the permissible total load based on the conveyor width and chain series. For the plastic modular belts, a coefficient of friction of $\mu=0.3$ is assumed. For the steel chain (hinged plate belt), a coefficient of friction of $\mu=0.15$ is assumed.

For accumulated operation, the mass that accumulates must also be taken into account with $\mu=0.3$ for the total load. Theoretically, this means that the mass in accumulated operation must be doubled (200 kg in accumulated operation equals 400 kg in continuous operation). The standard application with lateral cleats, particularly with incline conveyors, does not allow accumulated operation.

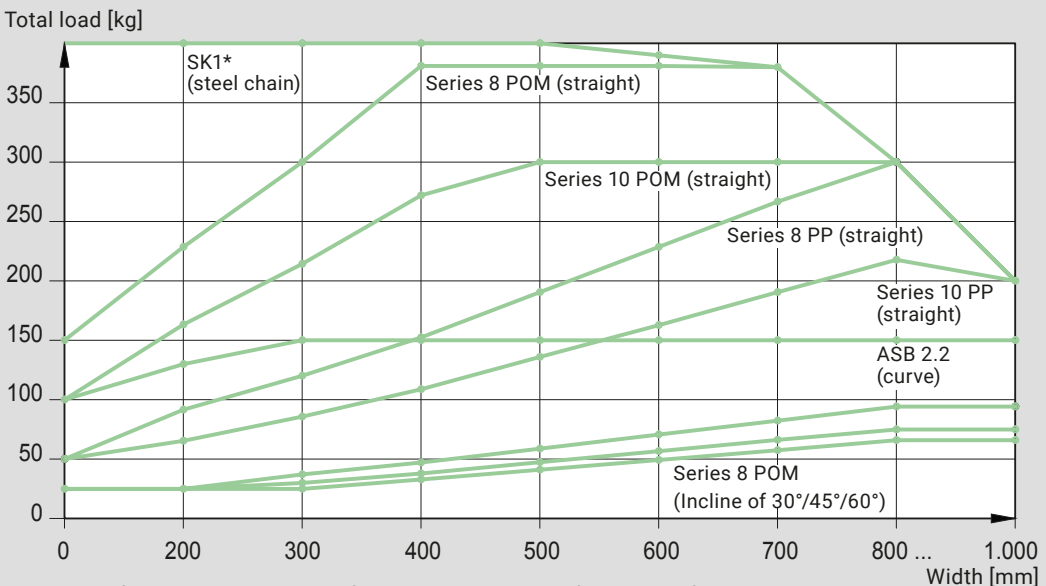

*The total load for the steel chain is the sum of the payload and the weight of the chain itself.

Application Options

Due to their positive locking drive in the side rail, modular conveyors are recommended where a belt is not an option due to slip, an unfavourable length-width ratio or transverse forces. The low-maintenance plastic modular belts in Series 8 and 10 (straight) and ASB 2.2 (curve) are standard versions.

Upon request, we can provide a design with reinforced bearings, supplemental supports of the drive shaft and an appropriate number of additional sprockets to utilise the full performance capacity of the chain and, following testing and coordination, enable widths of up to 2 m.

The hinged plate belt for the incline conveyor is equipped with a steel chain that makes it suitable for harsh environmental conditions and for transporting products such as stamped, cast, forged or wooden pieces. It is particularly suitable for conveying hot goods up to 200° C and can also be configured as a straight section (type G).

On request, transverse cleats can be screwed or welded on. Stainless steel or perforated variants of the chain are available. Due to the gap of 1 to 3 mm between the side rail and chain, this system is not suitable for pointed stamping scraps or metal chips.

Modular Belts

Series 8 is characterised by its robustness and is used in industrial applications in particular. Series 10 is intended for transporting lightweight to medium-weight products in sanitary environments, such as those found in the food industry and the pharmaceutical sector. The module geometry and the sprocket wheels were therefore designed to ensure easy cleaning, to eliminate cavities and hollow spaces and to allow for limited self-cleaning of the gaps.

Transverse cleats up to 75 mm in height and side plates up to 100 mm in height are available for both series. This eliminates the need for a complex side rail, as well as the associated problems arising from gaps and from relative motion between the chain and side rail.

For the permissible tensile load, a safety factor of three relative to the permissible tensile loads of the chain was included in the calculation to ensure reliable durability. At a length of 3 metres, the usual chain slack can be dispensed with, which allows for restricted reversing operations. At lengths of more than 3 metres or under heavy loads, the conveyor is run with a balance option.

The chain for curves (ASB 2.2) is highly resistant to wear and abrasion, making it suitable for high temperatures, contact with chemicals or food, etc.

Chain material

The Series 8 chain made from impact-resistant, affordable polypropylene (PP) is the standard for industrial applications. Series 10 is made from polyethylene (PE) for applications in the food industry.

For especially demanding requirements regarding max. load and/or cut resistance, we recommend polyoxymethylene (POM, POM-CR). This material can even handle the occasional impact from product landing forcefully on the chain or the transverse cleats.

Modular Belt Conveyor MBF-P 2040

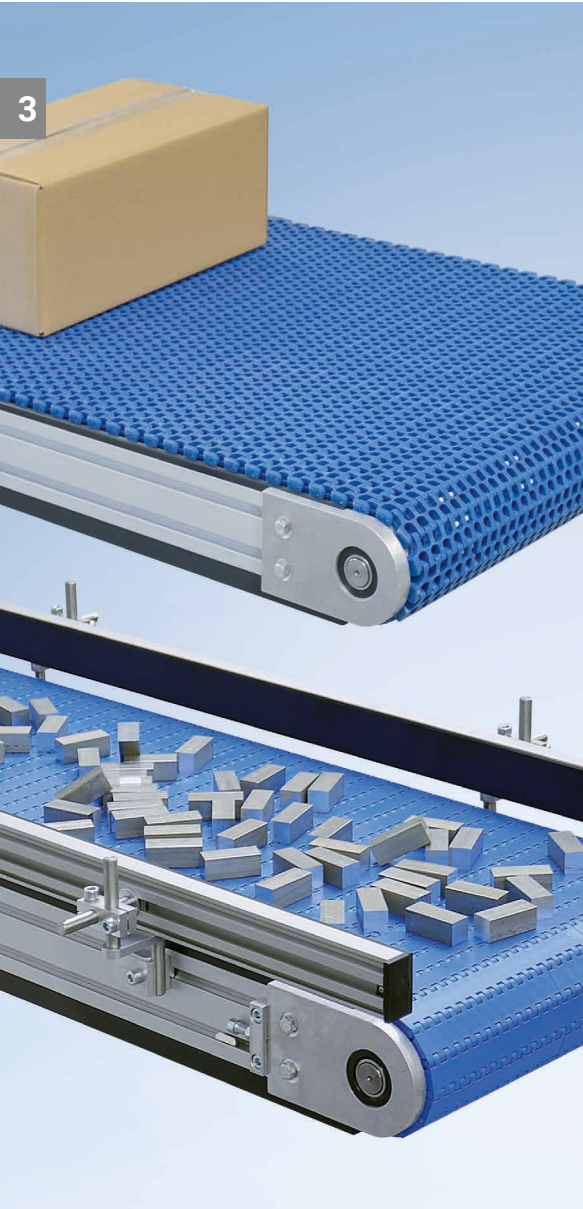

» Straight version for flexible combination with curved and inclined tracks. «

The positive drive mechanism on the conveyor system MBF-P 2040 with modular belt allows it to convey high loads even with narrower conveyor widths. The belt guide ensures that there is no lateral movement. It also allows conveyed products to be moved diagonally.

The material of the modular belt offers a high level of wear-resistance and abrasion resistance. The conveyor system offers various chain materials to make it suitable for food, suitable for high temperatures or resistant to chemicals. Accessories such as side plates and transverse cleat profiles are also included in the product range.

Maintenance work such as tensioning the belt or replacing individual elements can be carried out quickly and easily.

Benefits of the MBF-P 2040

- High load capacities available
- Positive drive mechanism eliminates slippage and makes it suitable for wet applications
- Stable chain travel regardless of the length/width ratio
- Maximum usable width with low total width
- Lateral movement of conveyed products
- Belt is guided to eliminate lateral deviation
- Chain material is highly resistant to wear and abrasion, making it suitable for high temperatures, contact with chemicals or food, etc.

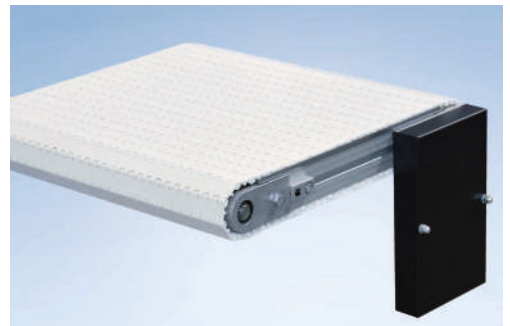
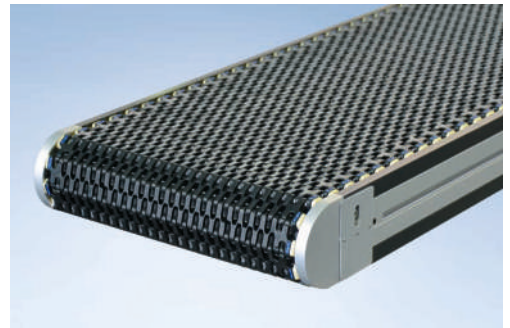
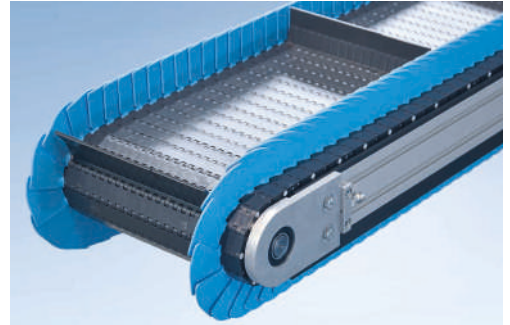

Cross Section*

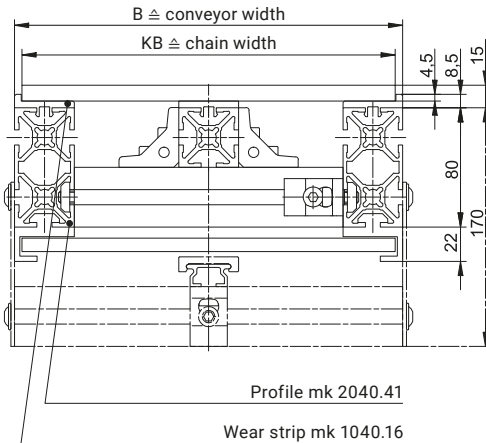
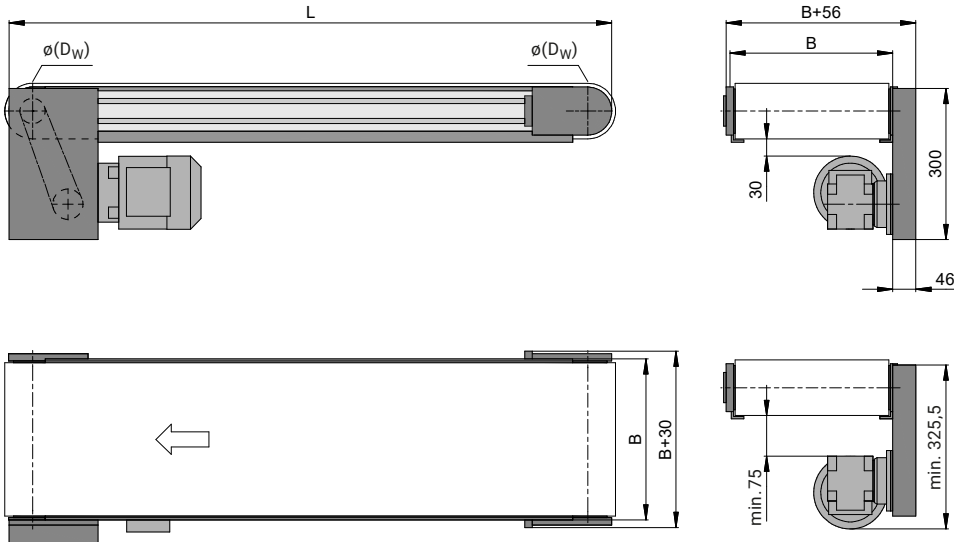

*Diagram includes a modular belt support in the lower run (dashed line). Only necessary with $B > 700$ mm.

Properties

The compact conveyor frame design makes it easier to integrate the conveyor into existing systems. The sprocket wheel with the positive-locked connection to the modular belt ensures excellent transmission of the motor power. At lengths of up to three metres, the chain does not sag but the belt still runs quietly. With lengths of around three metres or more, there is chain sagging on the drive end, which is enclosed by a protective box. This results in an additional obstructing edge.

B20.40.806



Technical data

Conveyor length L	individual from 475 to 10000 mm	
Conveyor width B	approx. 200–1000 mm depending on the chain type	p. 142
Drive location	left/right underneath	
Drive and speed	up to 30 m/min	p. 12
Stands		from p. 280
Standard total load	up to 250 kg	p. 118
Standard distributed load	up to 75 kg	p. 118
Pitch diameter (DP)	chain S8=99.7 mm; chain S10=98 mm	



Properties

The drive located laterally on the outside allows the total height of the conveyor to be restricted to a minimum. The sprocket wheel with the positive-locked connection to the modular belt ensures excellent transmission of the motor power. With lengths of up to three metres, the chain does not sag but the belt still runs quietly. With lengths of around three metres or more, there is chain sagging on the drive end, which is enclosed by a protective box. This results in an additional obstructing edge.

B20.40.807

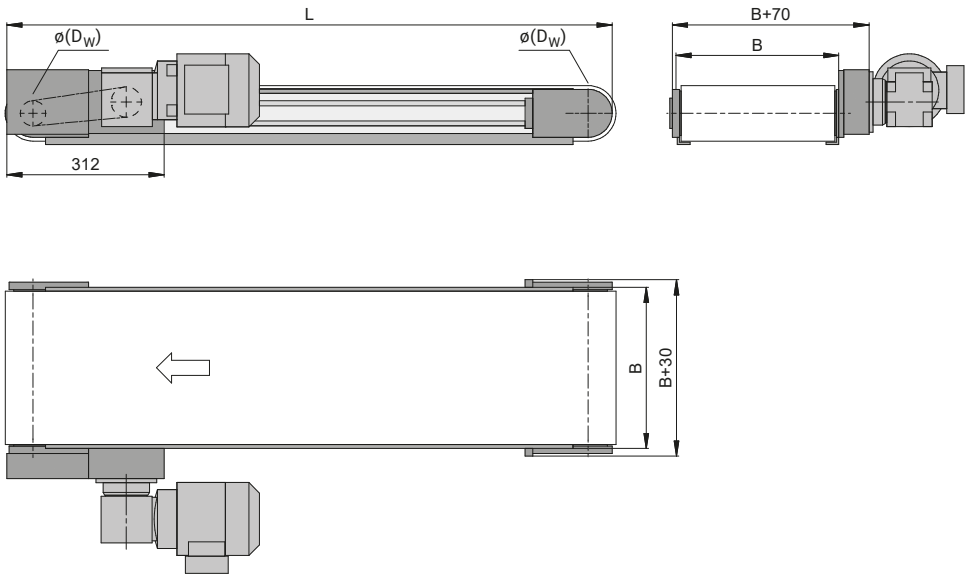

Technical data

Conveyor length L	individual from 610 to 10000 mm	
Conveyor width B	approx. 200–1000 mm depending on the chain type	p. 142
Drive location	left/right underneath	
Drive and speed	up to 30 m/min	p. 12
Stands		from p. 280
Standard total load	up to 250 kg	p. 118
Standard distributed load	up to 75 kg	p. 118
Pitch diameter (DP)	chain S8=99.7 mm; chain S10=98 mm	

KFM-P 2040 Incline Conveyor Modular Belt



» Vertical transport
for connecting
different heights. «

The conveyor system KFM-P 2040, with its compact conveyor frame structure made from aluminium profile technology, is ideal for integration into existing machines or as a mobile transport unit for filling containers, for example.

The plastic modular belt, which is fully guided through PE1000 wear strips, is used to transport slugs or moulded plastic parts, light punched parts or food products. The material of the modular belt offers a high level of wear-resistance and abrasion resistance. The conveyor system offers various chain materials to make it suitable for food, suitable for high temperatures or resistant to chemicals.

Accessories such as side plates and transverse cleat profiles are also included in the product range. The slots in the profiles allow for easy connection of accessories such as funnels and discharge slides. Depending on the project you wish to convey, please also see our incline conveyor with a belt or hinged plate belt.

Benefits of the KFM-P 2040

- Moving transport unit for mobile use
- Ideal for integration into existing systems
- High load capacities available
- Positive drive mechanism eliminates slippage and makes it suitable for wet applications
- Stable chain travel regardless of the length/width ratio
- Chain material is highly resistant to wear and abrasion, making it suitable for high temperatures, contact with chemicals or food, etc.
- Accessories such as side boards and transverse cleat profiles available

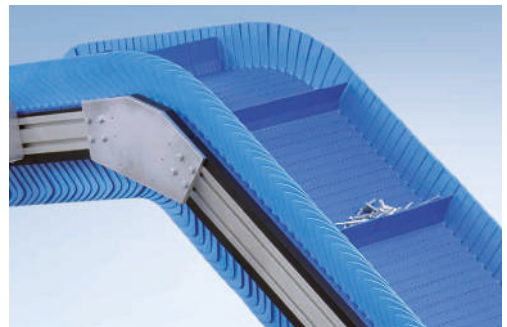
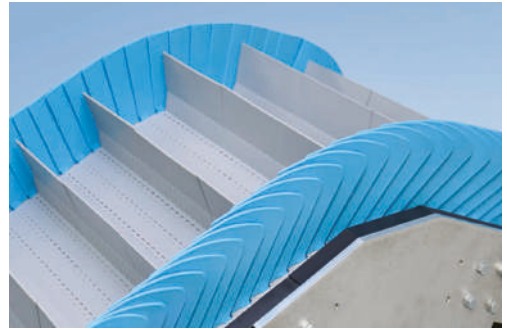

Cross Section

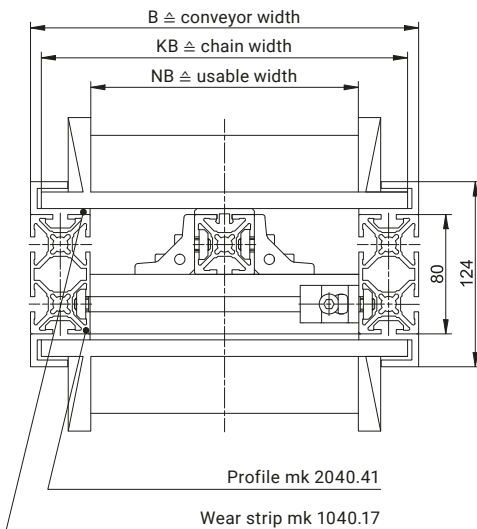

Properties

For the drive version AC, mk offers a multitude of drive motors tailored to various speed and load capacity requirements. The sprocket wheels ensure excellent transmission of the motor power. At lengths of up to three metres, the chain does not sag but the belt still runs quietly. With lengths of around three metres or more, there is chain sagging on the drive end, which is enclosed by a protective box. This results in an additional obstructing edge.

Type S: B20.40.810, type K: B20.40.811, type L: B20.40.812

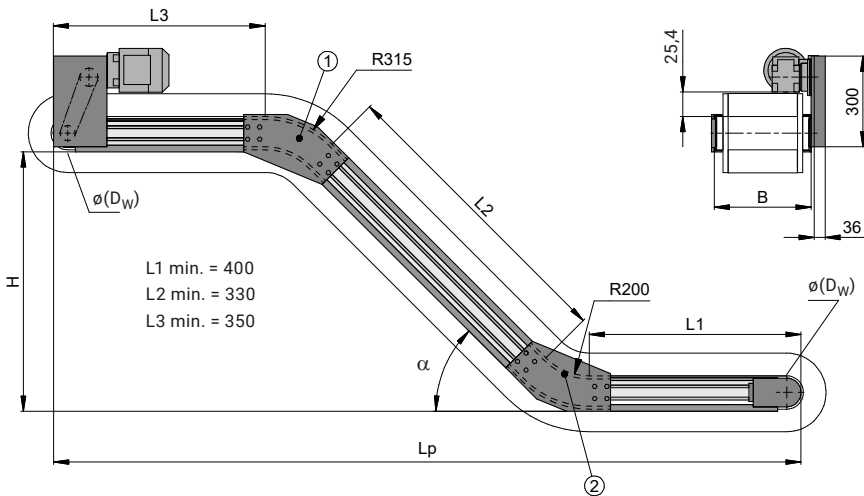

Technical data

Conveyor length L ($L_1+L_2+L_3$)	depending on the belt shape and load, usually up to 4000, max. 10000 mm (max. length based on the angle of alpha and L2)	
Conveyor width B	approx. 200–1000 mm depending on the chain type	p. 142
Drive location	discharge end left/right, underneath/above	
Drive and speed	up to 30 m/min	p. 12
Stands		p. 128
Total load	up to 100 kg (including chain weight)	p. 118
Distributed load	up to 50 kg/m, 15 kg/compartment	p. 118
Belt incline α 1 and 2	30, 45 and 60°	others on request
Pitch diameter (DP)	chain S8=99.7 mm; chain S10=98 mm	



Properties

The drive positioned laterally on the outside allows the total height of the conveyor to be restricted to a minimum. The sprocket wheel with the positive-locked connection to the modular belt ensures excellent transmission of the motor power. At lengths of up to three metres, the chain does not sag but the belt still runs quietly. With lengths of around three metres or more, there is chain sagging on the drive end, which is enclosed by a protective box. This results in an additional obstructing edge.

Type S: B20.40.813, type K: B20.40.814, type L: B20.40.815

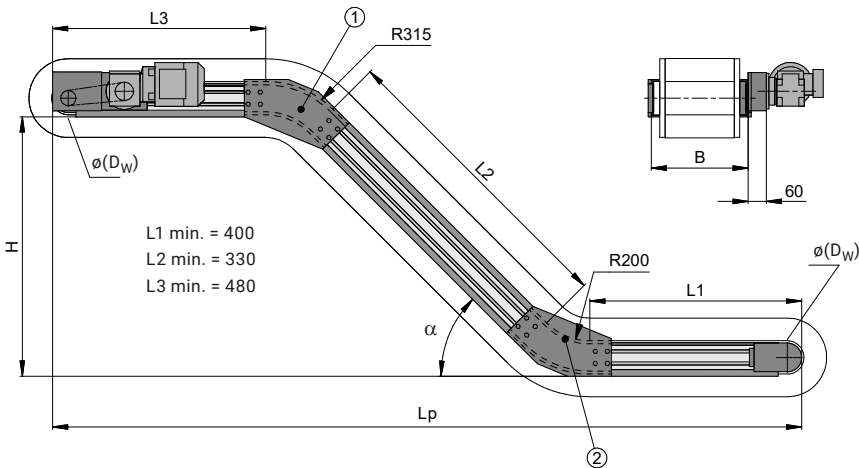

Technical data

Conveyor length L (L1+L2+L3)	depending on the belt shape and load, usually up to 4000, max. 10000 mm (max. length based on the angle of alpha and L2)	
Conveyor width B	approx. 200–1000 mm depending on the chain type	p. 142
Drive location	discharge end left/right	
Drive and speed	up to 30 m/min	p. 12
Stands		p. 128
Total load	up to 100 kg (including chain weight)	p. 118
Distributed load	up to 50 kg/m, 15 kg/compartment	p. 118
Belt incline a 1 and 2	30, 45 and 60°	others on request
Pitch diameter (DP)	chain S8=99.7 mm; chain S10=98 mm	



KFM-P 2040

Stand Type ECO

The stand was developed specially for the incline conveyor belt and incline conveyor modular belt and is characterised by its simplicity and light-weight design with the mk 2040.40 profile.

The swivel casters used have a total locking device, which guarantees a secure footing even at high transport speeds. The height and width of the stand is adapted based on the configuration; see the order example on the right.

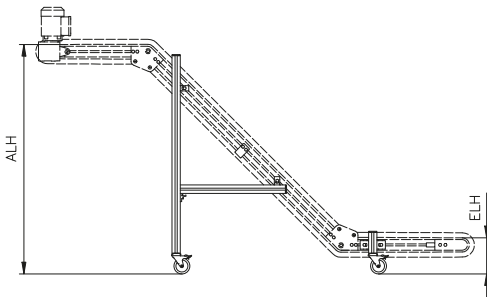

- ELH = infeed height
- ALH = discharge height
- B = conveyor width
- H = stand height
- L = length of the vertical profile
- AW = distance from the angle to the profile edge

Infeed End Stand B67.06.014

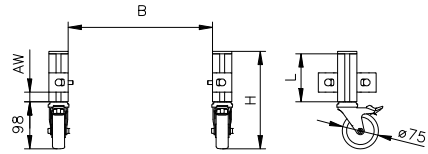

Infeed height (ELH) = 166–349 mm

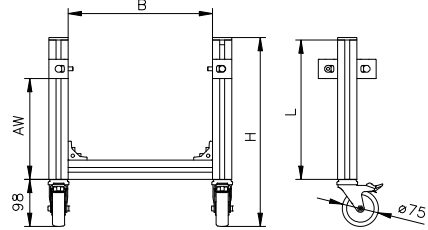

Infeed height (ELH) = 350–500 mm

Discharge End Stand B67.06.015

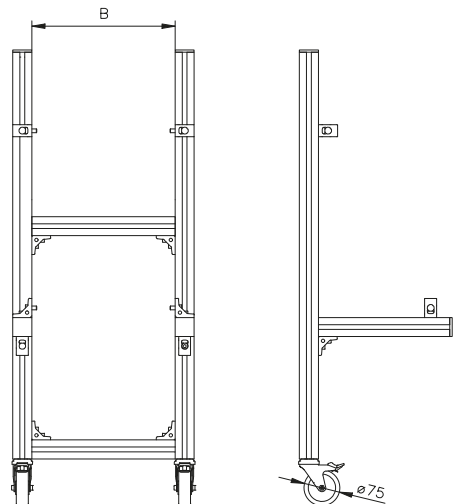

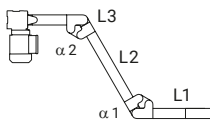
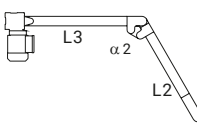
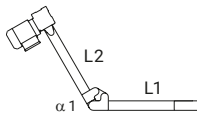
Sample order	Type designation		
KFM-P 2040 type S (B20.40.810)		Drive	AC AS
Drive AC, 0° motor orientation (as shown)	Type S 	B20.40. ...	810 813
Speed of 15 m/min			
Conveyor width B = 460 mm			
Conveyor length L1 = 500 mm; L2 = 1000 mm; L3 = 600 mm	Type K 	B20.40. ...	811 814
Belt incline a 1 = 60°; belt incline a 2 = 60°			
Cam height H1/S8 = 25.4 mm (see page 127)			
Stand, incline conveyor, type ECO	Type L 	B20.40. ...	812 815
Infeed height ELH = 200 mm			
Discharge height ALH = 1200 mm			

Curved Modular Belt Conveyor KMF-P 2040



» A variety of track layouts with just one drive. «

The curved modular belt conveyor KMF-P 2040 is the curved version of this conveyor type. The curve is available with different track layouts (L/S/U) and curve angles of 45° and 90°.

The conveyors range in width from 164 mm to 1005 mm and offer excellent usable width ratios, which is important if space is limited at your facility. They can be combined with straight sections (MBF-P 2040) and vertical inclines (KFM-P 2040) to adapt the track layout to your existing production conditions and create virtually any three-dimensional configuration.

Modular belt conveyors are extremely robust and can be used in a multitude of ways for almost every transport application. The belts are wear resistant and can even be used to transport goods with sharp edges or to transport goods in harsh application environments. The conveyor system also offers various chain materials to make it suitable for food, suitable for high temperatures or resistant to chemicals.

Benefits of the KMF-P 2040

- High load capacities available
- Positive drive mechanism eliminates slippage and makes it suitable for wet applications
- Maximum usable width with low total width
- Lateral movement of conveyed products
- Chain material is highly resistant to wear and abrasion, making it suitable for high temperatures, contact with chemicals or food, etc.
- Variable track layouts with just a single drive, different speeds at no additional cost

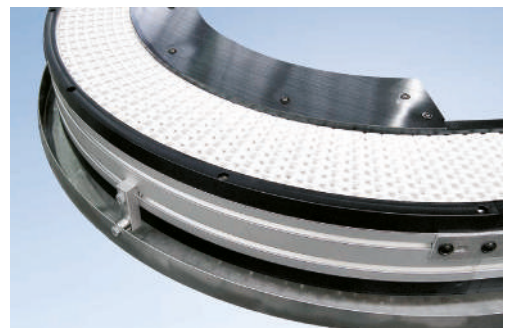
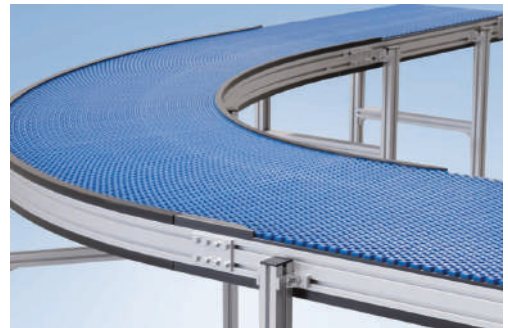
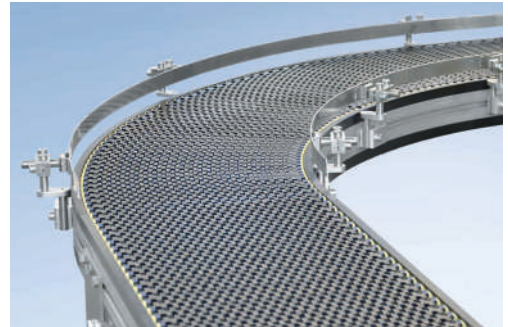
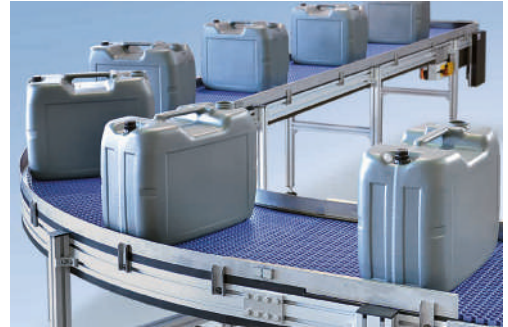

Cross Section

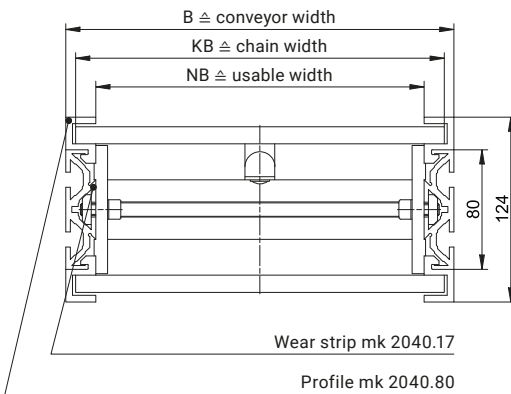

KMF-P 2040

Properties

The curved modular belt conveyor KMF-P 2040 has a modular design and, with just one drive for complex track layouts, is extremely efficient. At lengths of up to three metres, the chain does not sag but the belt still runs quietly. With lengths of around three metres or more, there is chain sagging on the drive end, which is enclosed by a protective box. This results in an additional obstructing edge.

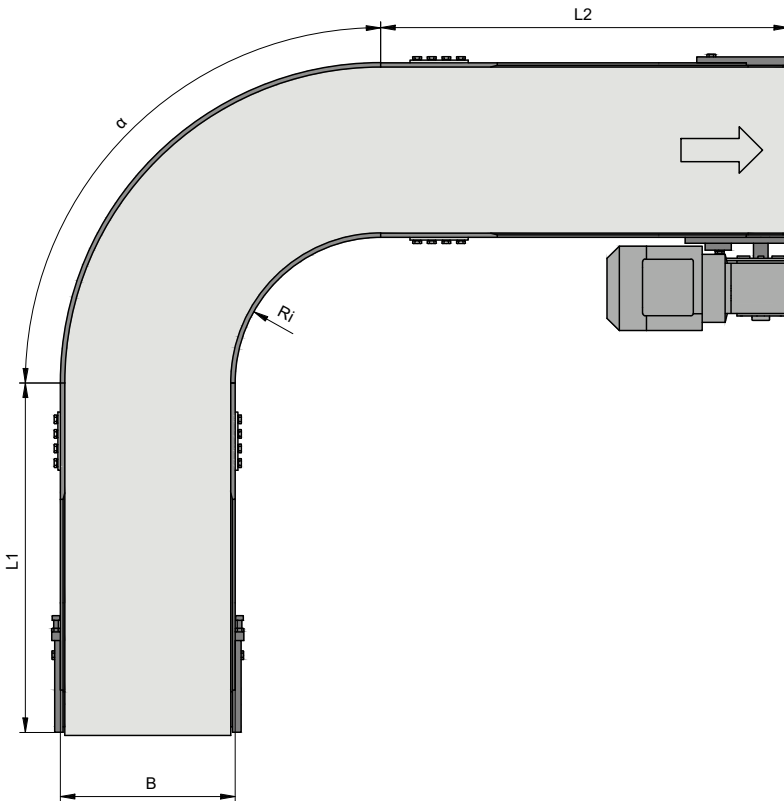

Technical data

Curve angle α	45° and 90° (in combination, also 135° and 180°)
Drive	head drives AC, AF and AS
Speed	5 to 30 m/min
Load capacity	depending on the track layout, conveyor length and conveyor width, up to 150 kg. Higher on request.
Cleats and side plates	the chain can be fitted with optional transverse cleats and side plates with H = 25 mm.

KMF-P 2040 Variants

3

Curve L45°

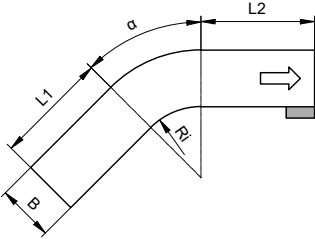

Curve L90°

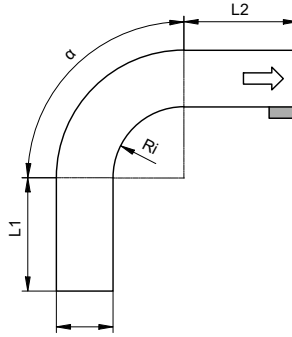

Curve L135°
(also available as L180°)

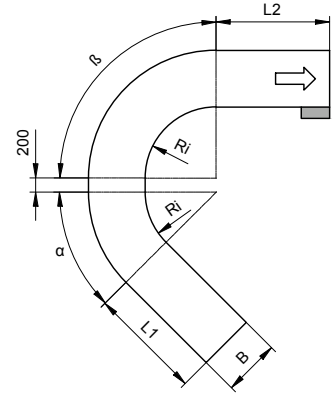

Examples of a Track Layout

Track S

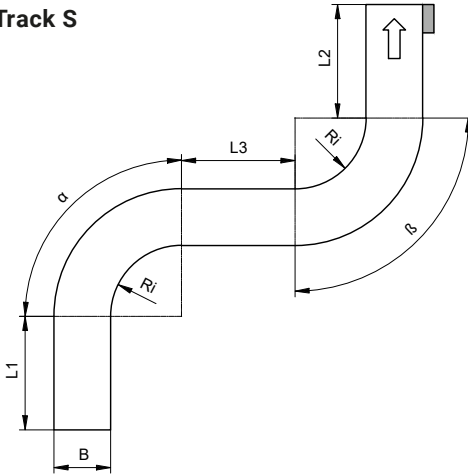

Track U

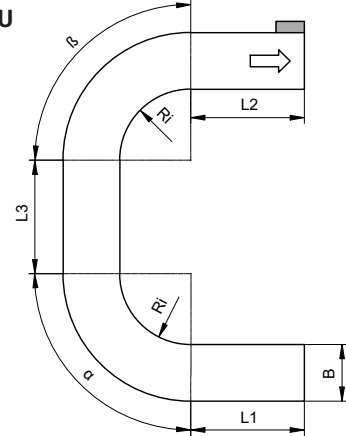

Dimensions [mm]

only for L45° or L90°

Conveyor width (B)	164	241	317	394	470	546	623	699	776	852	928	1005	
Chain width (KB)	149	226	302	379	455	531	608	684	761	837	913	990	
Usable width (NB)	134	211	287	364	435	511	588	664	741	817	893	970	
Length L1 (min.)	224	339	453	569	683	797	912	1026	1142	1256	1370	1485	
Length L2 (min.)	645	645	645	758	910	1062	1216	1368	1522	1674	1826	1980	
Length L3 (min.)	Track S	400	452	604	758	910	1062	1216	1368	1522	1674	1826	1980
	Track U	400	400	400	400	400	400	400	400	400	400	400	
Inner radius (Ri)	324	493	660	830	997	1164	1334	1501	1670	1837	2005	2174	

3

Head drive AC

Type L: B20.40.826 | Type S: B20.40.827 | Type U: B20.40.828

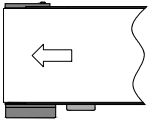
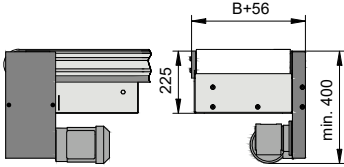

Properties	Standard head drive. Drive version with a variety of combination options for motors, gearboxes and sprocket wheels.
Drive location	discharge end left/right
Motor orientation	0°, 90°, 180°
Speed	5 to 30 m/min

Head drive AF

Type L: B20.40.823 | Type S: B20.40.824 | Type U: B20.40.825

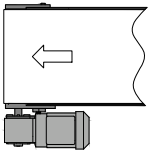
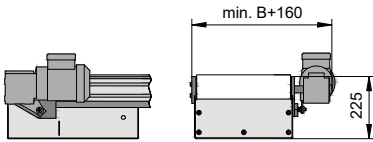

Properties	Direct head drive. Compact and low-maintenance drive version with a motor that is fitted directly on the drive shaft
Drive location	discharge end left/right
Motor orientation	0°, 90° (front terminal box), 180°, 270°
Speed	5; 7; 10; 12.5; 17; 20.5; 26; 29.5 m/min

Head drive AS

Type L: B20.40.820 | Type S: B20.40.821 | Type U: B20.40.822

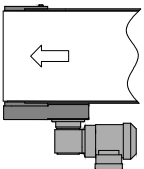
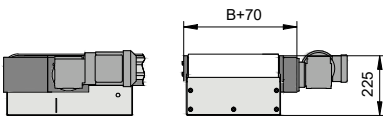

Properties	Compact head drive, positioned laterally on the outside. A drive version restricted to a minimum total height with motor mounted on the outside
Drive location	discharge end left/right
Motor orientation	0°, 90°, 180°, 270°
Speed	5 to 30 m/min

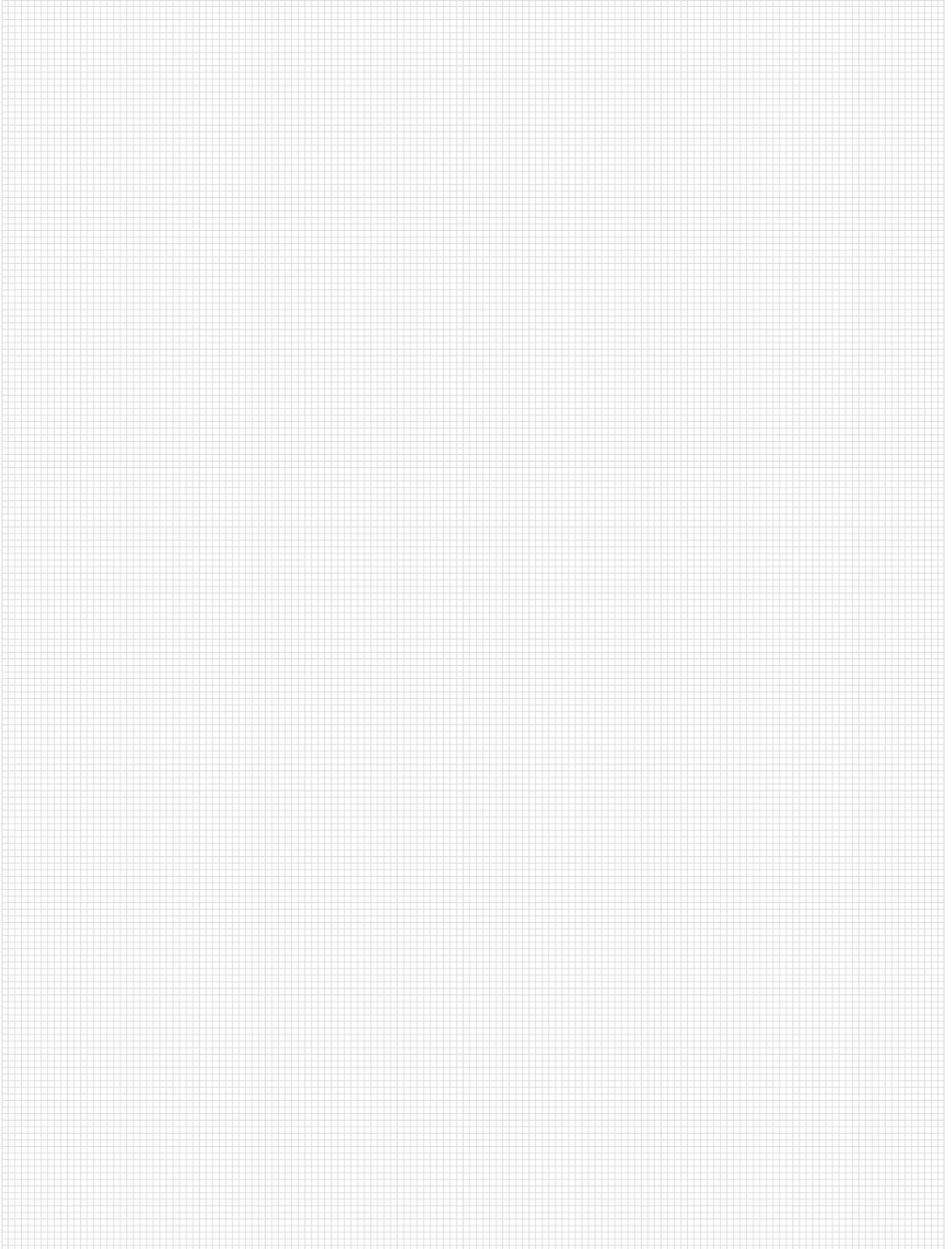

Incline Conveyor Hinged Plate Belt KFS-P 2040.86



» Hinged plate belt with steel chain for durable transport. «

With its compact conveyor frame made from aluminium profile technology, the KFS-P 2040.86 conveyor system is ideally suited for demanding continuous duty in multi-shift operation. The hinged plate belt is fully guided through wear strips and used for transporting stamped, cast, forged and wooden parts. With a gap of 1 to 3 mm between the chain and the side rail, this conveyor system is not suitable for pointed stamping scraps or metal chips.

The particularly robust steel chain is also available in a stainless steel or perforated design on request. It is suitable for transporting hot products. The conveyor system's modular design combined with the general advantages of profile technology make the conveyor excellently suited for integration into existing systems or for use as a mobile transport unit, e.g. for filling containers.

The slots in the profiles allow for easy connection of accessories such as side rails, stands, funnels and discharge slides. The use of standard components enables mk to achieve rapid delivery times and an excellent price-performance ratio. Custom solutions, such as special funnels, are available on request. Depending on the project you wish to convey, please also see our incline conveyor with a belt or modular belt.

Benefits of the KFS-P 2040.86

- Vertical transport for connecting different heights
- Stable and heat-resistant surface
- For transporting stamped, cast, forged or wooden parts and for hot product
- High load capacities available
- Transverse cleats for transporting small pieces or bulk product

Cross Section

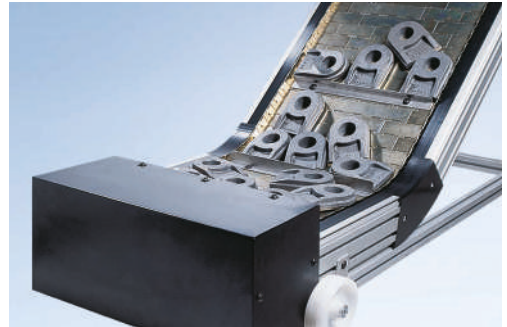
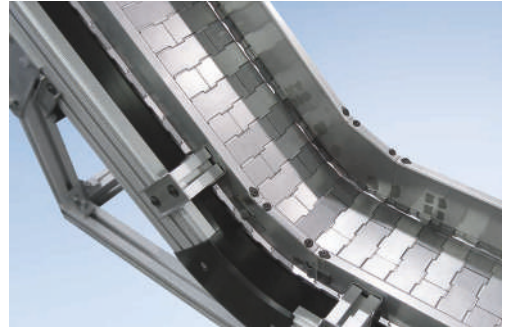
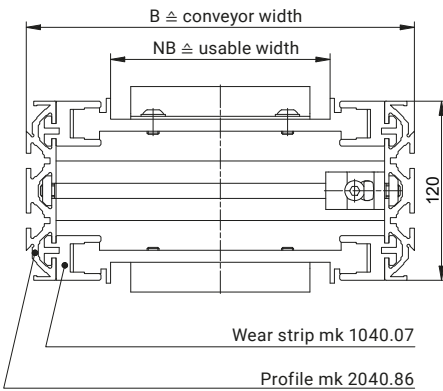

Properties

For the drive version AC, mk offers a multitude of drive motors tailored to various speed and load capacity requirements. The sprocket wheels ensure excellent transmission of the motor power.

3

Type S: B20.40.606, type K: B20.40.607, type L: B20.40.608, type G: B20.40.605

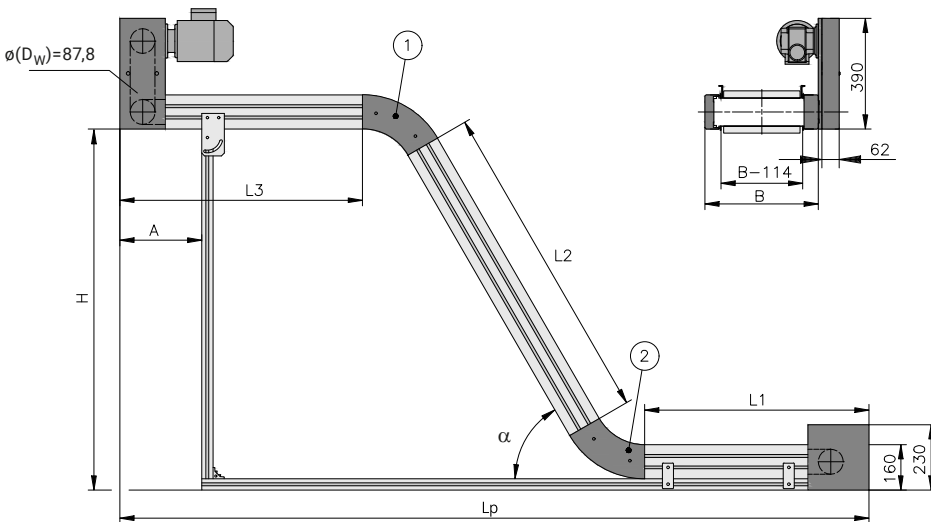

Technical data

Conveyor length L (L1+L2+L3)	depending on belt shape and load, up to 10000 mm	
Conveyor width B	210 to 710 mm (in 50 mm increments)	others on request
Drive location	discharge end left/right, underneath/above	
Drive and speed	up to 12 m/min	p. 12
Stand and side rail		from p. 140
Total load	up to 150 kg	p. 118
Distributed load	up to 50 kg/m, 15 kg/compartment	p. 118
Belt incline α 1 and 2	15, 30, 45 and 60°	others on request



Properties

The drive positioned laterally on the outside allows the total height of the conveyor to be restricted to a minimum. The sprocket wheel with the positive-locked connection to the modular belt ensures excellent transmission of the motor power.

3

Type S: B20.40.610, type K: B20.40.611, type L: B20.40.612, type G: B20.40.609

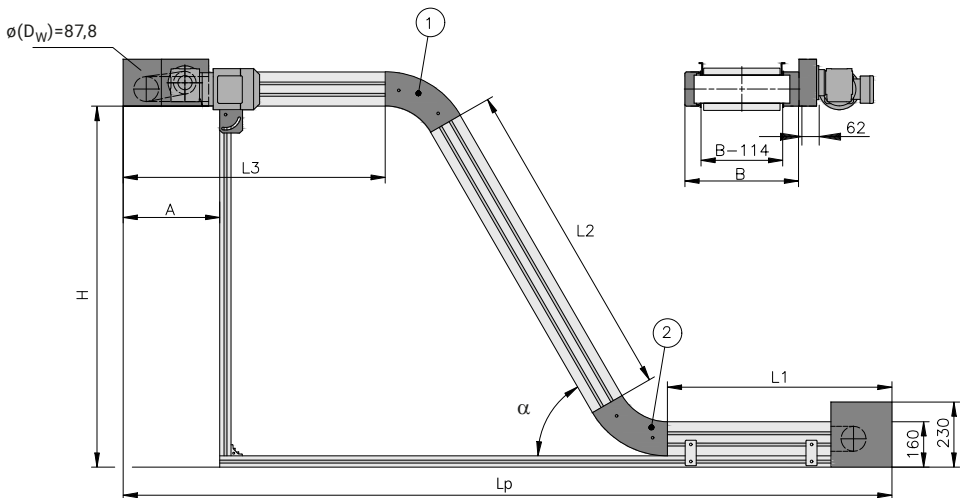

Technical data

Conveyor length L (L1+L2+L3)	depending on belt shape and load, up to 10000 mm	
Conveyor width B	210 to 710 mm (in 50 mm increments)	others on request
Drive location	discharge end left/right	
Drive and speed	up to 12 m/min	p. 12
Stand and side rail		from p. 140
Total load	up to 150 kg	p. 118
Distributed load	up to 50 kg/m, 15 kg/compartment	p. 118
Belt incline α 1 and 2	15, 30, 45 and 60°	others on request



KFS-P 2040.86

Stands

The stand type shown, stand type A, can be equipped with all the pad options. All the stands in the mk conveyor technology range can be used with type G.

The swivel casters used in pad option 1 have a total locking device and guarantee stability even at high transport speeds.

They are available as \varnothing 75 mm for $x=113$ mm, \varnothing 100 mm for $x=140$ mm and \varnothing 125 mm for $x=165$ mm.

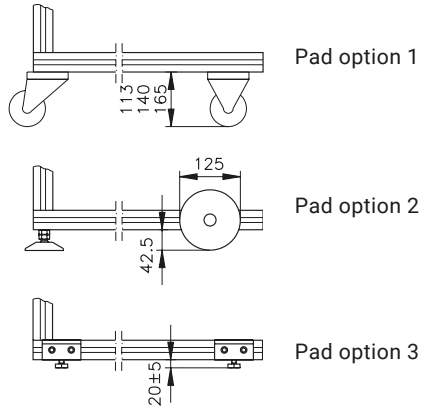
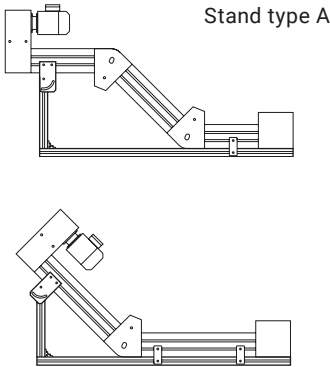

Sample order

KFS-P 2040.86 type S (B20.40.606)

- Drive AC 0° motor orientation (as shown)
- Speed of 10 m/min
- Conveyor width B = 460 mm
- Conveyor length
L1 = 500 mm; L2 = 1000 mm; L3 = 600 mm
- Belt incline α 1 = 60°; belt incline α 2 = 60°
- Cam height H1 = 20 mm (see page 133)
- Stand type A, pad option 1, \varnothing 75 mm roll
- Infeed height ELH = 200 mm
- Discharge height ALH = 1200 mm

Type designation

		Drive	AC	AS
Type S		B20.40. ...	606	610
Type K		B20.40. ...	607	611
Type L		B20.40. ...	608	612
Type G		B20.40. ...	605	609

Side Rail SF 8.1

B17.00.026

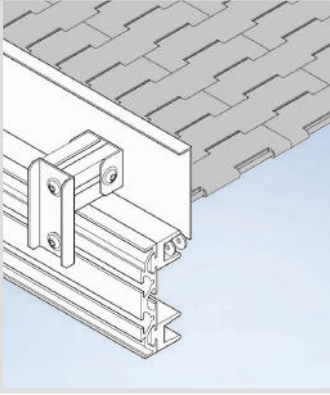

The side rails shown are our standard version and are available with rapid delivery times.

They seal the gap (up to 1–3 mm) between the chain and conveyor frame.

Height H=75 mm
 Height H=100 mm

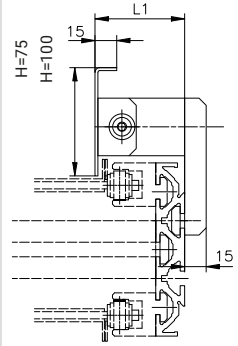

Modular Belts

... for MBF-P 2040

mk offers two chain series for its modular belt conveyor system to meet various customer requirements. Series 8 modular belt chains are suitable for transporting medium-weight to heavy goods such as containers, bottles, boxes, and so on, in industrial applications. Series 10 is suitable for transport of light to medium-heavy goods in hygiene-sensitive areas. The side plates are available in heights of 25, 50, 75 and 100 mm and in the colours light blue and white.

Series 8 (S8)

Series 10 (S10)

Conveyor width B [mm]	Chain width KB [mm]	Conveyor width B [mm]	Chain width KB [mm]
218.00	203.20	206.00	190.50
269.00	254.00	263.00	247.65
320.00*	304.80*	320.00*	304.80*
371.00	355.60	358.00	342.90
409.00	393.70	416.00	400.50
460.00	444.50	472.00	457.20
510.00*	495.30*	510.00*	495.30*
561.00	546.10	568.00	552.45
612.00	596.90	606.00	590.55
663.00*	647.70*	663.00*	647.70*
714.00	698.50	720.00	704.85
764.00	749.30	758.00	742.95
815.00*	800.10*	815.00*	800.10*
866.00	850.90	872.00	857.25
917.00	901.70	910.00	895.35
968.00*	952.50*	968.00*	952.50*
1018.00	1003.30	1006.00	990.60

*Belt width/chain width is identical for Series 8 and 10. They can be swapped with each other without changing the conveyor frame.

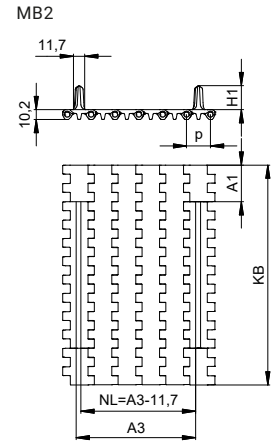
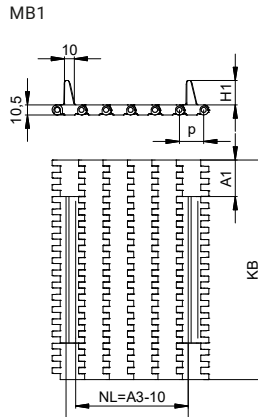
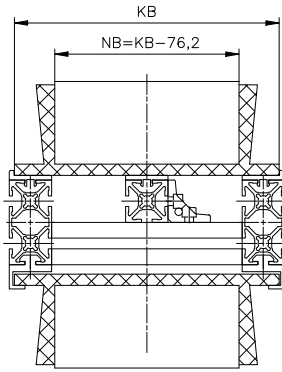

Modular Belt

Series 8 (S8)

Series 10 (S10)

Cam height H1

25.4 mm and 76.2 mm
 others on request

25 mm and 100 mm
 others on request

Cam spacing A3

25.4 mm in grid

25.4 mm in grid

Spacing p

25.4 mm

25.4 mm

Modular belt thickness

10.5 mm

10.2 mm

Min. edge clearance A1

With KFM, 38.1 mm

With KFM, 38.1 mm

FDA/USDA suitability

Partly

FDA approval

Material

PP:
 +5 to +100° C
 Colours: white, light grey

PE:
 -70 to +65° C
 Colours: white, light blue

POM:
 -40 to +90° C
 Colours: blue

PP:
 +5 to +100° C
 Colours: white, light blue

POM CR:
 -45 to +90° C
 Colours: anthracite

POM:
 -45 to +90° C
 Colours: white, light blue

- Specially resistant to impacts and cuts
- Easy to clean
- Minimal scoring
- Low risk of material separation

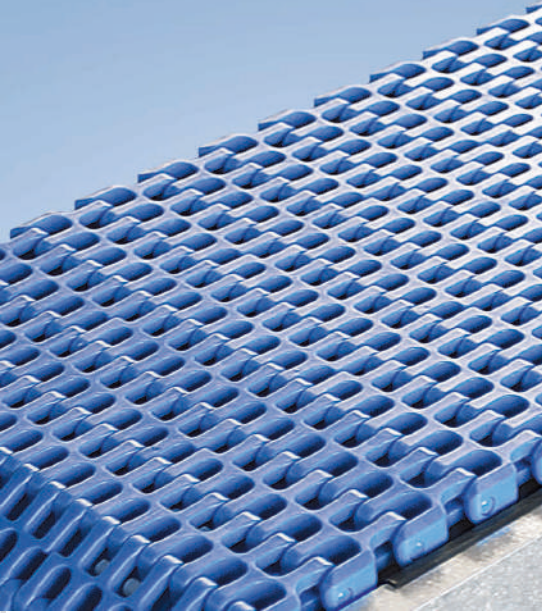

The modular belt ASB 2.2 is highly resistant to wear and abrasion, making it suitable for high temperatures, contact with chemicals or food, etc.

Modular Belts

... for KMF-P 2040

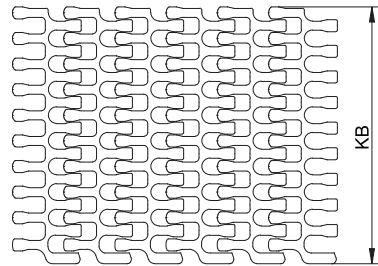
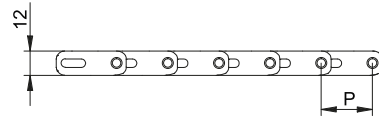

Modular Belt

ASB 2.2

Chain width KB	149, 162, 226, 302, 379, 455, 531, 608, 684, 761, 837 and 914 mm
Spacing p	25.4 mm
Modular belt thickness	12 mm
Minimum radius (internal)	2.2 x chain width (KB)
Back-flex radius	25.0 mm
FDA/USDA suitability	FDA approval
Material	POM: -40 to +90° C Colours: blue



... for KFS-P 2040.86

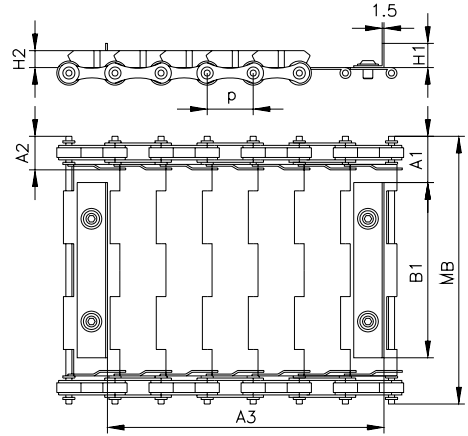

The particularly robust hinged plate belt is also available in a stainless steel or perforated design on request.

Hinged Plate Belt

SK1

A1 (without side plate/with side plate)	38.1 mm
A2	25 mm
MB	147–647 mm
Cam height H1	20/40 mm
Side plate height H2	14 mm
Cam spacing A3	38.1 mm in grid
Colour	Bright steel
Spacing p	38.1 mm
Chain thickness	13 mm
Material	Steel
FDA/USDA suitability	No
Technical properties	Steel Wear-resistant Heat-resistant up to 300° C Resistant to impact Low friction coefficient

Max. total width B3 Tolerance ± 3.0 mm	147	197	247	297	347	397	447	497	547	597	647
Weight, kg/linear metre	4.6	5.6	6.6	7.7	8.7	9.7	10.8	11.8	12.8	13.9	14.9

Application Examples

3

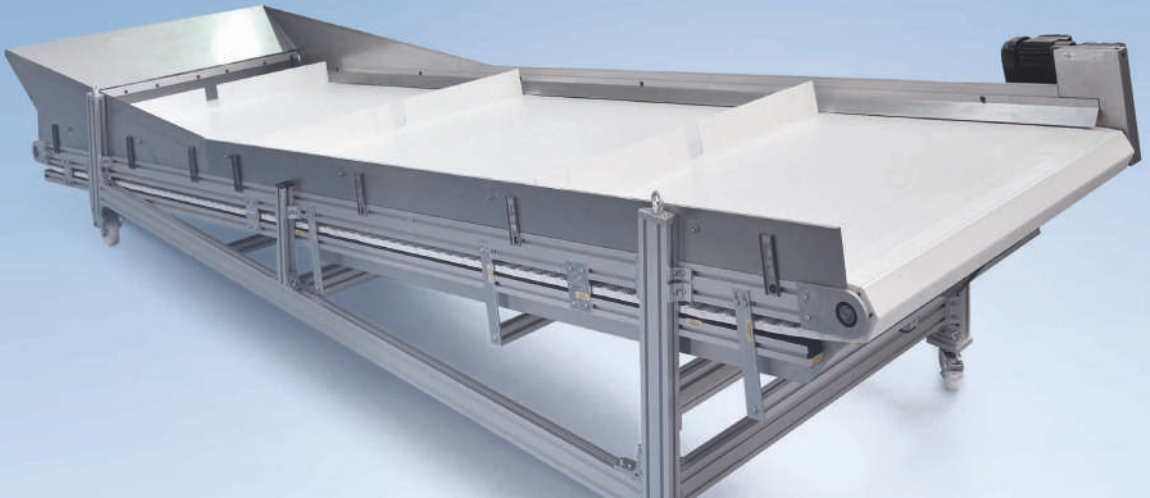

MBF-P 2040 with head drive AC as inclined conveyor with collection hopper and movable support frame



MBF-P 2040 interlinking with a side rail on one side and a side wall on the opposite side to support the product



MBF-P 2040 with side wall and cleats



Cycled modular belt conveyor with bolted-on tubular brackets in a special design



3

MBF-P 2040 with head drive AC and drip pan

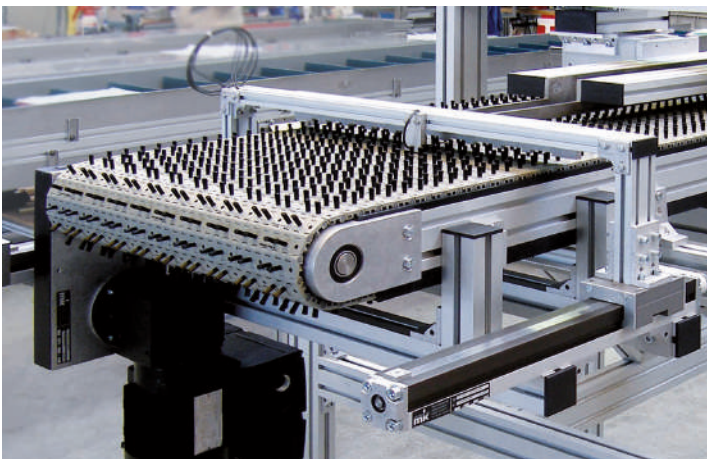

Modular belt conveyor MBF-P 2040 with head drive AC and plastic bristles for gentle transport

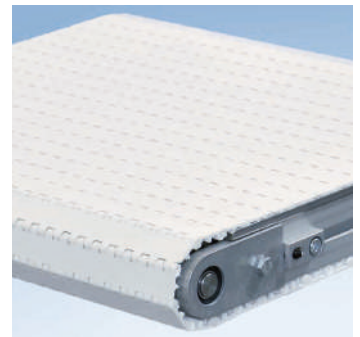

Special short MBF-P 2040 with laterally projecting modular belt chain

Application Examples



Curved KMF-P 2040 with 90° curve and adjustable side rails



Curved modular belt conveyors KMF-P 2040 with a drive for complex route layouts

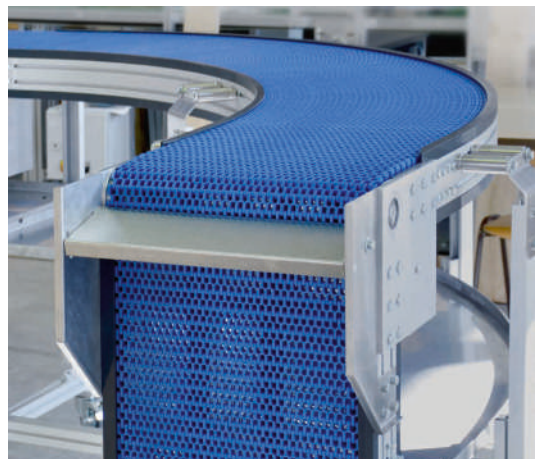

KMF-P 2040 with drip pan and discharge chute for oily stamped parts

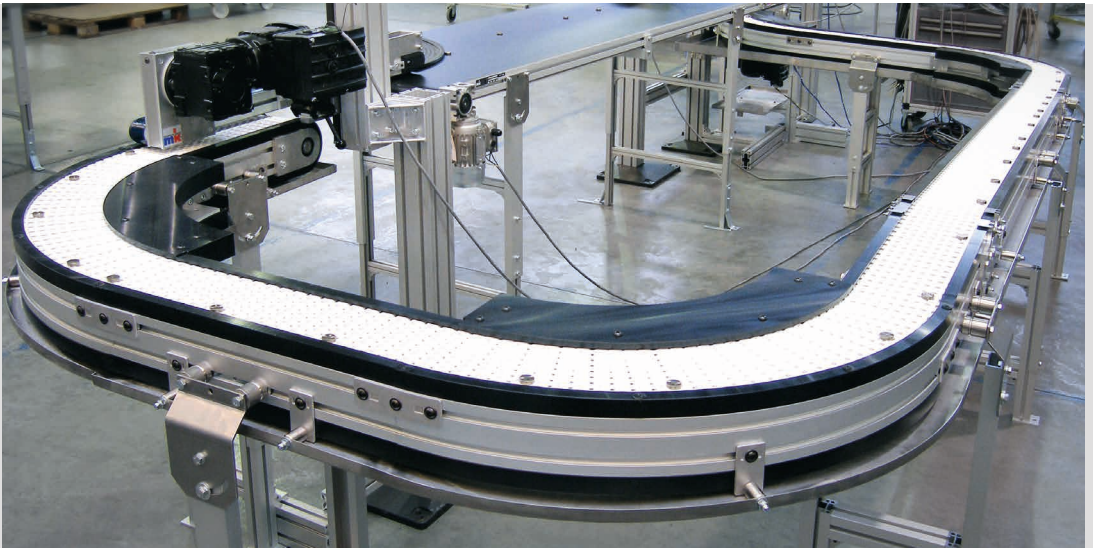

Curved KMF-P 2040 with head drive
AC and drip pan along the entire length



KMF-P 2040 as an infeed for empty canisters

Application Examples



KFM-P 2040 with drip pan and separator flap



Swivelling KFM-P 2040 with fixed fulcrum, swivel casters and locking mechanism



KFM-P 2040 head drive AS with protective box, hopper and drip pan in the lower run for slightly oily parts



KFM-P 2040 head drive AS with transverse cleats and side plate for the modular belt



Solid support of the KFS-P 2040.86
for conveying heavy loads



KFS-P 2040.86 for hot product with
resizeable supply reservoir



KF S-P 2040.86 head drive AC with
perforated hinged plate belt, transverse
cleats and burls for better product grip



KFS-P 2040.86 AF with two 45° inclines

Chapter 4 Timing Belt Conveyors

4



Selecting a Timing Belt Conveyor 154

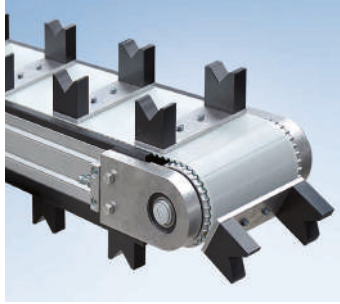

Timing Belt Conveyor ZRF-P 2040 156
Head Drives 158



Timing Belt Conveyor ZRF-P 2010 160
Head Drives 162
Lower Belt Drives 166
Wear Strips 168

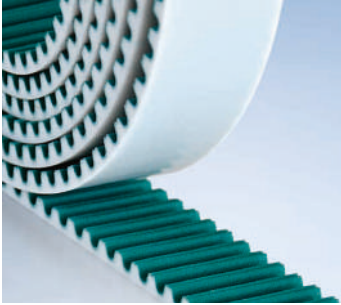

Timing Belts

170

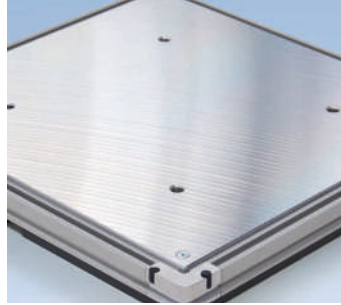

Accessories

- Pallets 172
- SU – Stopper Undamped 174
- SD – Stopper Damped 175



Application Examples

176

Selecting a Timing Belt Conveyor

Dimensions – Technical Data

Conveyor system	Conveyor widths [mm]	Conveyor lengths [mm]	Total load* As standard, up to [kg]	Speed up to [m/min]	ø of tails [mm]	Reverse operation	Accumulated operation	Cycling operation
Timing belt conveyor (single-line)								
ZRF-P 2040	40/80/120/160	650–6000	250	60	approx. 102		•	•
Timing belt conveyor (double-line)								
ZRF-P 2010	200–1000	500–6000	250	60	approx. 89		•	•

*Maximum load that is transported by the system in question with a standard configuration and for a standard application. The permissible load depends on the width, timing belt material, load distribution, operating mode and environmental influences.

4

Selecting Double-line Conveyors based on Load and Speed

The diagram shows double-line conveyor systems based on their load and speed. The comparison shows timing belt conveyors (ZRF), chain conveyors (KTF) and accumulating roller chain conveyors (SRF).

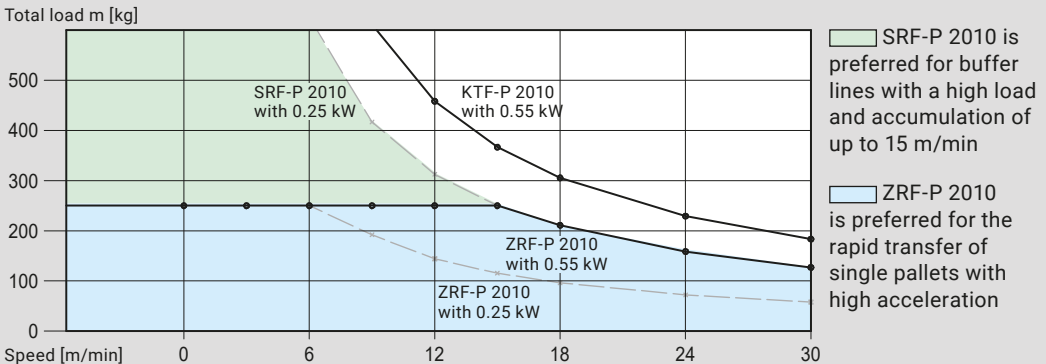

Total load m [kg] per conveying path, per drive in continuous operation (accumulated operation $m_{\text{accumulated}} = 2 \times m_{\text{continuous}}$)

Selecting the Stopper

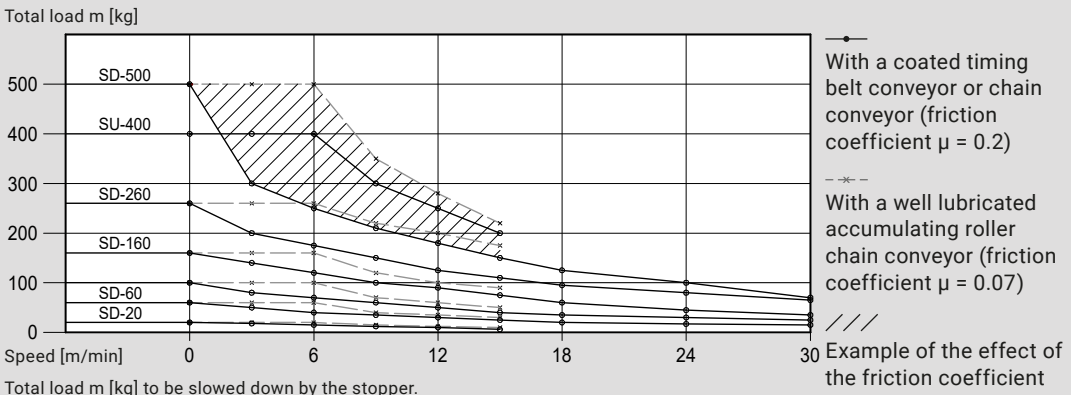

Total load m [kg] to be slowed down by the stopper.

Application Options

Timing belt conveyors are ideal for the cycled transport of products. Available with different drive variants and as a single, double or multiple line conveyor, they are often used to construct complex interlinking solutions. The double-line solution is frequently used for transporting pallets. In such applications, timing belt conveyors are used when high speeds and accelerations are required. Chain conveyors and accumulating roller chain conveyors are used for high loads (see the image on the left and the next chapter).

Our range of different timing belt materials allows you to find the optimal grip for the workpieces in your specific application. Options include aluminium timing belt pulleys, anodised timing belt pulleys and stainless steel timing belt pulleys (for reducing wear while improving corrosion resistance).

The **timing belt conveyor ZRF-P 2040** is predominantly used as a single-line solution. Ribs or threaded sleeves can be welded onto or preferably bolted onto the timing belt for product take-up. For bolted-on ribs, the AT timing belt is used due to the wider tooth shape. In addition to greater tooth rigidity and the larger load contact surface, this provides the necessary space for plug-in threaded sleeves. As a result, the system is also suitable for precisely feeding and positioning loads weighing up to 250 kg.

As a double-line system, **ZRF-P 2010 timing belt conveyors** are ideal for the cycled transport of pallets or products with a rigid structure. Combined with the wide range of drive options, the system is the perfect basis for constructing complex interlinking and automation systems. The timing belt return inside the profile allows for a compact design and reduces the risk of accidents to a minimum.

Timing Belts

The standard timing belts are made from polyurethane reinforced with high-strength steel cords. The belts in the 2010 system have the T10 partition and are up to 32 mm wide (others available on request). To ensure optimal transport, different surface coatings can be used (see page 159).

A coating on the teeth side (PAZ = polyamide tooth-side) is recommended for conveyor speeds above 30 m/min. Since standard timing belts with the PU base material on the teeth side tend to produce noise when passing over the aluminium timing belt pulley a PAZ coating, in addition to good lubrication, is a reliable solution to this problem.

The PAZ coating takes the form of a nylon fabric on the teeth side and is also available in an impregnated version to meet ESD requirements. This use of this nylon fabric in cleanroom applications is controversial because of the fine abrasion particles it produces. Many of our customers prefer the larger, visible particles produced by the PU base material. We can also provide a conductive base material on request for use with electronic parts and in explosive atmospheres.

Timing Belt Conveyor ZRF-P 2040

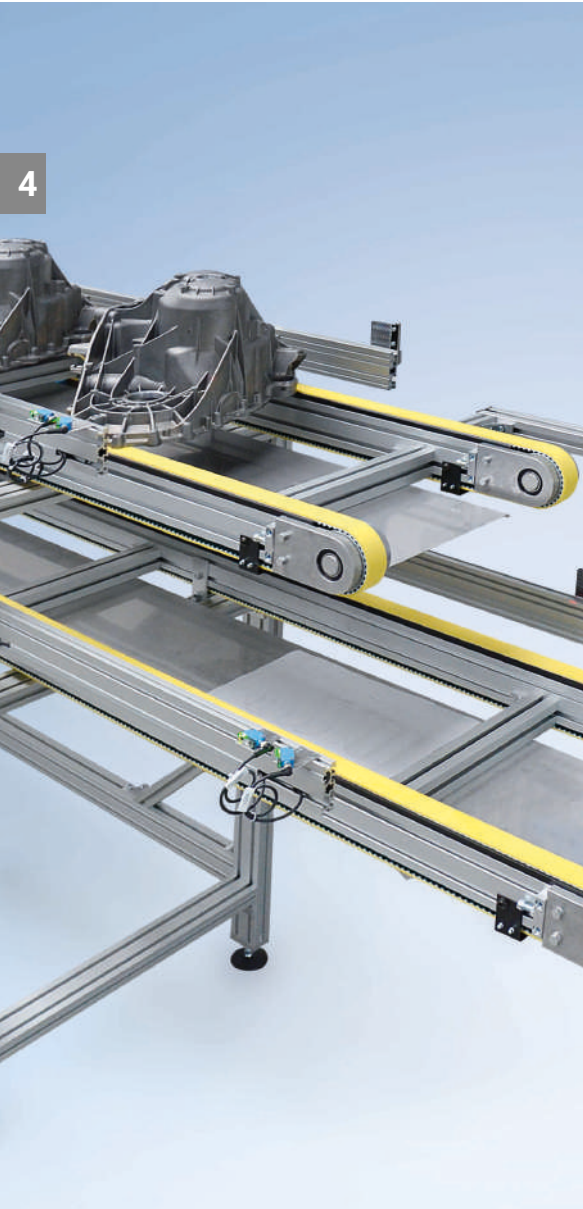

» For cycled transport and precise positioning. «

The ZRF-P 2040 timing belt conveyor system is ideally suited for use as a single line conveyor for the cycled transport of piece goods. The goods can be transported conventionally or with a specific orientation.

In addition to different coatings that provide optimal gripping of the workpiece, various ribs to hold the workpiece can also be attached to the surface of the timing belt, either welded on or preferably screwed on.

The system is suitable for exact conveying, feeding and positioning up to a total load of 250 kg. The system offers different timing belt widths to suit your particular application, workpiece dimensions and total load.

The conveyor frame profile also offers system slots (10 mm slot width) on both sides for connection stands, side rails, initiators and stoppers.

Benefits of the ZRF-P 2040

- Cycled transport of piece goods, either conventional or orientated
- Precise conveying, feeding and positioning up to 250 kg
- Available as a single, double or multiple line conveyor
- Various belt coatings for optimal gripping of the workpiece
- Ribs can be attached to hold the workpieces

Cross Section

conveyor width of 80 mm for this example

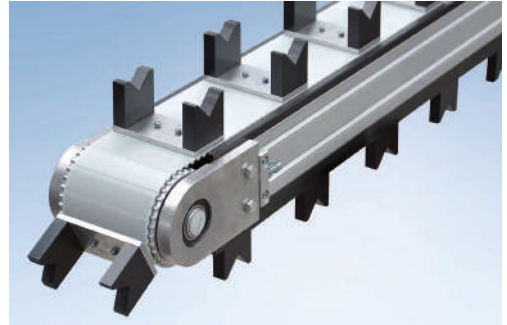
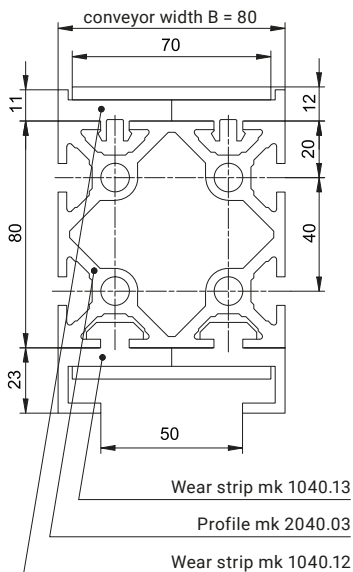

4

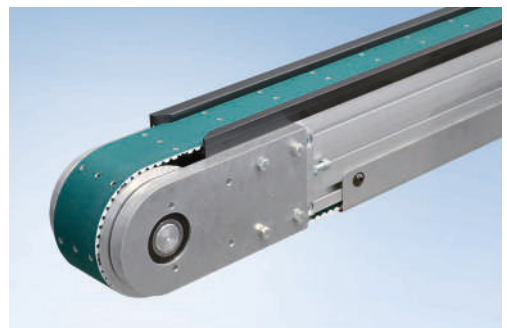
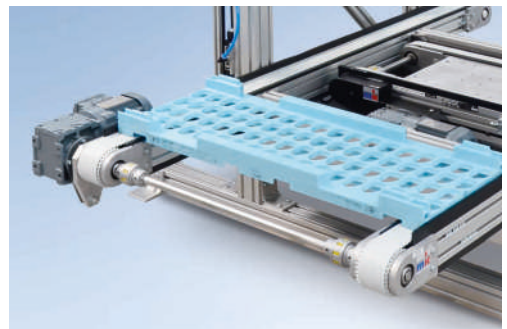
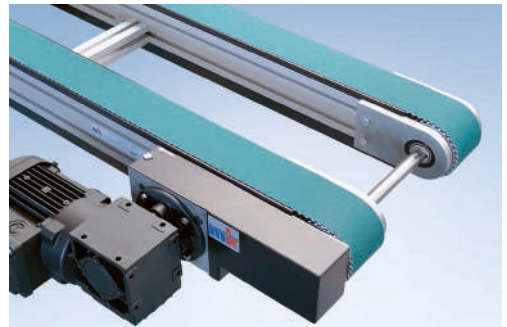

Properties

The timing belt pulley ensures excellent transmission of the motor power. When using ribs, the max. possible height must be requested.

4

B20.40.301

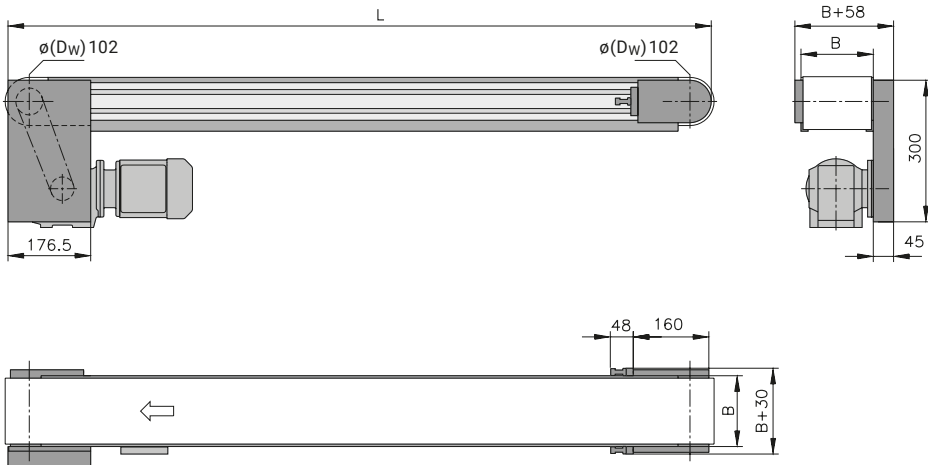

Technical data

Conveyor length L	individual from 650 to 6000 mm	
Conveyor width B	40/80/120/160 mm	others on request
Timing belt width	32/70/110/150 mm	
Timing belt type		p. 170
Drive location	discharge end left/right, underneath	
Drive and speed	up to 60 m/min, higher on request	p. 12
Stand and side rail		from p. 280
Standard total load	up to 125 kg for B = 40 mm/up to 250 kg for B = 80 mm or wider	higher on request
Standard distributed load	up to 50 kg/m for B = 40 mm/up to 100 kg/m for B = 80 mm or wider	



Properties

The drive positioned laterally on the outside allows the total height of the conveyor to be restricted to a minimum. The timing belt pulley ensures excellent transmission of the motor power. Use of ribs is possible without restriction with this drive version.

B20.40.302

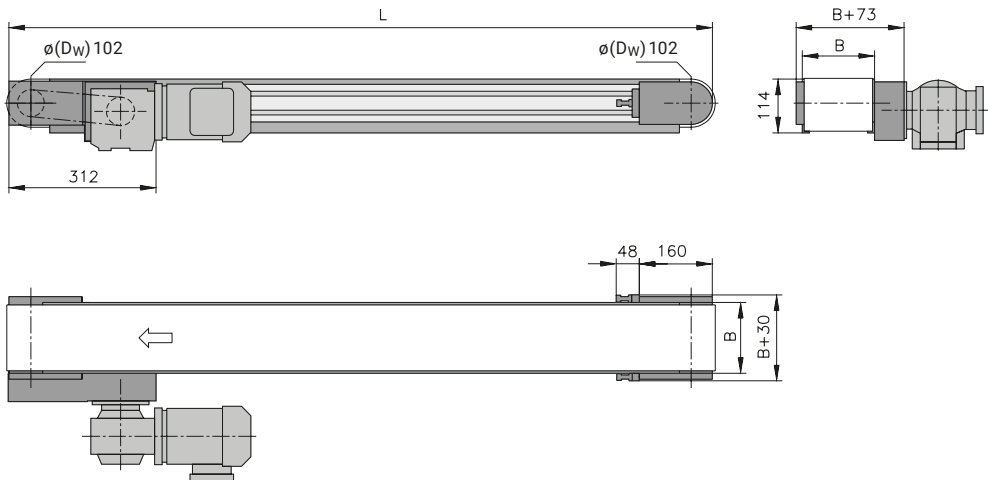

Technical data

Conveyor length L	individual from 650 to 6000 mm	
Conveyor width B	40/80/120/160 mm	others on request
Timing belt width	32/70/110/150 mm	
Timing belt type		p. 170
Drive location	discharge end left/right	
Drive and speed	up to 60 m/min, higher on request	p. 12
Stand and side rail		from p. 280
Standard total load	up to 125 kg for B = 40 mm/up to 250 kg for B = 80 mm or wider	higher on request
Standard distributed load	up to 50 kg/m for B = 40 mm/up to 100 kg/m for B = 80 mm or wider	

Timing Belt Conveyor ZRF-P 2010



» For transporting pallets and products with a rigid structure. «

The ZRF-P 2010 timing belt conveyor system is ideally suited for transporting heavy pallets and products with a rigid structure. The positive connection between the drive pulley and the timing belt ensures that the two conveyor lines are synchronised, making the system ideally suited for cycling operation.

A feature of this conveyor system are the wear strips made from ultra-high-molecular weight polyethylene on which the timing belt runs and is guided. This material provides a low coefficient of friction and excellent wear characteristics over a wide temperature range (up to 65° C over extended periods). Another typical feature of this system is the recirculation of the timing belt inside the profile frame. This reduces the risk of accidents to a minimum.

The profile offers system slots (10 mm slot width) on three sides for connecting stands, side rails and stoppers. Combined with the wide range of different drive options, this makes the system the perfect basis for constructing complex inter-linking and automation systems. Various coatings on the surface of the timing belt ensure optimal gripping of the workpiece for your specific application.

Benefits of the ZRF-P 2010

- Double line and multiple line conveyor for transporting pallets and products with a rigid structure
- Ideally suited for cycling operation, up to 250 kg
- Timing belt recirculates inside the profiles to produce a compact design
- Various belt coatings for optimal gripping of the workpiece
- Wide range of different drive options

Cross Section

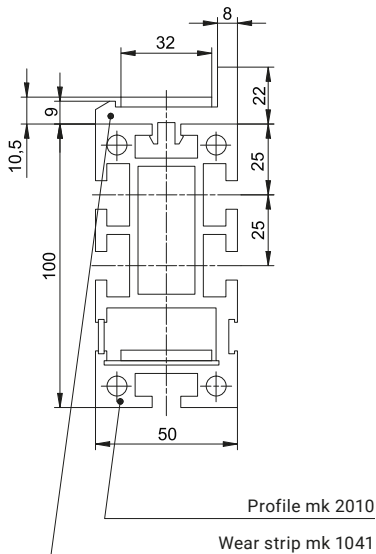

4

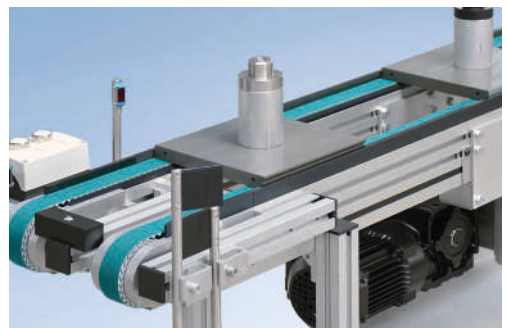
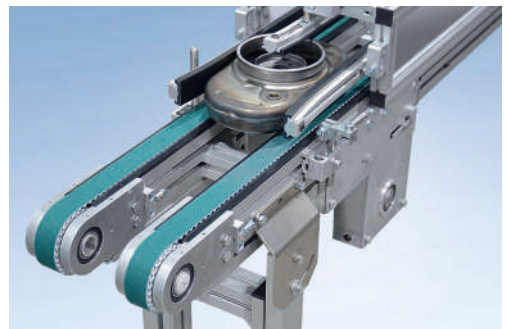

Properties

The drive variant AA without a motor offers the advantage of operating multiple conveyor lines in parallel or in series with one drive. Depending on the requirement, the conveyor is designed either with a hollow shaft or with a connecting shaft with shaft journal ($\varnothing 20$ mm, usable length 34 mm, incl. DIN 6885 key) Operation with welded-on ribs is not possible with this version.

4

B20.10.350

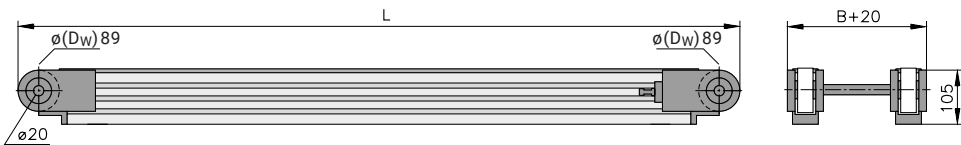

For information about wear strip variants, see page 168

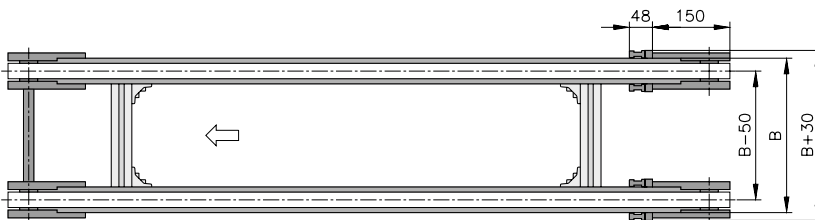

Technical data

Conveyor length L	individual from 500 to 6000 mm	
Conveyor width B	200 to 1000 mm	
Timing belt width	32 mm	p. 170
Drive and speed	up to 60 m/min, higher on request	p. 12
Stand and side rail		from p. 280
Standard total load	up to 250 kg	higher on request
Standard distributed load	up to 100 kg/m	



Properties

The timing belt pulley ensures excellent transmission of the motor power. Operation with welded-on ribs is not possible with this version.

B20.10.351

4

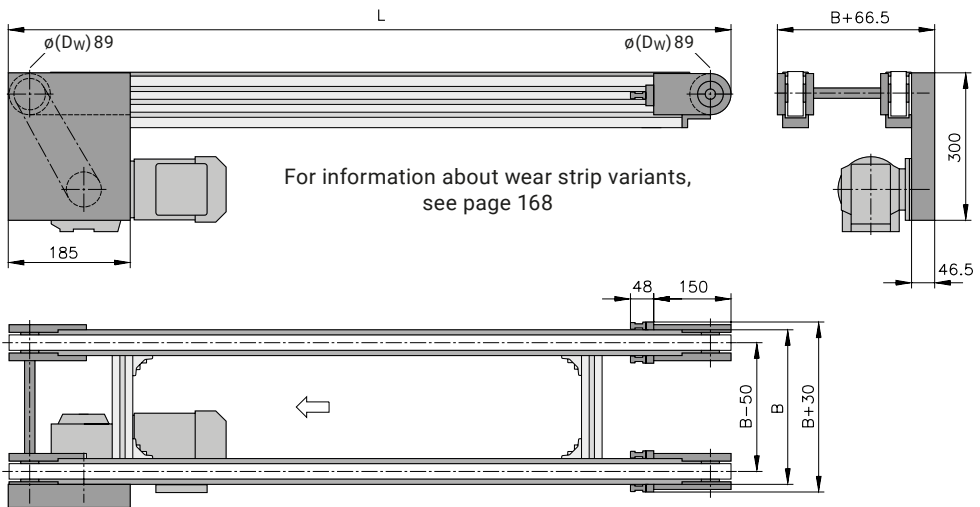

Technical data

Conveyor length L	individual from 500 to 6000 mm	
Conveyor width B	200 to 1000 mm	
Timing belt width	32 mm	p. 170
Drive location	discharge end left/right, underneath	
Drive and speed	up to 60 m/min, higher on request	p. 12
Stand and side rail		from p. 280
Standard total load	up to 250 kg	higher on request
Standard distributed load	up to 100 kg/m	

Properties

Since the motor is fitted directly onto the drive shaft, the space requirements and maintenance effort for this drive version are reduced to a minimum. Operation with welded-on ribs is not possible with this version.

4

B20.10.357

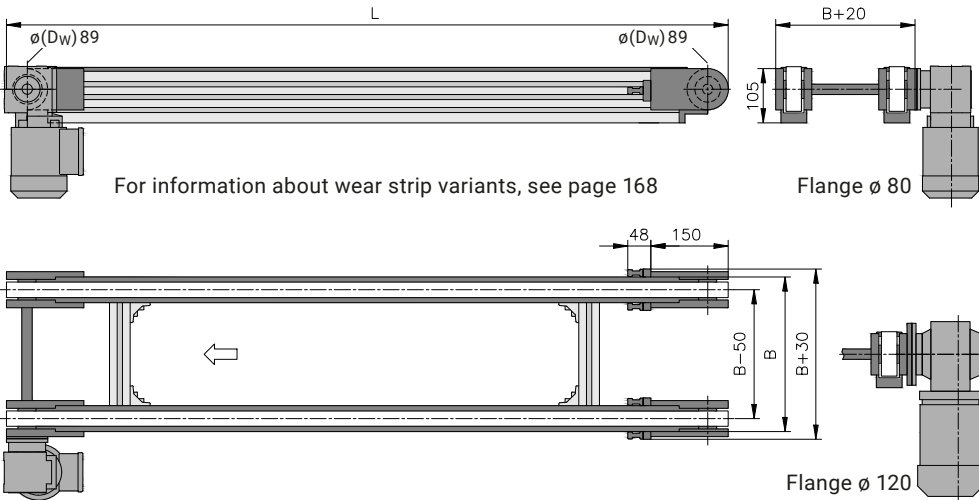

Technical data

Conveyor length L	individual from 500 to 6000 mm	
Conveyor width B	200 to 1000 mm	
Timing belt width	32 mm	p. 170
Drive location	discharge end left/right	
Drive and speed	up to 60 m/min, higher on request	p. 12
Stand and side rail		from p. 280
Standard total load	up to 250 kg	higher on request
Standard distributed load	up to 100 kg/m	



Properties

The drive positioned laterally on the outside allows the total height of the conveyor to be restricted to a minimum. Operation with welded-on ribs is not possible with this version.

B20.10.355

4

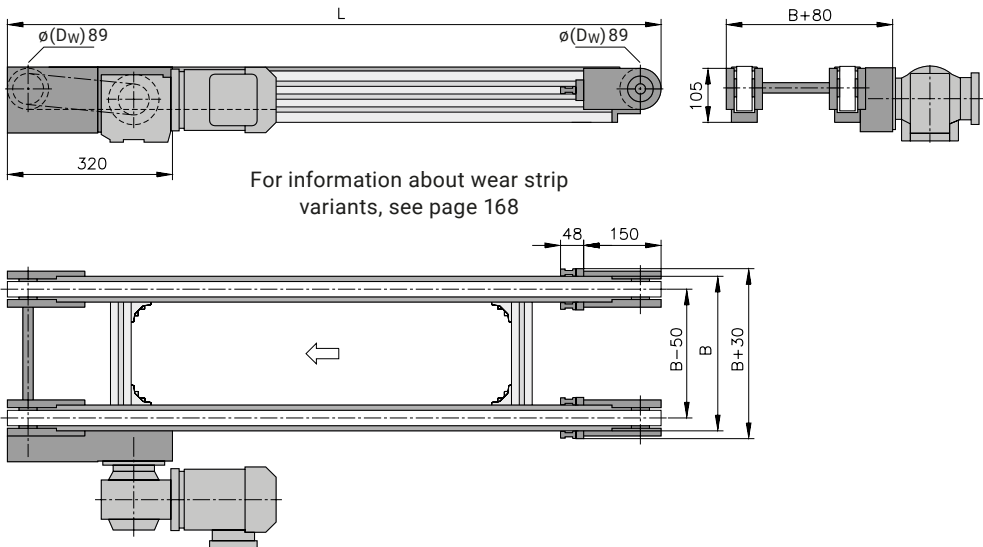

Technical data

Conveyor length L	individual from 700 to 6000 mm	
Conveyor width B	200 to 1000 mm	
Timing belt width	32 mm	p. 170
Drive location	discharge end left/right	
Drive and speed	up to 60 m/min, higher on request	p. 12
Stand and side rail		from p. 280
Standard total load	up to 250 kg	higher on request
Standard distributed load	up to 100 kg/m	

Properties

The compact conveyor frame design and the ability to freely select the drive position over the entire length of the conveyor make it easier to integrate the conveyor into existing systems. The timing belt pulley combined with the snub rollers ensures excellent transmission of the motor power. Operation with welded-on ribs is not possible with this version.

4

B20.10.356

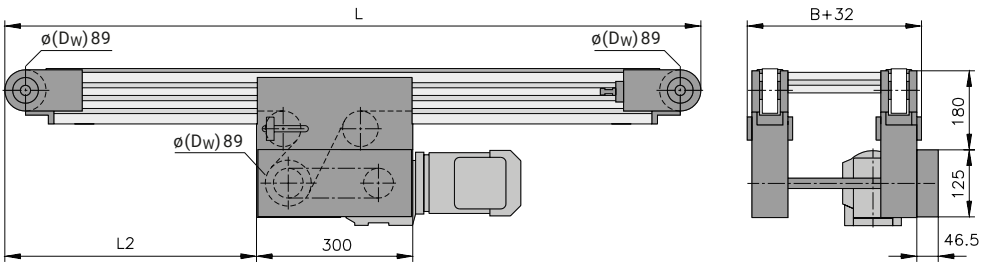

For information about wear strip variants, see page 168

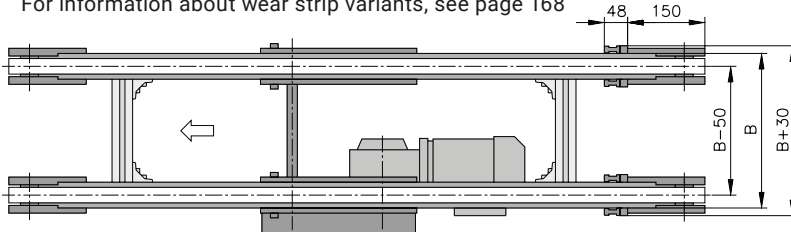

Technical data

Conveyor length L	individual from 700 to 6000 mm	
Conveyor width B	200 to 1000 mm	
Timing belt width	32 mm	p. 170
Drive location	left/right underneath	
Drive and speed	up to 60 m/min, higher on request	p. 12
Stand and side rail		from p. 280
Standard total load	up to 250 kg	higher on request
Standard distributed load	up to 100 kg/m	



Properties

Since the motor is fitted directly onto the drive shaft, the space requirements and maintenance effort for this drive version are reduced to a minimum. The compact conveyor frame design and the ability to freely select the drive position anywhere along the entire length of the conveyor make it easier to integrate the conveyor into existing systems. The conveying direction is reversible. Operation with welded-on ribs is not possible with this version.

B20.10.359

4

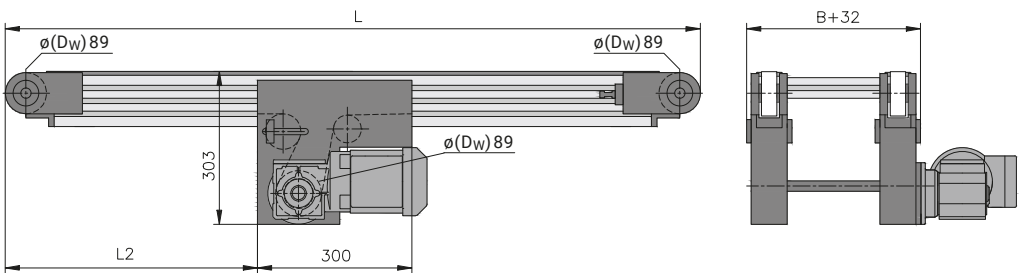

For information about wear strip variants, see page 168

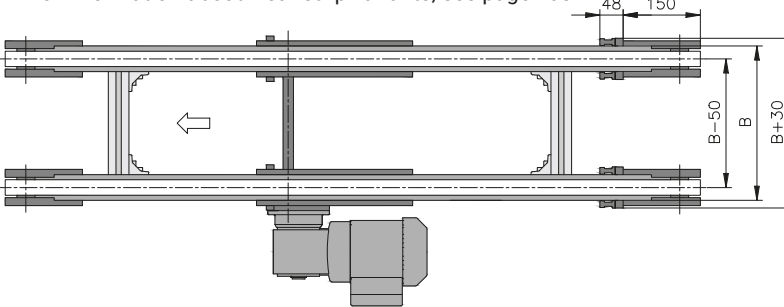

Technical data

Conveyor length L	individual from 700 to 6000 mm	
Conveyor width B	200 to 1000 mm	
Timing belt width	32 mm	p. 170
Drive location	left/right underneath	
Drive and speed	5; 6.3; 8; 9.5; 11.5; 13.5; 15.2; 19.3; 23; 26; 36.6; 45.7 and 57 m/min	p. 12
Stand and side rail		from p. 280
Standard total load	up to 250 kg	higher on request
Standard distributed load	up to 100 kg/m	

ZRF-P 2010 Wear Strips

4

Wear and guide strips from mk ensure low friction.

The wear strips are made from PE – UHMW (PE – 1000). Max. temperature 65° C.

Variant A

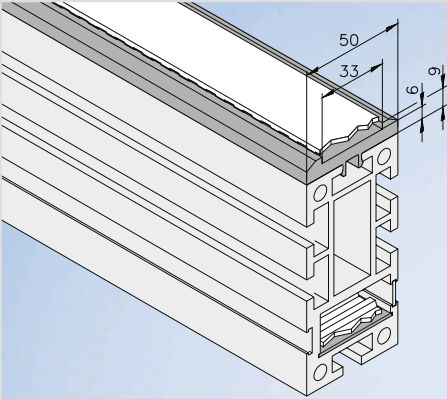

Top wear strip mk 1042

22.42.2000

Bottom wear strip

21.14.0001

Closure strip

K10230/12

Variant B

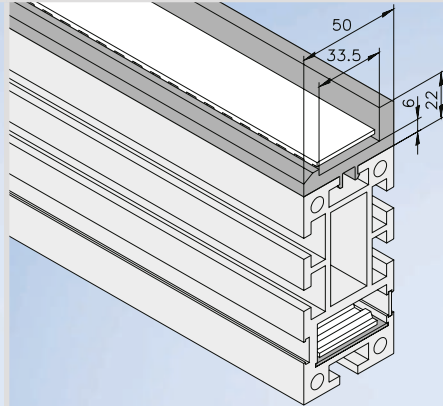

Top wear strip mk 1041

22.41.2000

Bottom wear strip

21.14.0001

Closure strip

K10230/12

Variant C

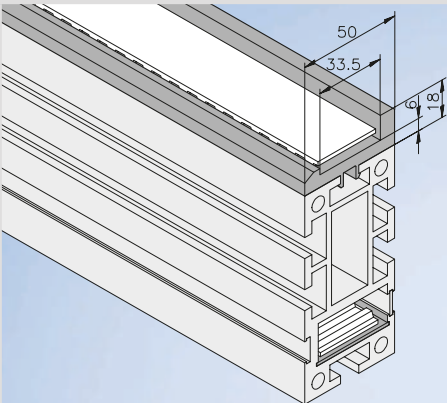

Top wear strip mk 1110

B20.10.359.600

Bottom wear strip

21.14.0001

Closure strip

K10230/12

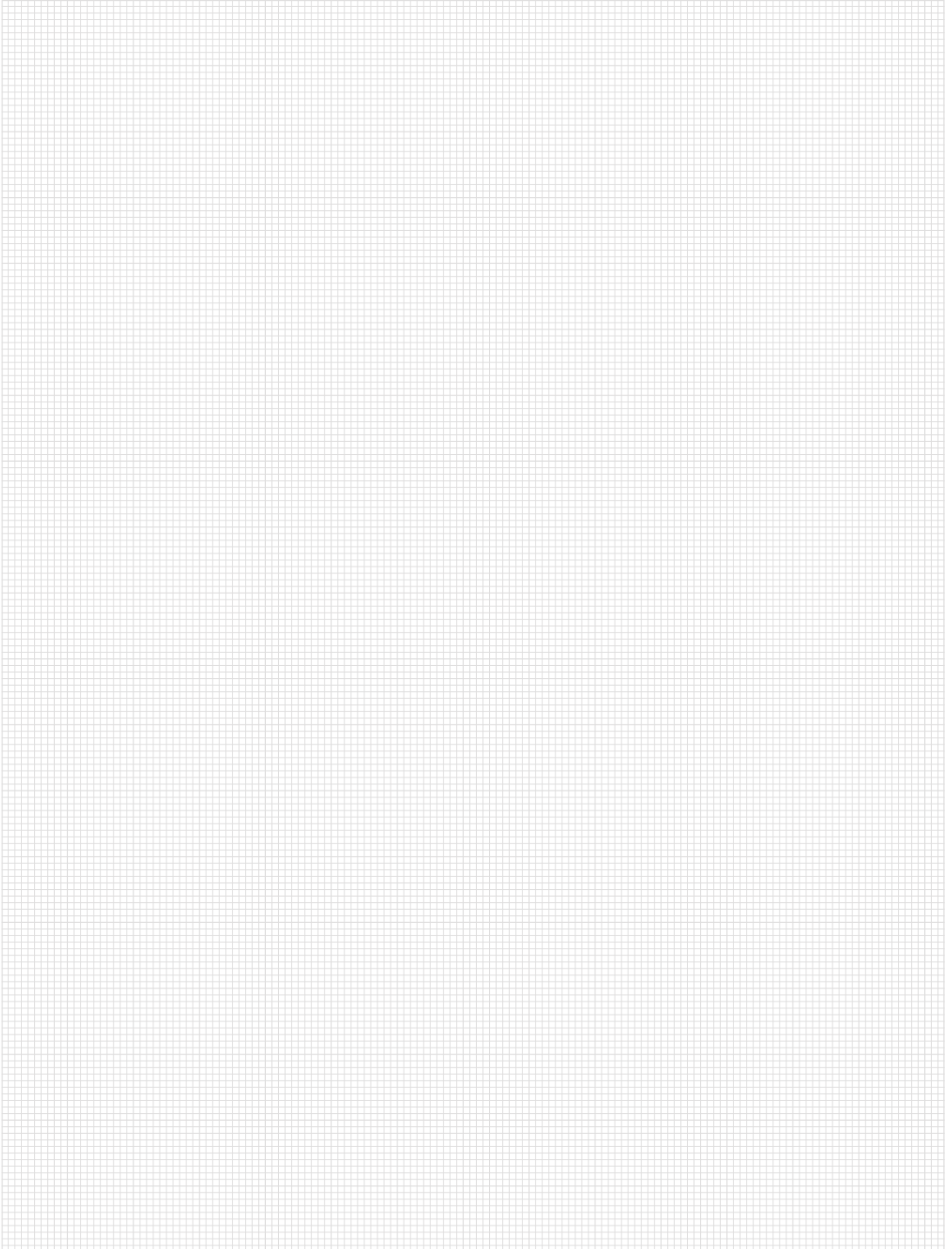

Timing Belts

The standard timing belts are made from polyurethane reinforced with high-strength steel cords. The belts have the T10 partition and a width of 32 mm (others available on request). To ensure optimal transport, different surface coatings can be used. An additional coating on the teeth side (PAZ = polyamide tooth side) is recommended for conveying speeds above 30 m/min as well as to reduce friction and noise.

Timing belt material

Properties	Basic material		Surface coating		
	Polyurethane	Polyamide PAR/PAZ**	PVC, white, FDA	Rubber structure (Supergrip)*	Linatex***
Resistance to moisture	+				+
Resistance to oil and grease	+		+ -	+	+ -
Suitable for contact with food (FDA compliant)			+		
Abrasion resistance	+				+ -
Wear resistance				+	
Adhesion property (inclined conveying)				+	++
Anti-frictional property (accumulated operation)	-	+			-
Cut resistance	+				
Low noise levels		+ (PAZ)			
Colour	Various	Green	White	Green	Red
Temperature resistance	-20 to +60° C	-20 to +60° C	-40 to +100° C	-10 to +90° C	-40 to +70° C
Hardness	90 Shore A		65 Shore A	40 Shore A	40 Shore A

*Not suitable for use in ZRF-P 2010 except as a special version with conveyor frame open on the bottom

**PAR = polyamide rear (carrying) side; PAZ = polyamide tooth side

***Counter-bending, such as in lower belt drives, is not permitted

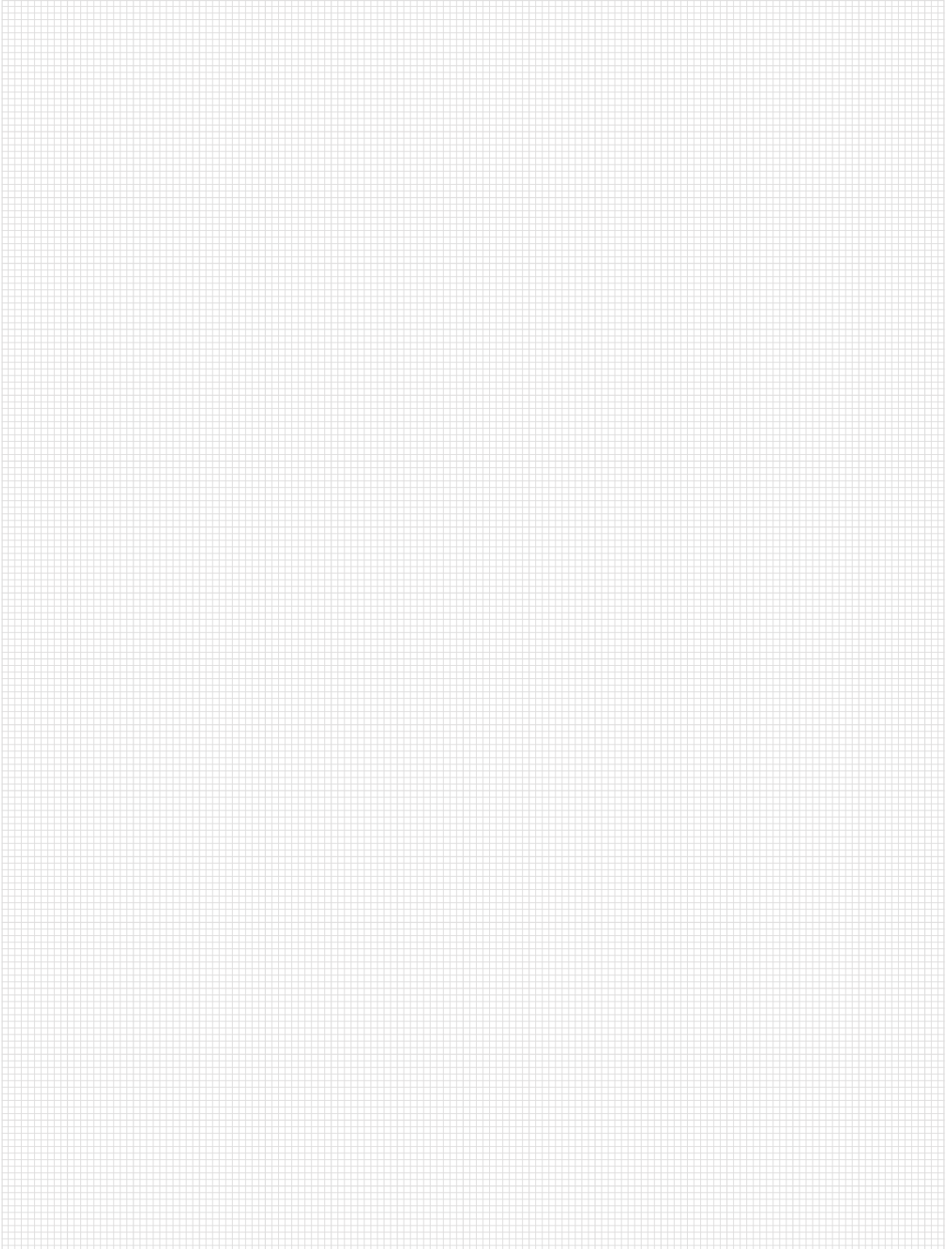

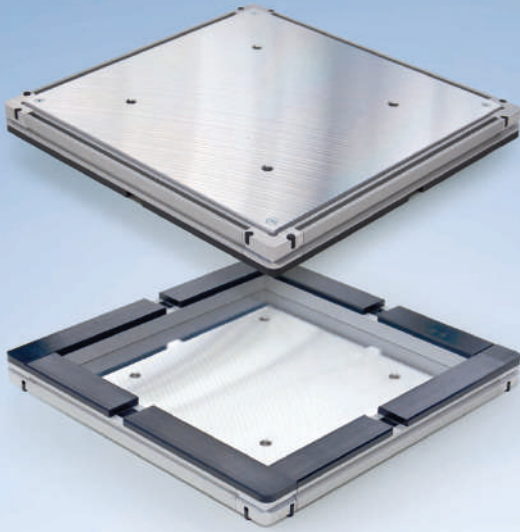

Accessories

Pallets

Pallets can be custom-configured to suit your specific application, whether they are delivered fully assembled or for self-assembly. The permitted total weight per pallet is determined by the total load capacity per metre of the system (100 kg/m). Please note that the clear width of the side rail must be 2 to 4 mm wider than the width of the pallet to guide the pallet in the optimal way.

Individual pallet components:

- Aluminium profile frame consisting of the profile mk 2260 and the corner pieces
- Plastic wear strips PE-1000 below the profile frame
- Support plates in varying thickness: 5, 6, 8, 10 and 12 mm
- Bumpers/rubber buffers
- Positioning sockets

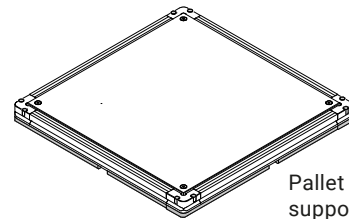
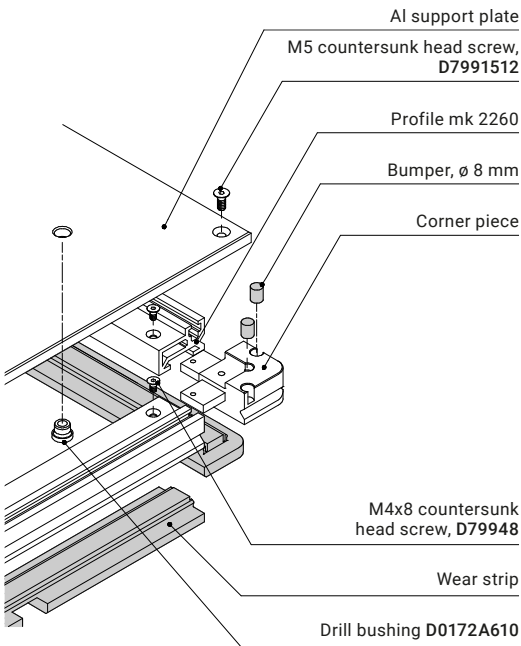

Pallet with support plate

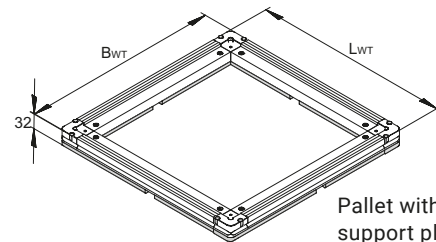

Pallet without support plate

W _{PT} mm	L _{PT} mm	Support plate mm	Weight _{PT} kg
400	400	8	5
400	600	8	8
600	600	10	14
600	800	10	16
800	800	12	24
800	1000	12	30

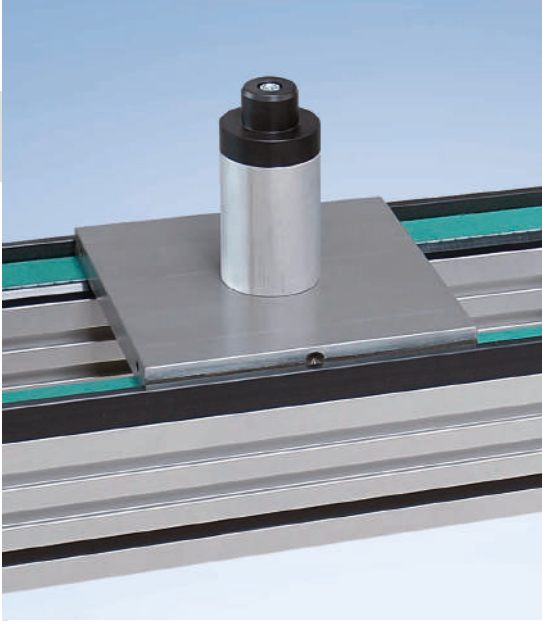

Pallets

Stopping and Separating

To stop or separate the pallets, the stoppers can be positioned at the centre or on the outside.

4

Centre of Gravity

The position of the product being transported must be taken into consideration to ensure that transport is smooth and as faultless as possible.

We recommend positioning the centre of gravity of the product being transported as close to the middle of the pallet as possible. In addition, the height of the centre of gravity should not be more than 0.5 times the shortest side length of the pallet.

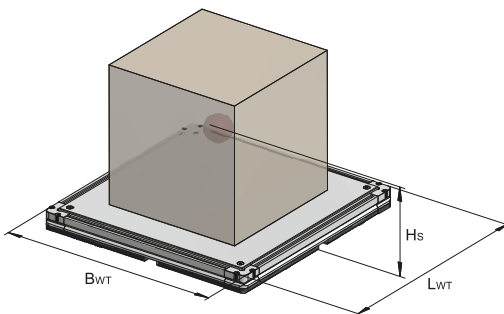

Central stop position

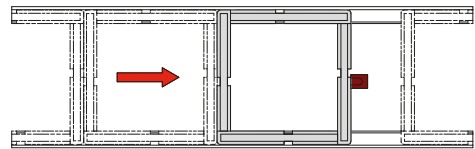
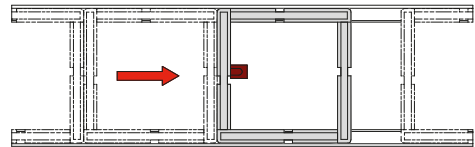

Outer stop position

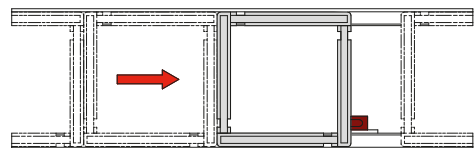
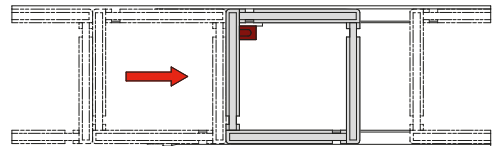



Accessories

SU – Stopper Undamped

Stoppers are used to stop or separate the pallets. The stopper variants are selected based on the conveyor weight and conveyor speed. Customers can choose between a variety of stroke heights based on their requirements. Damped or undamped stoppers can be connected in the centre or on the sides.

They can be requested through inductive (I) or electric (E) sensors.

Return Stop

The return stop is used in combination with a stopper in transfer systems with low belt friction and prevents pallets from recoiling/rebounding while stopping. The return stop is activated through a spring.

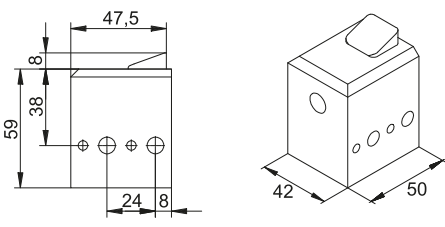

Return Stop
K503030101
 Lowering stroke: 8 mm

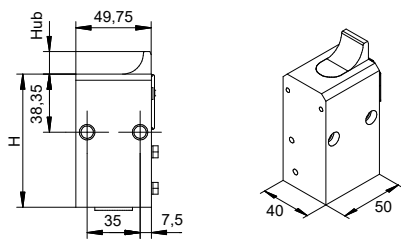

SU 400

SA=single-acting (locked in a depressurised state)

Ident. no.	Re-quest	Stroke (mm)	V=6	V=9	V=12	V=18
			m/min	m/min	m/min	m/min
			[kg]	[kg]	[kg]	[kg]
K503011401	E	9	400	300	250	200
K503011405	I	9	400	300	250	200
K503011404	-	9	400	300	250	200
K503011406	E	15	400	300	250	200
K503011402	-	15	400	300	250	200

DA=double-acting (maintains the last position reached)

K503012401	E	9	400	300	250	200
K503012404	-	9	400	300	250	200
K503012405	I	9	400	300	250	200



SD – Stopper Damped

Damped stopping allows you to gently slow down the first pallet. Damping prevents the workpiece from slipping in a certain location. Electrical or inductive sensors on the stoppers are optional. A minimum mass of 3 kg is required to ensure proper functioning. Damped or undamped stoppers can be connected in the centre or on the sides.

They can be requested through inductive (I) or electric (E) sensors.

4

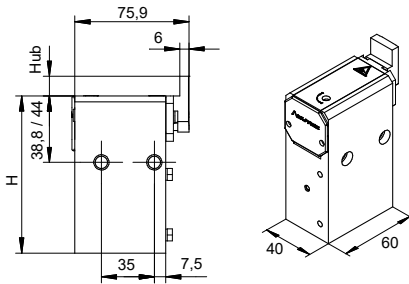

SD 60

SA=single-acting (locked in a depressurised state)

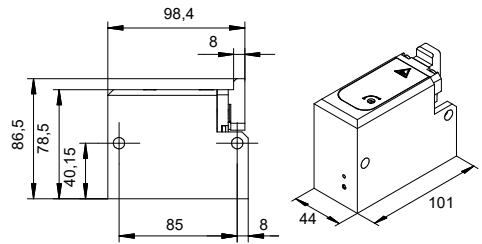

SD 100

SA=single-acting (locked in a depressurised state)

Ident. no.	Re-quest	Stroke (mm)	V=6	V=12	V=24	V=30
			m/min [kg]	m/min [kg]	m/min [kg]	m/min [kg]
K503021061	E	8	3-60	3-35	3-24	3-18
K503021063	-	8	3-60	3-35	3-24	3-18
K503021064	I	8	3-60	3-35	3-24	3-18

Ident. no.	Re-quest	Stroke (mm)	V=6	V=12	V=24	V=30
			m/min [kg]	m/min [kg]	m/min [kg]	m/min [kg]
K503021101	-	8	3-100	3-60	3-40	3-30
K503021102	I	8	3-100	3-60	3-40	3-30

DA=double-acting (maintains the last position reached)

K503022061	E	8	3-60	3-35	3-24	3-18
K503022063	-	9	3-60	3-35	3-24	3-18
K503022064	I	10	3-60	3-35	3-24	3-18

DA=double-acting (maintains the last position reached)

K503022101	-	8	3-100	3-60	3-40	3-30
K503022102	I	8	3-100	3-60	3-40	3-30

The specifications apply for a friction coefficient of $\mu = 0.07$
Stoppers for heavier loads available upon request

The specifications apply for a friction coefficient of $\mu = 0.07$
Stoppers for heavier loads available upon request

Application Examples



ZRF-P 2040, threaded sleeves integrated into the timing belt enable customer-specific cams to be bolted on

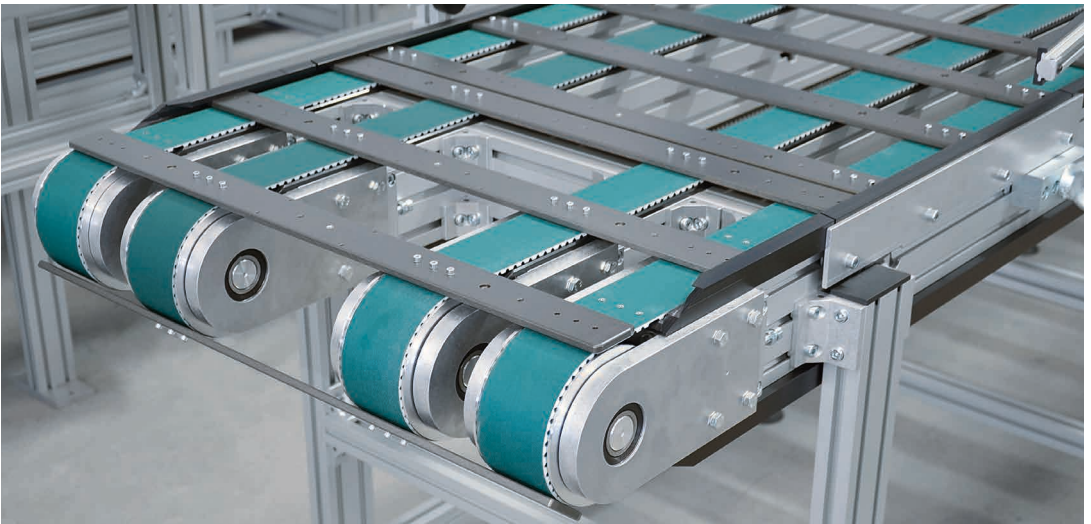

Four-line timing belt conveyor ZRF-P 2040 with bolted-on product holders

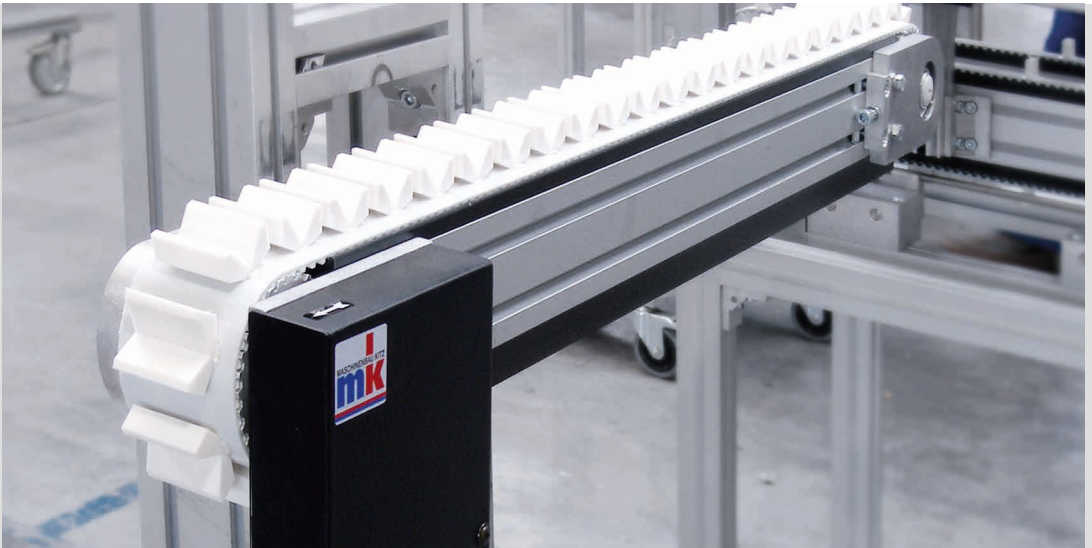

4

ZRF-P 2040 with drive AC and attached prisms for holding rods

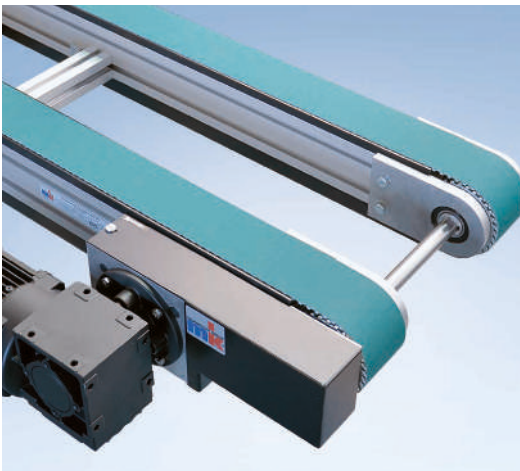

Dual timing belt conveyor
ZRF-P 2040 with head drive AS

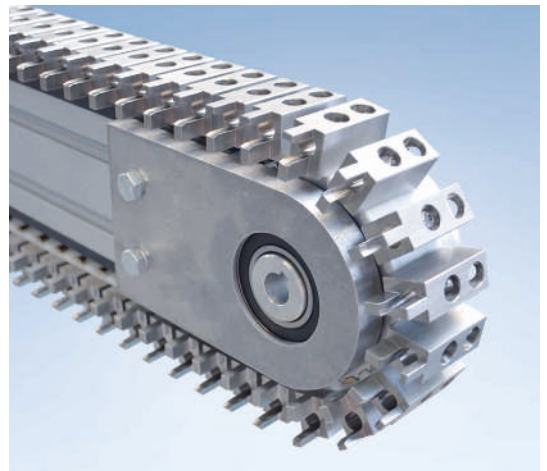

ZRF-P 2040 with VA steel insert frames bolted onto the timing belt for picking up the product

Application Examples

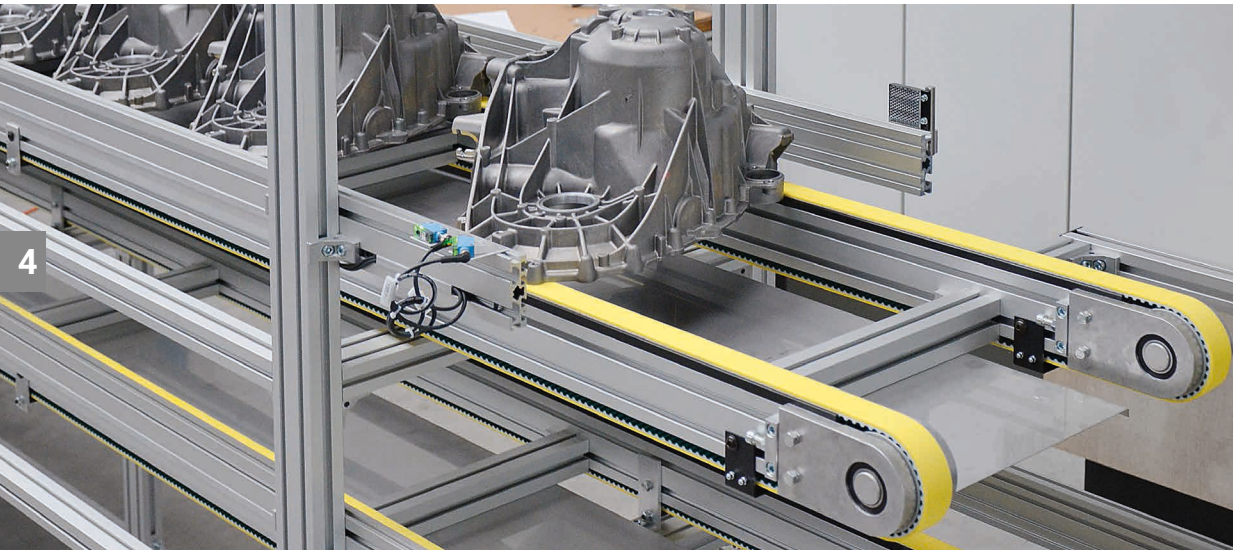

ZRF-P 2040 as feed system and storage system with side rail and controller

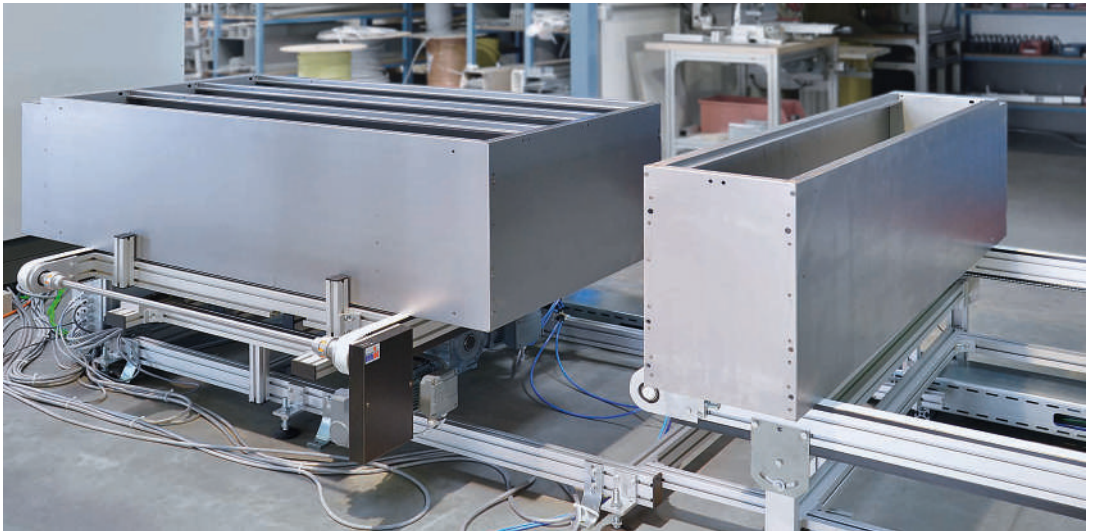

Interlink ZRF-P 2040 with lift and transfer for lockers

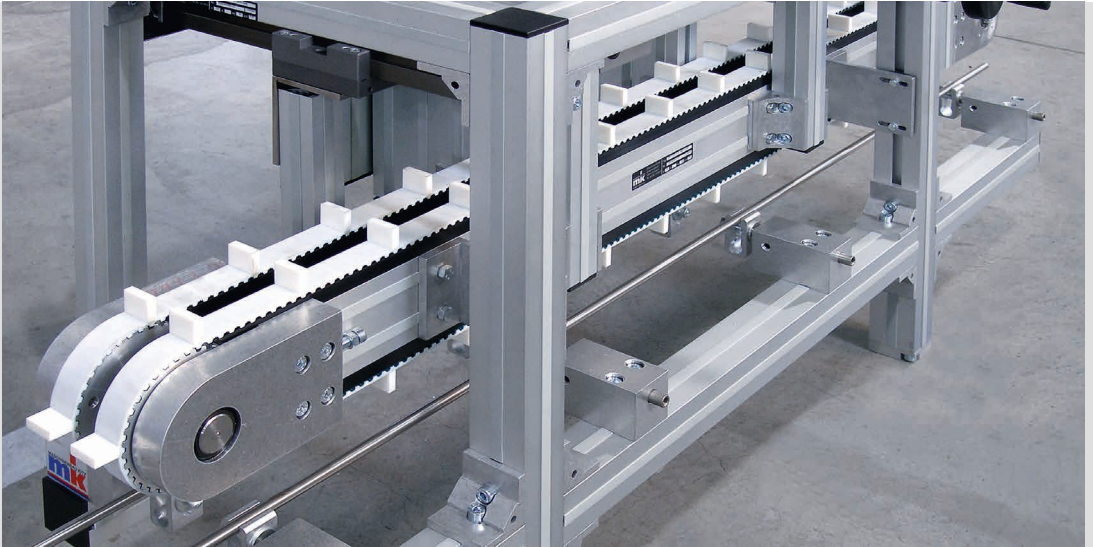

4

Width-adjustable dual timing belt conveyor with cleats

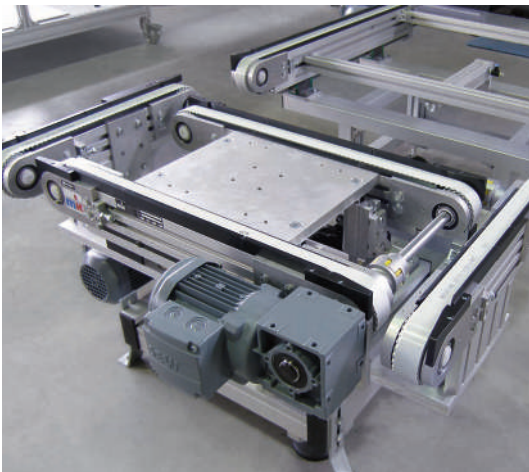

Lift and transfer with turn station
and pneumatic feed stroke

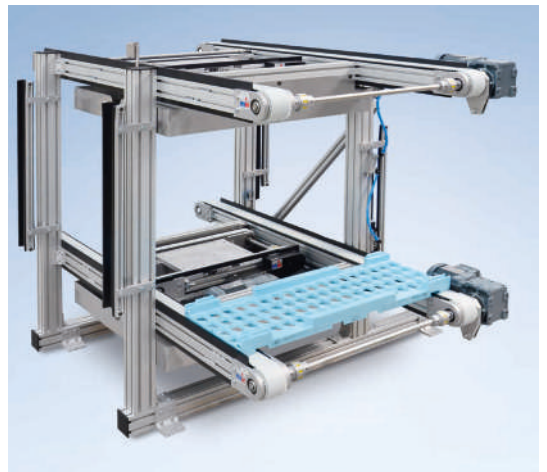

ZRF-P 2040 as channelling and
separating module with lift and transfer

Application Examples



ZRF-P 2010 with coupled lift and transfer conveyor



ZRF-P 2010 with drive BC and side rail



Timing belt conveyor with support frame and drip pan



4

Interlink ZRF-P 2010 as loading and unloading station for bread roll production with stacking unit as a buffer



ZRF-P 2010 with stopper/separator function and Makrolon cover as protective guard

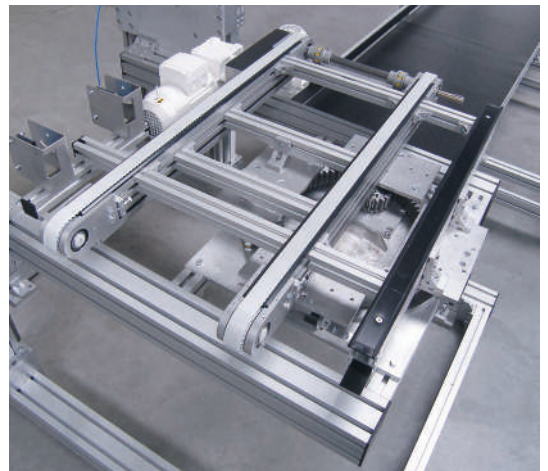

ZRF-P 2010 with head drive AS on rotary module (0/90/180/270°)

Chapter 5 Chain Conveyors

5



Selecting a Chain Conveyor

184

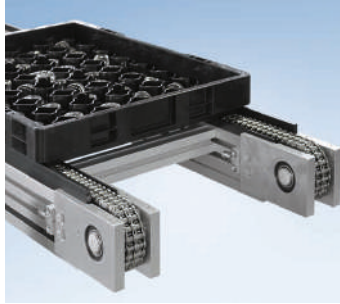

Chain Conveyor KTF-P 2010

186

- Head Drives 188
- Lower Run Drives 192
- Wear Strips 194

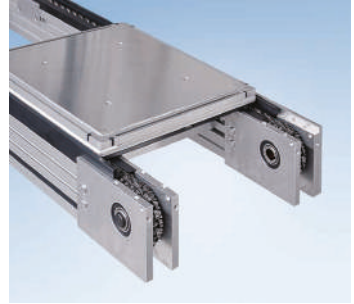

Accumulating Roller Chain Conveyor SRF-P 2010

196

- Head Drives 198
- Lower Run Drives 202
- Wear Strips 204

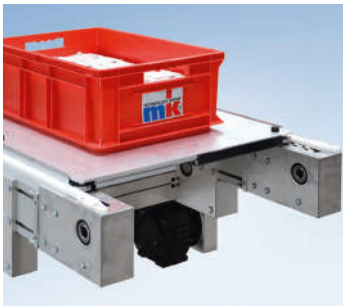

Accumulating Roller Chain Conveyor SRF-P 2012

206

- Head Drives 208
- Lower Run Drives 211
- Wear Strips 213

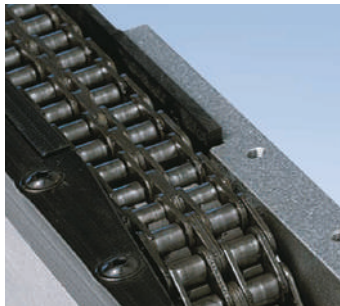

Chains

- For KTF-P 2010 214
- For SRF-P 2010 and SRF-P 2012 215

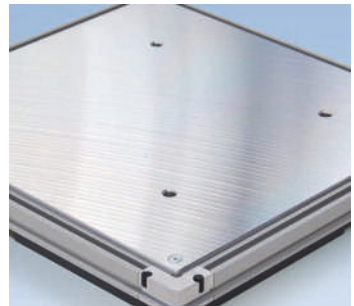

Accessories

- Pallets 216
- Maintenance Equipment 217
- SU – Stopper Undamped 218
- SD – Stopper Damped 219

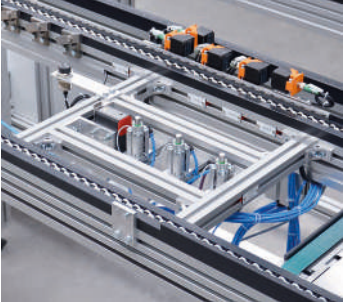

Application Examples 220

Selecting a Chain Conveyor

Dimensions – Technical Data

Conveyor system	Conveyor widths [mm]	Conveyor lengths [mm]	Total load* as standard, up to [kg]	Speed up to [m/min]	∅ of tails [mm]	Reverse operation	Accumulated operation	Cycling operation
Chain conveyor								
KTF-P 2010	200–2000	500–10000	500	30	approx. 90	•	•	•
Accumulating roller chain conveyor belt								
SRF-P 2010	200–2000	500–10000	500	30	approx. 90			•
SRF-P 2012	200–2000	1000–10000	1000	30	approx. 90	•		

*Maximum load that is transported by the system in question with a standard configuration and for a standard application. The permissible load depends on the width, chain type, load distribution, operating mode and environmental influences.

Selecting Double-line Conveyors based on Load and Speed

The diagram shows double-line conveyor systems based on their load and speed. The comparison shows timing belt conveyors (ZRF), chain conveyors (KTF) and accumulating roller chain conveyors (SRF).

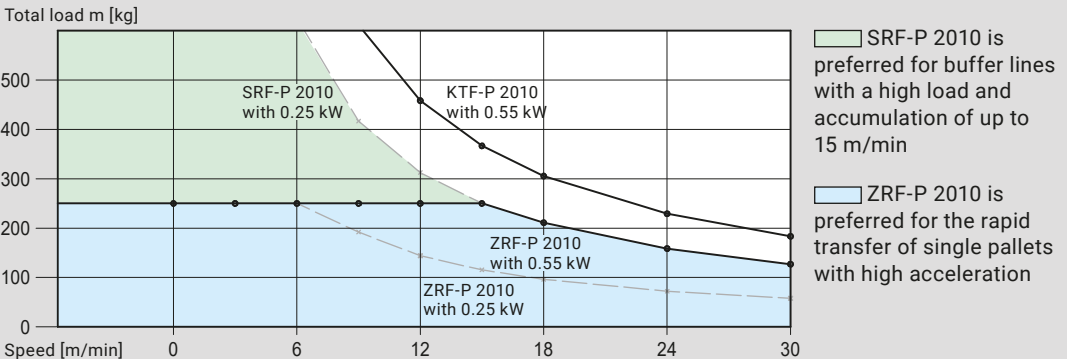

Total load m [kg] per conveying path, per drive in continuous operation (accumulated operation $m_{\text{accumulated}} = 2 \times m_{\text{continuous}}$)

Selecting the Stopper

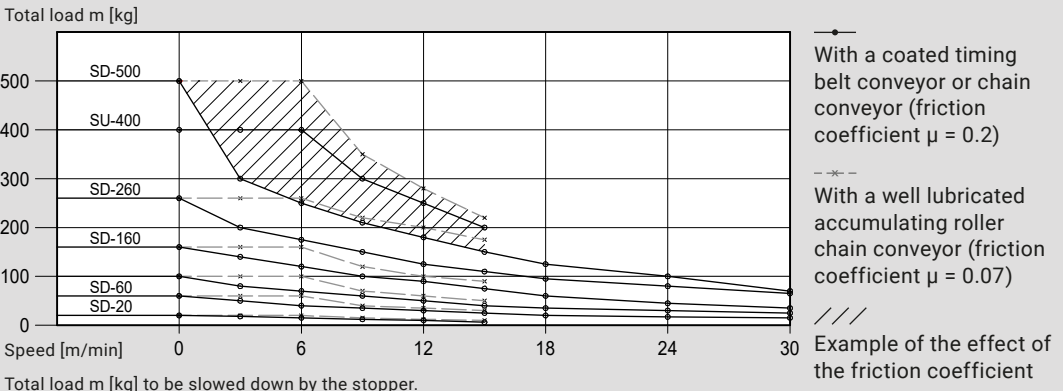

Application Options

Chain conveyors are ideal for the cycled transport of products. Available with different drive variants, they are often used for setting up complex interlinking solutions. They are typically used for transferring pallets with high loads and even speeds in a double-line area. For high speeds or positioning tasks, low-maintenance and low-noise timing belt conveyors are used (see the image on the left and the previous chapter). Various chain types in combination with our sturdy, solid wear strips ensure reliable, long-term functioning that is optimally suited to your application.

The **chain conveyor KTF-P 2010** is primarily used as the basic element for constructing transfer lines. It is available as a single, dual or multiple line system with either a simple roller chain or a duplex roller chain for higher loads and a larger support surface.

The **accumulating roller chain conveyor SRF-P 2010** is also based on the profile mk 2010 and is suitable for accumulated operation. The conveyor is therefore ideal for interlinking and buffering between workstations. Like all chain conveyors, the system can be equipped with an optional tensioning device and continuous lubrication device.

The design of our **accumulating roller chain conveyor SRF-P 2012** for the heavier load range of up to 1000 kg ensures smooth operation thanks to the free-spinning conveyor rollers, even during accumulated operation. The accumulation force is kept to a minimum. Typical applications for this chain conveyor include interlinking workstations or buffering between workstations and assembly stations.

Chains

The chains used (see page 202) are available in various designs to ensure optimal function in your specific application. Our standard product range includes a single roller chain and a duplex roller chain. The duplex chain can convey higher loads and offers a larger contact surface.

Accumulating roller chains with either plastic or steel rollers are available for accumulated operation. Plastic rollers produce less noise and require less maintenance than steel rollers, but they are not suitable for environments with sustained temperatures above 60° C, in painting applications or in potentially explosive atmospheres. When using steel rollers, note that plastic wear strips (PE or POM) must be attached to the contact surfaces on the pallets to be transported.

The accumulating roller chain is available with accumulating rollers in rows one behind the other (more robust with higher breaking resistance) or accumulating rollers that are offset from each other. The offset accumulating rollers offer more contact points and therefore smoother operation as well as a higher max. load for the line. These chains can also be equipped with a finger guard in accordance with the German accident prevention regulations (UVV).

In contrast to timing belts, chains must always be well lubricated. They can be used in temperatures up to 60° C or up to 120° C. Higher temperatures can be achieved on request. Low-maintenance chains are also available as an option.

Chain Conveyor KTF-P 2010



» For transporting heavier loads even in harsh environments. «

The KTF-P 2010 chain conveyor is a conveyor system for moderate loads and is ideally suited for transporting pallets. Its large selection of drives makes it extremely flexible, and it is normally used as the basis for constructing transfer lines.

It is available as a single, dual or multiple line system with either a simple roller chain or a duplex roller chain for higher loads and a larger support surface. The various chains and wear strip guides allow the workpiece to be optimally placed on the conveyor, while their excellent anti-frictional properties make them extremely low maintenance and sturdy.

Longitudinal slots in the mk 2010 profile beam provide flexible options for connecting struts, guides, initiators and components from the mk profile system. Like all chain conveyors, the system can be equipped with an optional tensioning device and continuous lubrication device.

Benefits of the KTF-P 2010

- Basis for constructing transfer systems for higher loads
- Ideal as a dual or multiple line system for transporting pallets
- Large selection of drives
- Low-maintenance and sturdy use in cycling operation
- Suitable for dirty and oily environments

Cross Section

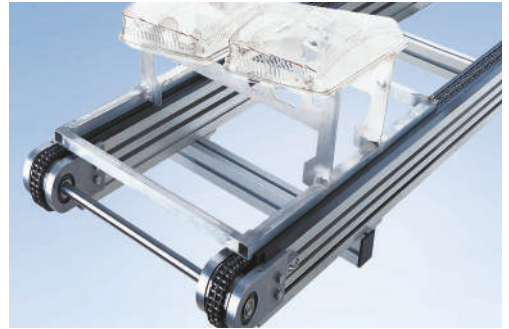
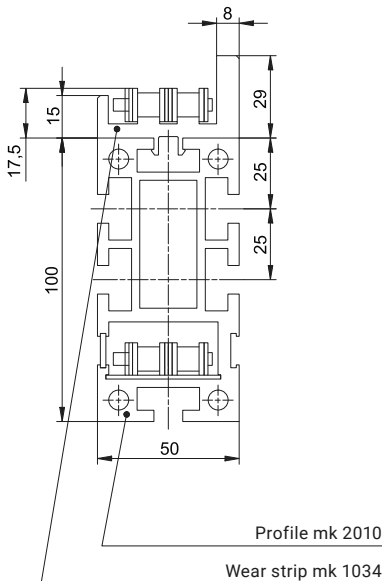

Properties

The drive variant AA without a motor offers the advantage of operating multiple conveyor lines in parallel or in series with one drive. Depending on your requirements, the conveyor is designed either with a hollow shaft or with a connecting shaft with shaft journal. Operation with cleats is not possible with this version.

B20.10.465

5



For information about wear strip variants, see page 194 onwards

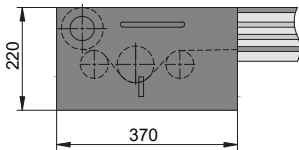

Available with optional tensioning device and lubrication station (see page 217)

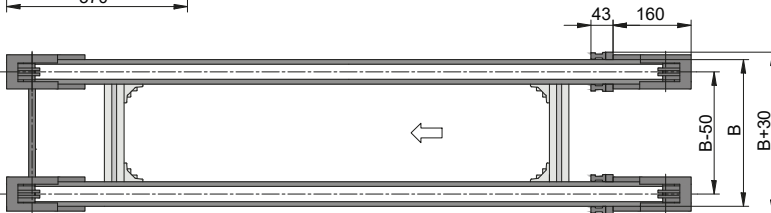

Technical data

Conveyor length L	individual from 500 to 10000 mm	
Conveyor width B	200 to 2000 mm	
Chains	1/2" single or duplex	p. 214
Drive and speed	up to 30 m/min	p. 12
Stand and side rail		from p. 280
Standard total load	up to 500 kg	up to 1000 kg on request
Standard distributed load	up to 150 kg/m (with duplex chain)	



Properties

The sprocket ensures excellent transmission of the motor power. Operation with cleats is not possible with this version.

B20.10.466

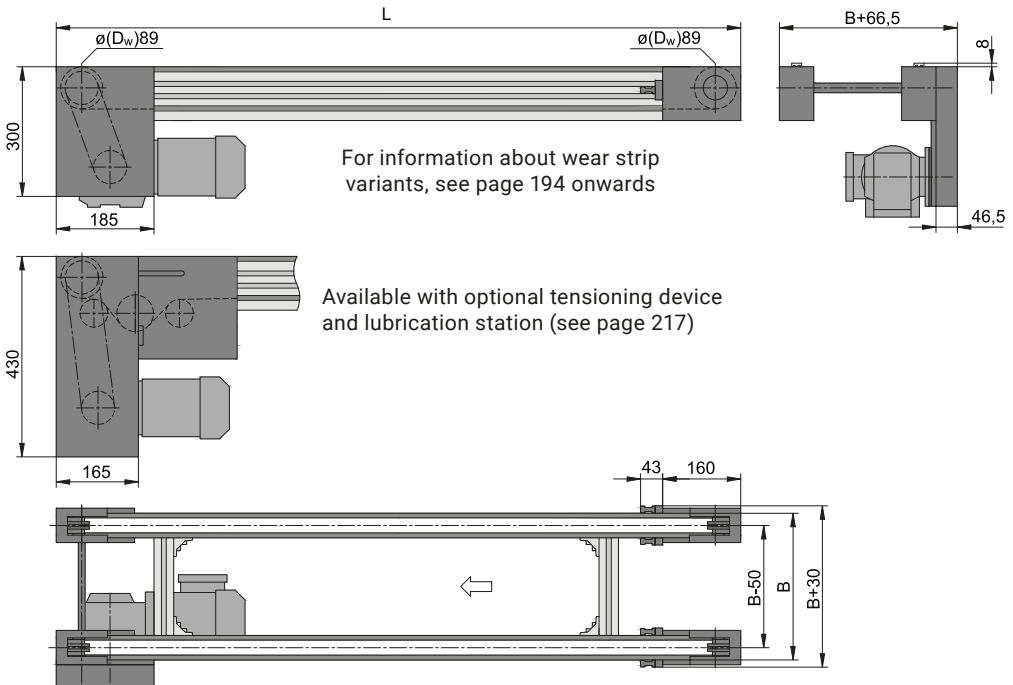

Technical data

Conveyor length L	individual from 500 to 10000 mm	
Conveyor width B	200 to 2000 mm	
Chains	1/2" single or duplex	p. 214
Drive location	discharge end left/right, underneath	
Drive and speed	up to 30 m/min	p. 12
Stand and side rail		from p. 280
Standard total load	up to 500 kg	up to 1000 kg
Standard distributed load	up to 150 kg/m (with duplex chain)	on request

Properties

Since the motor is fitted directly onto the drive shaft, the space requirements and maintenance effort for this drive version are reduced to a minimum. Operation with cleats is not possible with this version.

B20.10.467

5

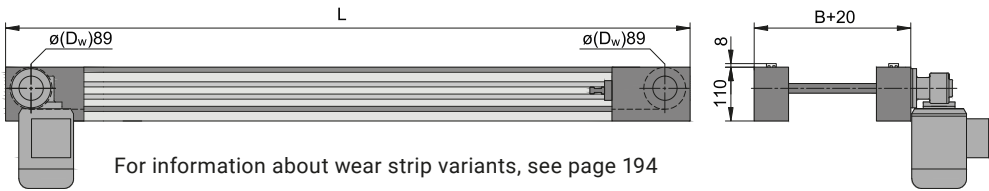

For information about wear strip variants, see page 194

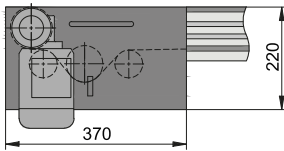

Available with optional tensioning device and lubrication station (see page 217)

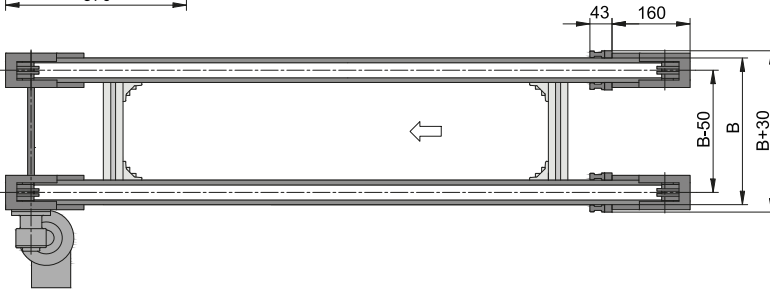

Technical data

Conveyor length L	individual from 500 to 10000 mm	
Conveyor width B	200 to 2000 mm	
Chains	1/2" single or duplex	p. 214
Drive location	discharge end left/right, underneath	
Drive and speed	up to 30 m/min	p. 12
Stand and side rail		from p. 280
Standard total load	up to 500 kg	up to 1000 kg on request
Standard distributed load	up to 150 kg/m (with duplex chain)	



Properties

The drive positioned laterally on the outside allows the total height of the conveyor to be restricted to a minimum. Operation with cleats is not possible with this version.

B20.10.468

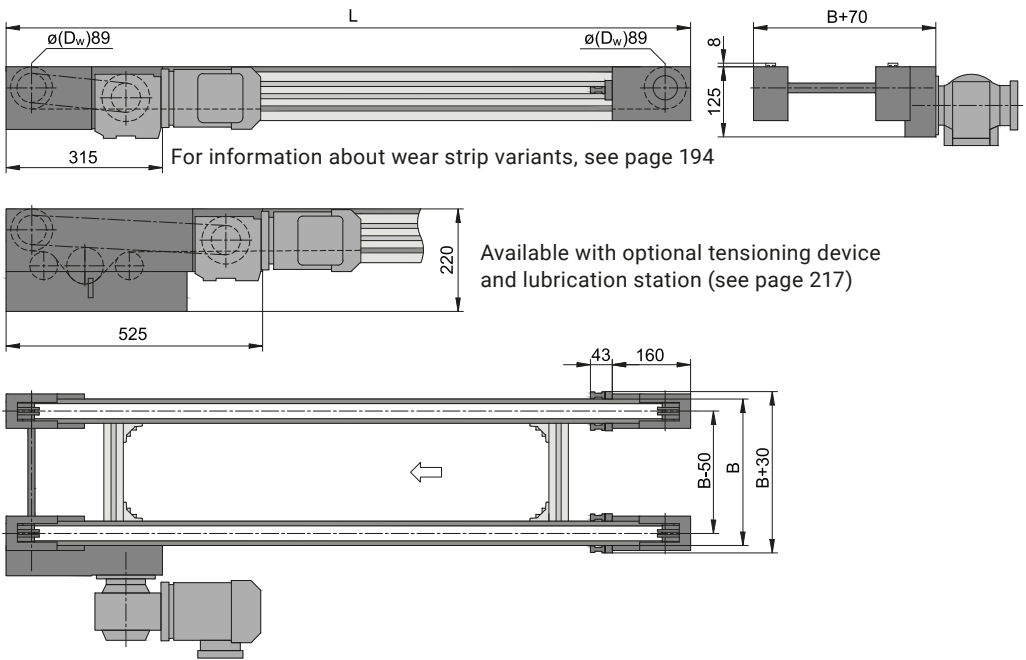

Technical data

Conveyor length L	individual from 700 to 10000 mm	
Conveyor width B	200 to 2000 mm	
Chains	1/2" single or duplex	p. 214
Drive location	discharge end left/right	
Drive and speed	up to 30 m/min	p. 12
Stand and side rail		from p. 280
Standard total load	up to 500 kg	up to 1000 kg on request
Standard distributed load	up to 150 kg/m (with duplex chain)	

Properties

The compact conveyor frame design and the ability to freely select the drive position over the entire length of the conveyor make it easier to integrate the conveyor into existing systems. The drive sprocket wheel ensures excellent transmission of the motor power. Operation with cleats is not possible with this version.

B20.10.471

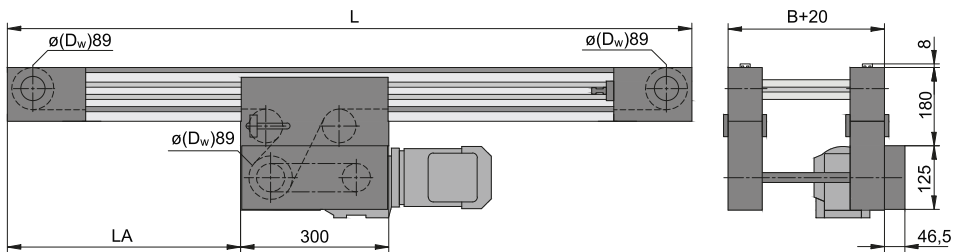

For information about wear strip variants, see page 194 onwards

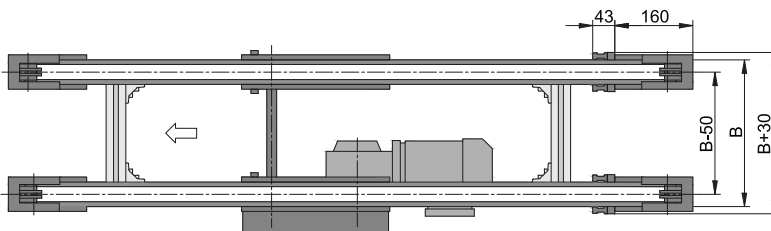

Technical data

Conveyor length L	individual from 700 to 10000 mm	
Conveyor width B	200 to 2000 mm	
Chains	1/2" single or duplex	p. 214
Drive location	left/right underneath	
Drive and speed	up to 30 m/min	p. 12
Stand and side rail		from p. 280
Standard total load	up to 500 kg	up to 1000 kg on request
Standard distributed load	up to 150 kg/m (with duplex chain)	



Properties

Since the motor is fitted directly onto the drive shaft, the space requirements and maintenance effort for this drive version are reduced to a minimum. The compact conveyor frame design and the ability to freely select the drive position anywhere along the entire length of the conveyor make it easier to integrate the conveyor into existing systems. The conveying direction is reversible. Operation with cleats is not possible with this version.

B20.10.472

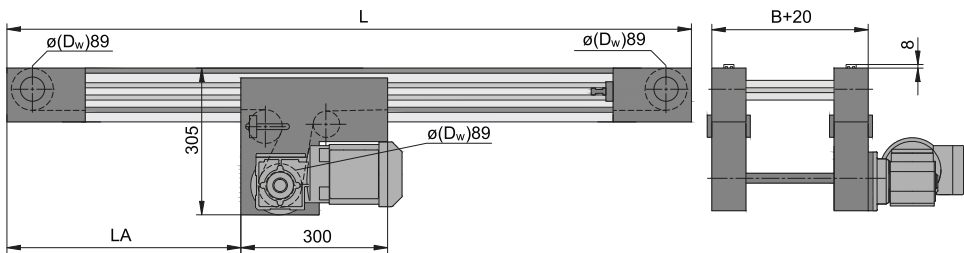

For information about wear strip variants, see page 194 onwards

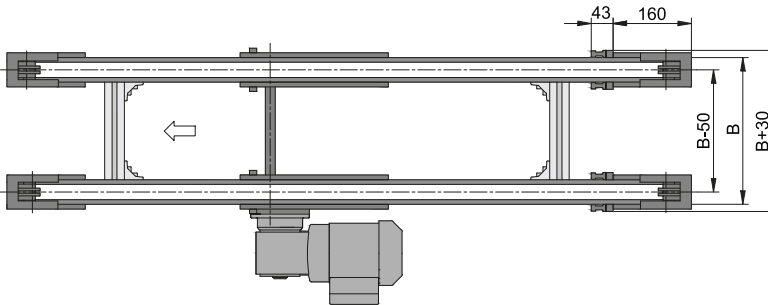

Technical data

Conveyor length L	individual from 700 to 10000 mm	
Conveyor width B	200 to 2000 mm	
Chains	1/2" single or duplex	p. 214
Drive location	left/right underneath	
Drive and speed	5; 6.3; 8; 9.5; 11.5; 13.5; 15.2; 19.3; 23; 26; 36.6; 45.7 and 57 m/min	p. 12
Stand and side rail		from p. 280
Standard total load	up to 500 kg	up to 1000 kg on request
Standard distributed load	up to 150 kg/m (with duplex chain)	

KTF-P 2010 Wear Strips

Wear and guide strips from mk ensure low friction.
The wear strips are made from PE-UHMW (PE-1000). Max. temperature of 65° C.

Variant A

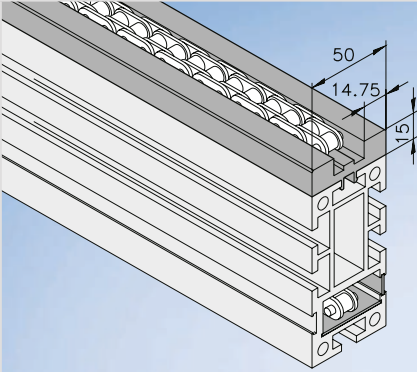

Top wear strip mk 1037
22.37.2000

Bottom wear strip
21.14.0001

Closure strip
K10230/12

Variant B

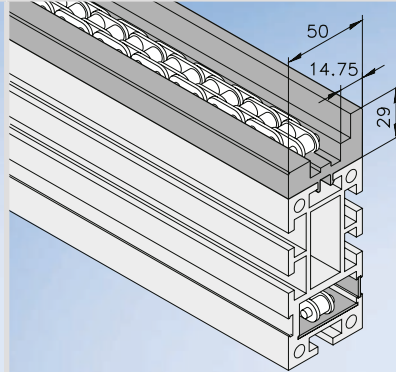

Top wear strip mk 1038
22.38.2000

Bottom wear strip
21.14.0001

Closure strip
K10230/12

Variant C

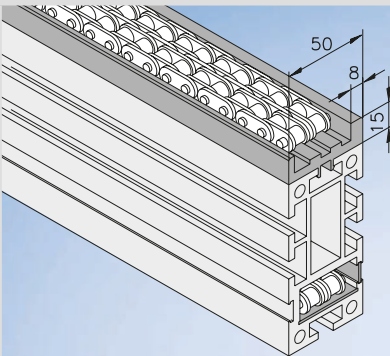

Top wear strip mk 1033
22.33.2000

Bottom wear strip
21.14.0001

Closure strip
K10230/12

Variant D

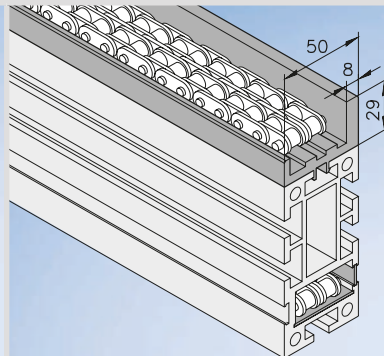

Top wear strip mk 1034
22.34.2000

Bottom wear strip
21.14.0001

Closure strip
K10230/12

5

Variant E

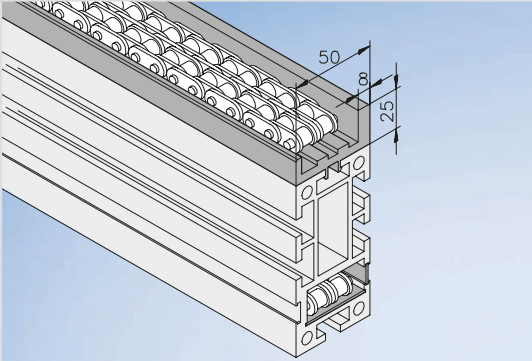

Top wear strip mk 1111
23.11.2000

Bottom wear strip
21.14.0001

Closure strip
K10230/12

Accumulating Roller Chain Conveyor SRF-P 2010



» For transporting and buffering pallets with high loads. «

The SRF-P 2010 accumulating roller chain conveyor is intended as the basis for constructing transfer lines for loads up to 500 kg. The freespinning conveyor rollers run smoothly, even during accumulated operation. They also keep accumulation forces to a minimum. Typical applications include interlinking or buffering between workstations and building complete transfer lines.

Longitudinal slots in the mk 2010 profile beam provide flexible options for connecting struts, guides, initiators and components from the mk profile system. Like all chain conveyors, the system can be equipped with an optional tensioning device and continuous lubrication device.

The wear and guide strips that support and guide the timing belt are made from ultra-high-molecular weight polyethylene (PE-UHMW), and provide a low friction coefficient with excellent wear characteristics over a wide temperature range (up to 65° C over extended periods).

Benefits of the SRF-P 2010

- Basis for constructing transfer lines with accumulated operation
- Ideal for low-maintenance and durable use in accumulated and cycling operation
- For interlinking and buffering between workstations and for transporting pallets
- Large selection of drives
- Suitable for dirty and oily environments

Cross Section

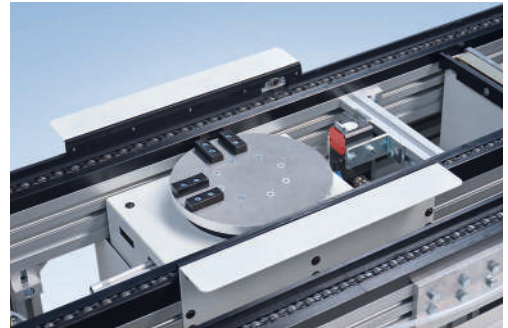
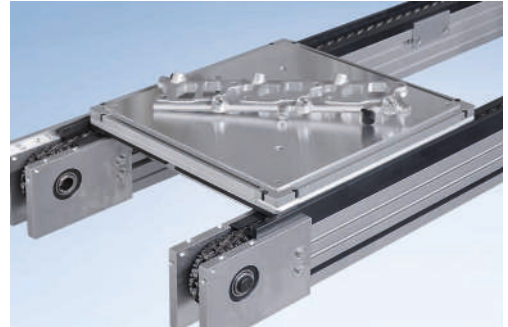
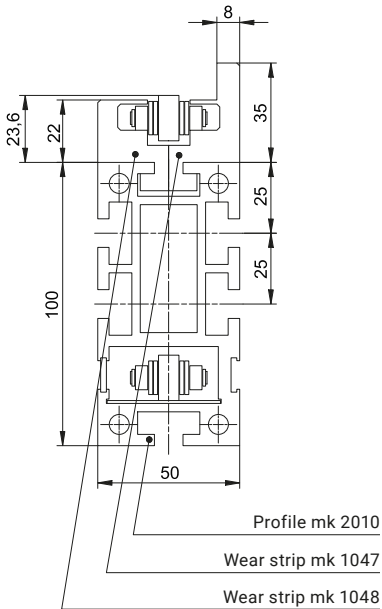

Properties

The drive variant AA without a motor offers the advantage of operating multiple conveyor lines in parallel or in series with one drive. Depending on the requirement, the conveyor is designed either with a hollow shaft or with a connecting shaft with shaft journal ($\varnothing 20$ mm, usable length 34 mm, incl. DIN 6885 key)

B20.10.565

5

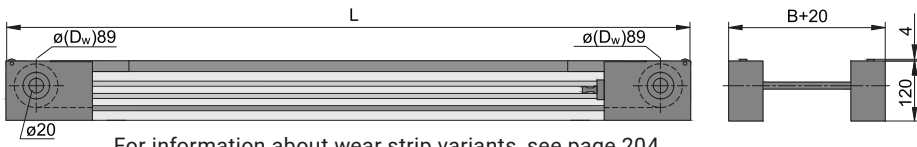

For information about wear strip variants, see page 204

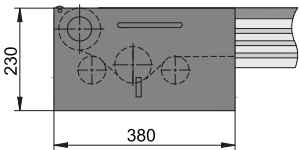

Available with optional tensioning device and lubrication station (see page 217)

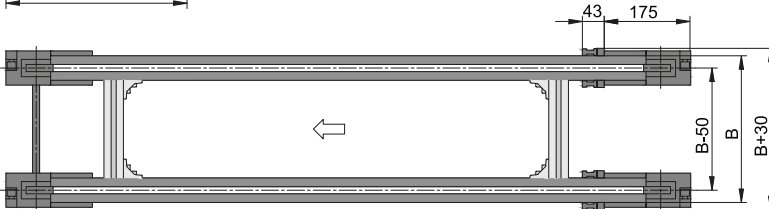

Technical data

Conveyor length L	individual from 730 to 10000 mm	
Conveyor width B	200 to 2000 mm	
Chains	1/2" accumulating roller chain with plastic or steel rollers	p. 215
Drive and speed	up to 30 m/min	p. 12
Stand and side rail		from p. 280
Standard total load	up to 500 kg (750 kg without accumulated operation)	higher on request
Standard distributed load	up to 100 kg/m (in series) up to 150 kg/m (offset)	



Properties

The sprocket ensures excellent transmission of the motor power.

B20.10.566

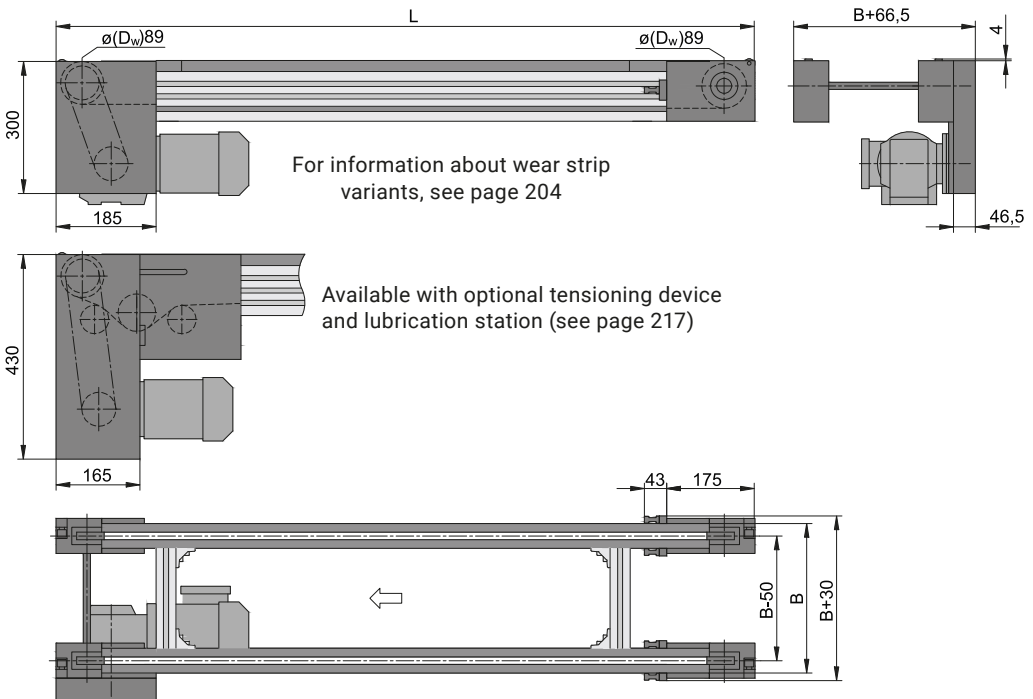

Technical data

Conveyor length L	individual from 730 to 10000 mm	
Conveyor width B	200 to 2000 mm	
Chains	1/2" accumulating roller chain with plastic or steel rollers	p. 215
Drive location	discharge end left/right, underneath	
Drive and speed	up to 30 m/min	p. 12
Stand and side rail		from p. 280
Standard total load	up to 500 kg (750 kg without accumulated operation)	higher on request
Standard distributed load	up to 100 kg/m (in series) up to 150 kg/m (offset)	

Properties

Since the motor is fitted directly onto the drive shaft, the space requirements and maintenance effort for this drive version are reduced to a minimum.

B20.10.567

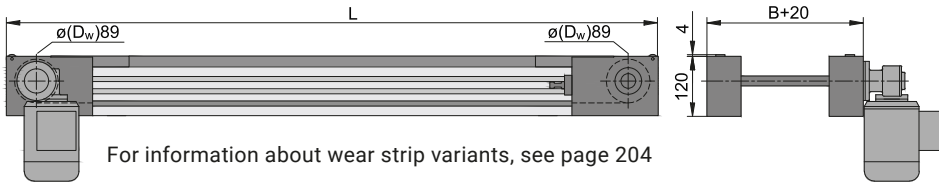

For information about wear strip variants, see page 204

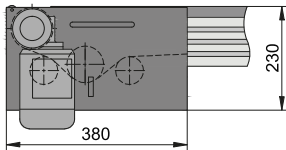

Available with optional tensioning device and lubrication station (see page 217)

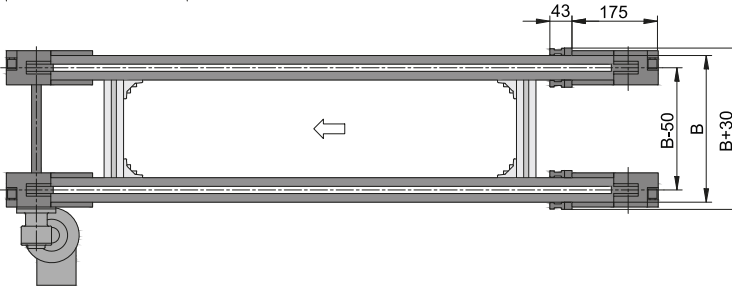

Technical data

Conveyor length L	individual from 730 to 10000 mm	
Conveyor width B	200 to 2000 mm	
Chains	1/2" accumulating roller chain with plastic or steel rollers	p. 215
Drive location	discharge end left/right	
Drive and speed	up to 30 m/min	p. 12
Stand and side rail		from p. 280
Standard total load	up to 500 kg (750 kg without accumulated operation)	higher on request
Standard distributed load	up to 100 kg/m (in series) up to 150 kg/m (offset)	



Properties

The drive positioned laterally on the outside allows the total height of the conveyor to be restricted to a minimum.

B20.10.568

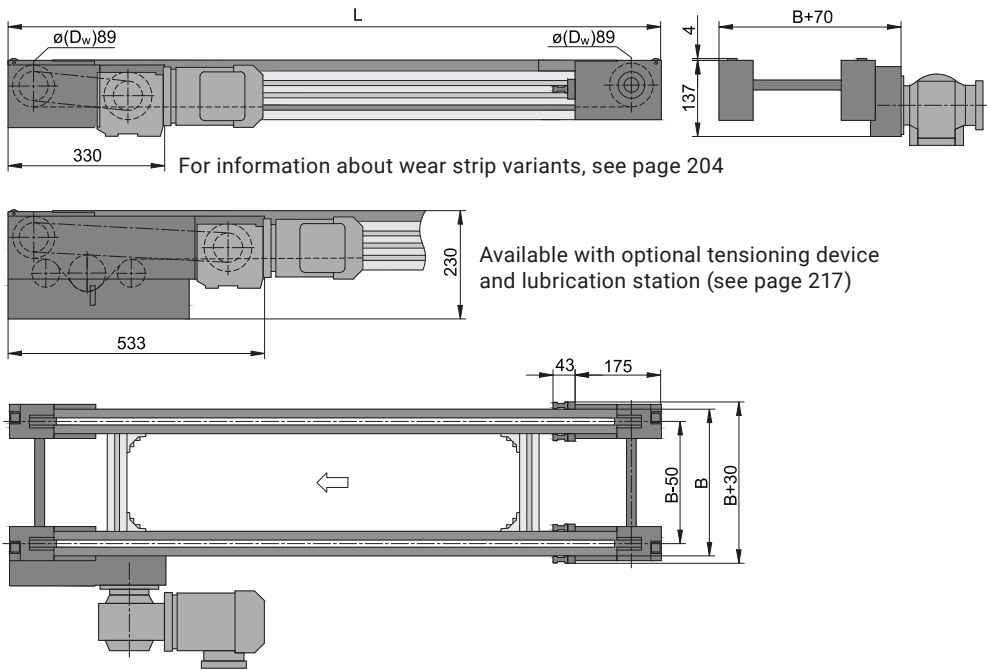

Technical data

Conveyor length L	individual from 730 to 10000 mm	
Conveyor width B	200 to 2000 mm	
Chains	1/2" accumulating roller chain with plastic or steel rollers	p. 215
Drive location	discharge end left/right	
Drive and speed	up to 30 m/min	p. 12
Stand and side rail		from p. 280
Standard total load	up to 500 kg (750 kg without accumulated operation)	higher on request
Standard distributed load	up to 100 kg/m (in series) up to 150 kg/m (offset)	

Properties

The compact conveyor frame design and the ability to freely select the drive position over the entire length of the conveyor make it easier to integrate the conveyor into existing systems. The drive sprocket wheel ensures excellent transmission of the motor power.

B20.10.571

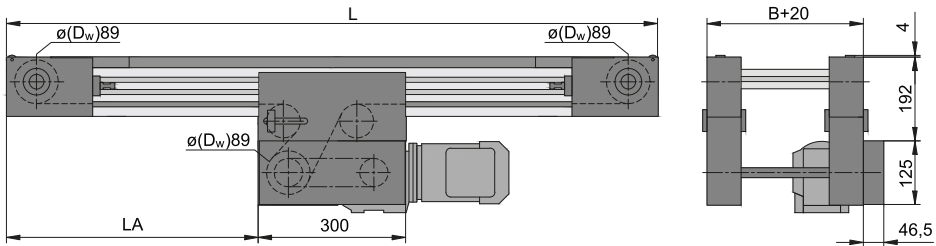

For information about wear strip variants, see page 204

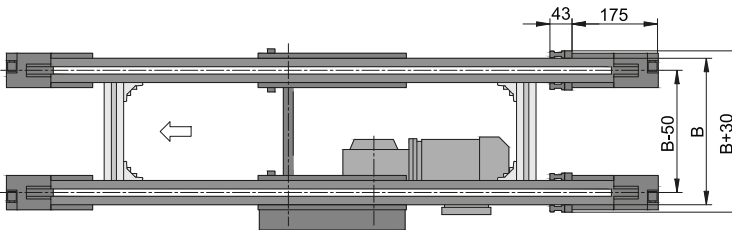

Technical data

Conveyor length L	individual from 730 to 10000 mm	
Conveyor width B	200 to 2000 mm	
Chains	1/2" accumulating roller chain with plastic or steel rollers	p. 215
Drive location	left/right underneath	
Drive and speed	up to 30 m/min	p. 12
Stand and side rail		from p. 280
Standard total load	up to 500 kg (750 kg without accumulated operation)	higher on request
Standard distributed load	up to 100 kg/m (in series) up to 150 kg/m (offset)	



Properties

Since the motor is fitted directly onto the drive shaft, the space requirements and maintenance effort for this drive version are reduced to a minimum. The compact conveyor frame design and the ability to freely select the drive position anywhere along the entire length of the conveyor make it easier to integrate the conveyor into existing systems. The conveying direction is reversible. Operation with cleats is not possible with this version.

B20.10.572

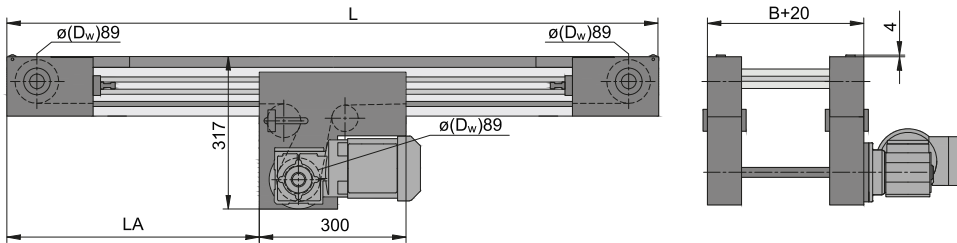

For information about wear strip variants, see page 204

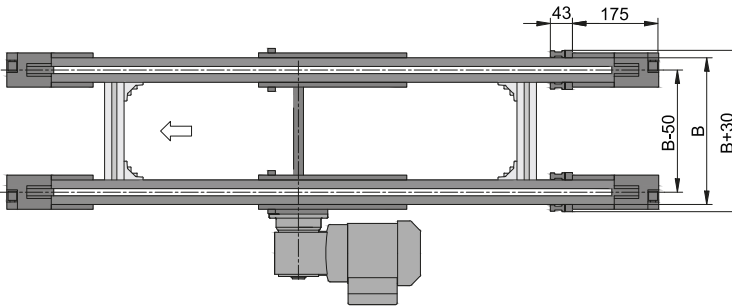

Technical data

Conveyor length L	individual from 730 to 10000 mm	
Conveyor width B	200 to 2000 mm	
Chains	1/2" accumulating roller chain with plastic or steel rollers	p. 215
Drive location	left/right underneath	
Drive and speed	5; 6.3; 8; 9.5; 11.5; 13.5; 15.2; 19.3; 23; 26; 36.6; 45.7 and 57 m/min	p. 12
Stand and side rail		from p. 280
Standard total load	up to 500 kg (750 kg without accumulated operation)	higher on request
Standard distributed load	up to 100 kg/m (in series) up to 150 kg/m (offset)	

SRF-P 2010 Wear Strips

Wear and guide strips from mk ensure low friction.
The wear strips are made from PE-UHMW (PE-1000). Max. temperature of 65° C.

Variant A

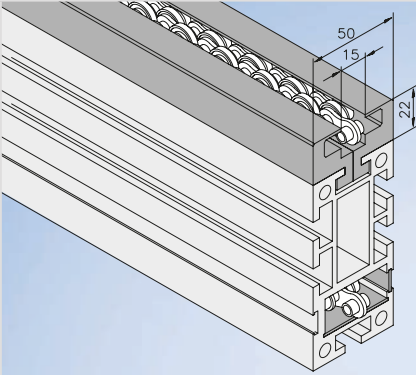

Top wear strip mk 1048
22.48.2000

Bottom wear strip
21.14.0001

Closure strip
K10230/12

Variant B

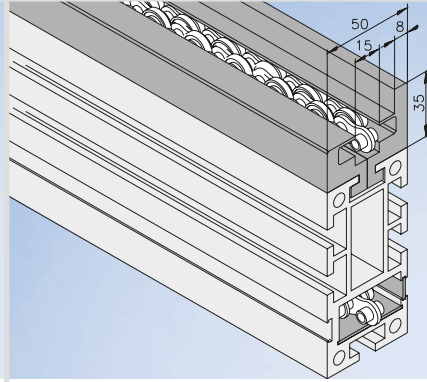

Top right wear strip mk 1047
22.47.2000

Top left wear strip mk 1048
22.48.2000

Bottom wear strip
21.14.0001

Closure strip
K10230/12

Variant C

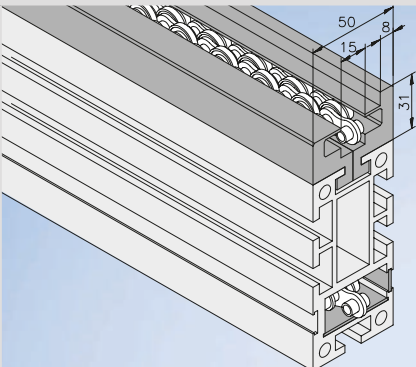

Top wear strip mk 1112
23.12.2000

Bottom wear strip
21.14.0001

Closure strip
K10230/12



Accumulating Roller Chain Conveyor SRF-P 2012

5



» For feeding and buffering in heavy load ranges. «

The SRF-P 2012 accumulating roller chain conveyor is intended as the basis for constructing transfer lines for loads up to 1000 kg. The freespinning conveyor rollers run smoothly, even during accumulated operation. They also keep accumulation forces to a minimum. Typical applications include interlinking or buffering between workstations and building complete transfer lines.

Longitudinal slots in the mk 2012 profile beam provide flexible options for connecting struts, guides, initiators and components from the mk profile system. Like all chain conveyors, the system can be equipped with an optional tensioning device and continuous lubrication device to extend the service intervals.

The wear and guide strips that support and guide the timing belt are made from ultra-high-molecular weight polyethylene (PE-UHMW), and provide a low friction coefficient with excellent wear characteristics over a wide temperature range (up to 65° C over extended periods).

Benefits of the SRF-P 2012

- Cycled transport of piece goods, either conventional or orientated
- Precise conveying, feeding and positioning up to 250 kg
- Available as a single, double or multiple line conveyor
- Various belt coatings for optimal gripping of the workpiece
- Ribs can be attached to hold the workpieces
- Suitable for dirty and oily environments

Cross Section

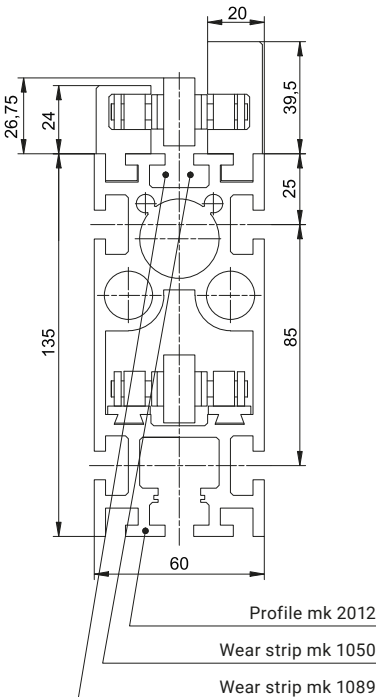

Properties

The AA drive variant offers the benefit of operating multiple conveyor lines in parallel or in series with one drive. Depending on your requirements, the conveyor is designed either with a hollow shaft or with a connecting shaft with shaft journal ($\varnothing 20/25$ mm, usable length of 40 mm, includes DIN 6885 key).

B20.12.008

5

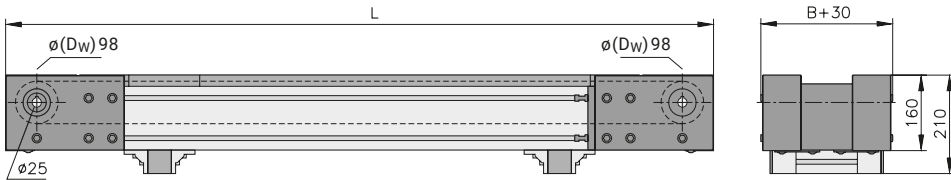

For information about wear strip variants, see page 213

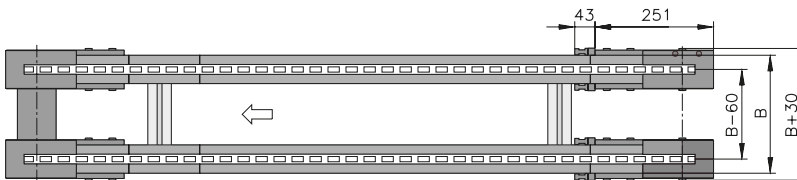

Technical data

Conveyor length L	individual from 1000–10000 mm (note the chain pitch)	
Conveyor width B	200 to 2000 mm	
Chains	3/4" accumulating roller chain with plastic or steel rollers	p. 215
Drive and speed	up to 30 m/min	p. 12
Stand and side rail		from p. 280
Standard total load	up to 1000 kg	higher on request
Standard distributed load	up to 150 kg/m	



Properties

The sprocket ensures excellent transmission of the motor power.

B20.12.007

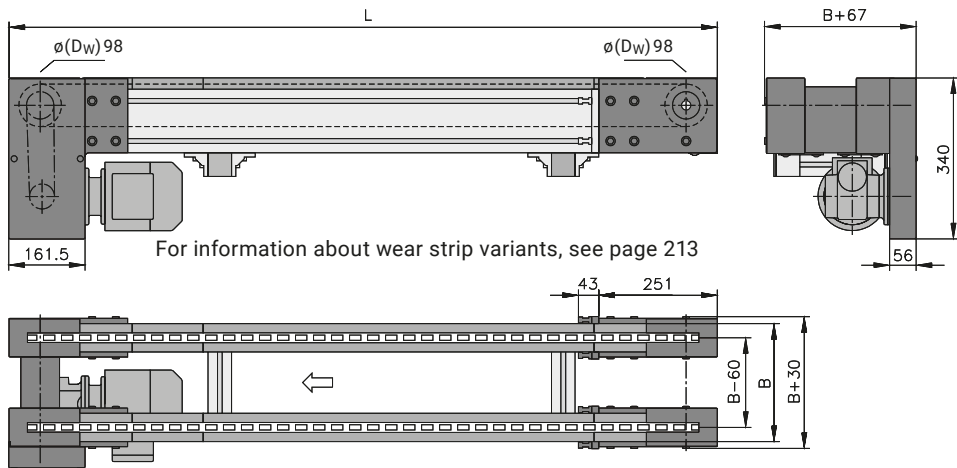

Technical data

Conveyor length L	individual from 1000–10000 mm (note the chain pitch)	
Conveyor width B	200 to 2000 mm	
Chains	3/4" accumulating roller chain with plastic or steel rollers	p. 215
Drive location	discharge end left/right, underneath	
Drive and speed	up to 30 m/min	p. 12
Stand and side rail		from p. 280
Standard total load	up to 1000 kg	higher on request
Standard distributed load	up to 150 kg/m	

Properties

The drive positioned laterally on the outside allows the total height of the conveyor to be restricted to a minimum.

B20.12.009

5

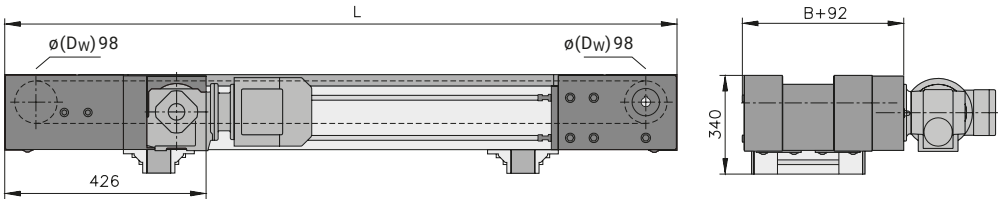

For information about wear strip variants, see page 213

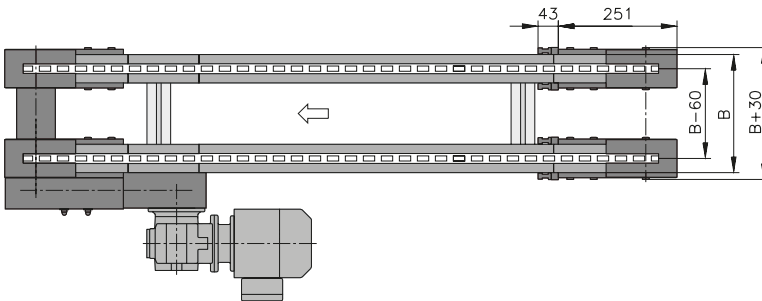

Technical data

Conveyor length L	individual from 1000–10000 mm (note the chain pitch)	
Conveyor width B	200 to 2000 mm	
Chains	3/4" accumulating roller chain with plastic or steel rollers	p. 215
Drive location	discharge end left/right	
Drive and speed	up to 30 m/min	p. 12
Stand and side rail		from p. 280
Standard total load	up to 1000 kg	higher on request
Standard distributed load	up to 150 kg/m	



Properties

The compact conveyor frame design and the ability to freely select the drive position over the entire length of the conveyor make it easier to integrate the conveyor into existing systems.

B20.12.010

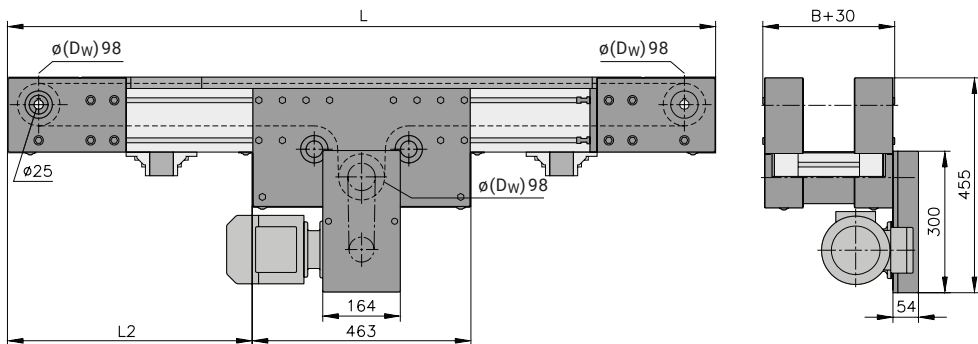

For information about wear strip variants, see page 213

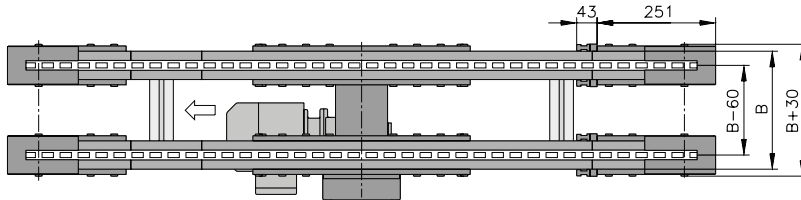

Technical data

Conveyor length L	individual from 1000–10000 mm (note the chain pitch)	
Conveyor width B	200 to 2000 mm	
Chains	3/4" accumulating roller chain with plastic or steel rollers	p. 215
Drive location	left/right underneath	
Drive and speed	up to 30 m/min	p. 12
Stand and side rail		from p. 280
Standard total load	up to 1000 kg	higher on request
Standard distributed load	up to 150 kg/m	

Properties

Since the motor is fitted directly onto the drive shaft, the space requirements and maintenance effort for this drive version are reduced to a minimum. The compact conveyor frame design and the ability to freely select the drive position over the entire length of the conveyor make it easier to integrate the conveyor into existing systems.

B20.12.011

5

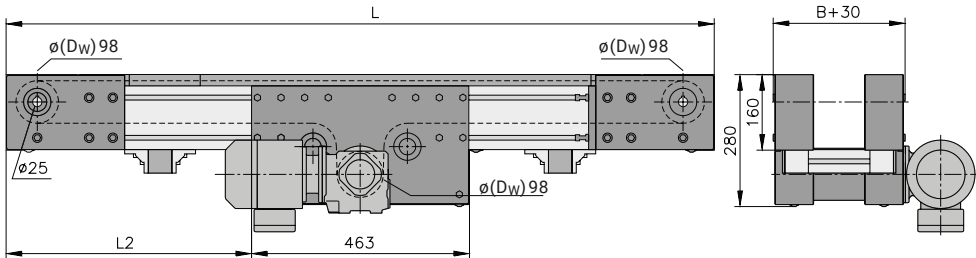

For information about wear strip variants, see page 213

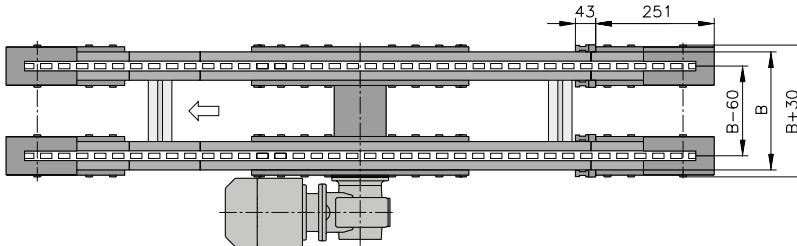

Technical data

Conveyor length L	individual from 1000–10000 mm (note the chain pitch)	
Conveyor width B	200 to 2000 mm	
Chains	3/4" accumulating roller chain with plastic or steel rollers	p. 215
Drive location	discharge end left/right	
Drive and speed	up to 30 m/min	p. 12
Stand and side rail		from p. 280
Standard total load	up to 1000 kg	higher on request
Standard distributed load	up to 150 kg/m	

SRF-P 2012 Wear Strips

Wear and guide strips from mk ensure low friction.
 The wear strips are made from PE-UHMW (PE-1000). Temperature range up to a maximum of 65° C.

Variant A

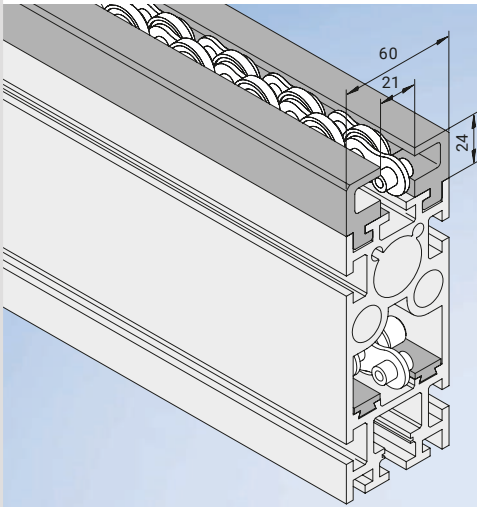

Top wear strip mk 1089
22.89.2000

Bottom wear strip mk 1022
22.22.2000

Variant B

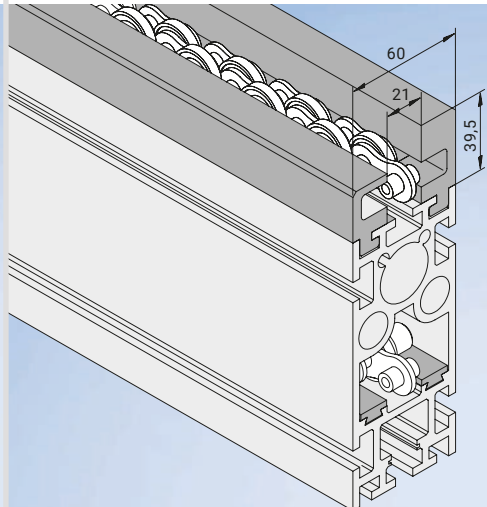

Top right wear strip mk 1050
22.50.2000

Top left wear strip mk 1089
22.89.2000

Bottom wear strip mk 1022
22.22.2000

Chains

... for KTF-P 2010

Single roller chain with straight nuts

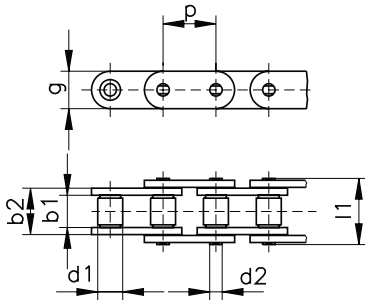

Double roller chain with straight nuts

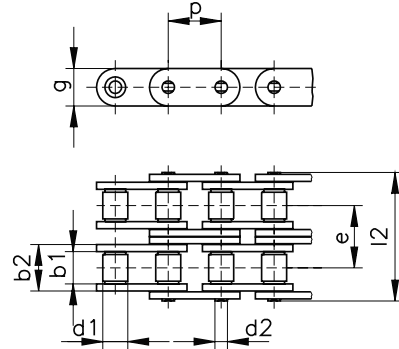

KTF-P 2010

Steel chain K11402
Locking link K114020001

KTF-P 2010

Steel chain K11416
Locking link K114160001

St = steel roll, VSG = locking link

Dimensions in mm

p	12.70 (1/2" x 5/16")	p	2.70 (1/2" x 5/16")
b1	7.75	b1	7.75
b2	11.30	b2	11.30
b3	•	b3	•
b4	•	b4	•
d1	8.51	d1	8.51
g	11.50	g	11.80
d2	4.45	d2	4.45
l1	17	l1	•
l2	•	l2	31
e	•	e	13.92
l	•	l	•
b5	•	b5	•
d	•	d	•

up to 60° C, special version up to 120° C

... for SRF-P 2010 and SRF-P 2012

Accumulating roller chain with accumulating rollers in series

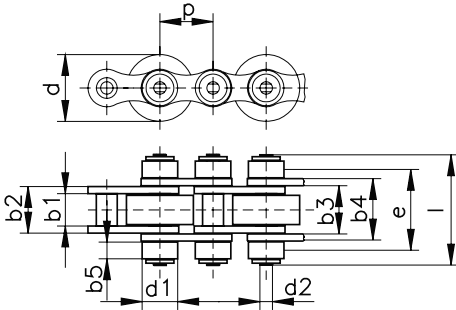

Accumulating roller chain with accumulating rollers offset

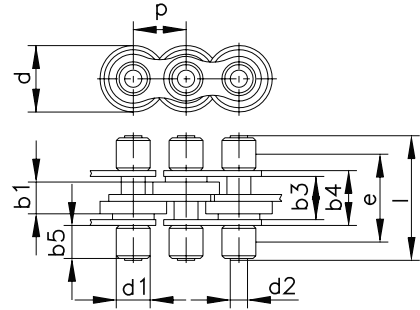

SRF-P 2010

Steel chain K11418
Chain, plastic roller, K11435
Steel chain, finger guard, K11425
Chain, plastic roller, finger guard, K11424
Locking link K114180001

SRF-P 2012

Steel chain K11415
Chain, plastic roller, K11407
Locking link K114060001

SRF-P 2010

Steel chain K11421
Chain, plastic roller, K11420
Locking link K114180001

SRF-P 2012

Steel chain K11423
Chain, plastic roller, K11422
Locking link K114060001

St = steel roller, Kst = plastic roller, FES = protective finger guard, VSG = locking link

Dimensions in mm

	12.70 (1/2")	19.05 (3/4")		12.70 (1/2")	19.05 (3/4")
p	12.70 (1/2")	19.05 (3/4")	p	12.70 (1/2")	19.05 (3/4")
b1	7.75	11.68	b1	9.20	11.70
b2	11.15	15.62	-	-	-
b3	11.40	15.80	b3	11.40	15.80
b4	14.70	20	b4	14.50	19.55
d1	8.50	12	d1	8.51	12.07
g	•	•	g	•	•
d2	4.45	5.72	d2	4.45	5.72
l1	•	•	l1	•	•
l2	•	•	l2	•	•
e	•	•	e	18.70	31.50
l	27	48	l	27	45
b5	4	11.50	b5	6.25	12.73
d	16	24	d	16	24

up to 60° C, special version up to 120° C

Accessories

Pallets

Pallets can be custom-configured to suit your specific application, whether they are delivered fully assembled or for self-assembly. The permitted total weight per pallet is determined by the total load capacity per metre of the system (100 kg/m). Please note that the clear width of the side rail must be 2 to 4 mm wider than the width of the pallet to guide the pallet in the optimal way.

Individual pallet components:

- Aluminium profile frame consisting of the profile mk 2260 and the corner pieces
- Plastic wear strips PE-1000 below the profile frame
- Support plates in varying thickness: 5, 6, 8, 10 and 12 mm
- Bumpers/rubber buffers
- Positioning sockets

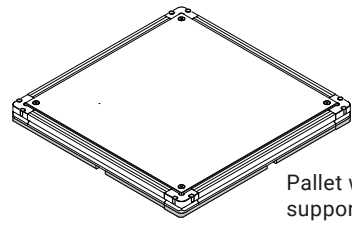
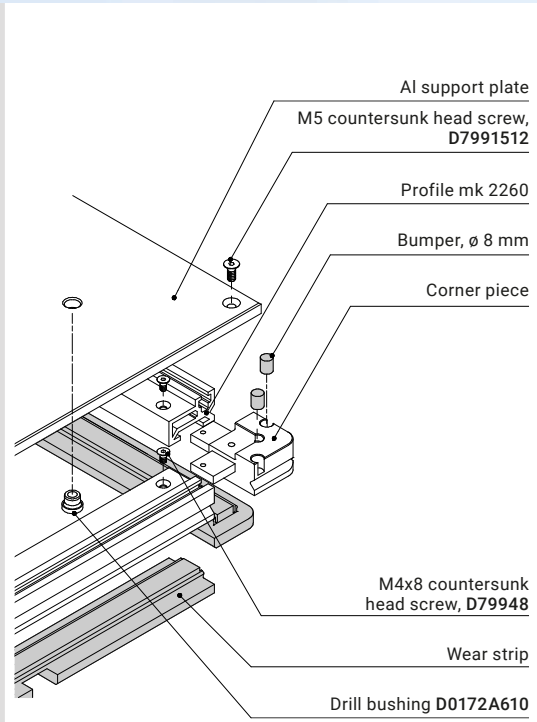

Pallet with support plate

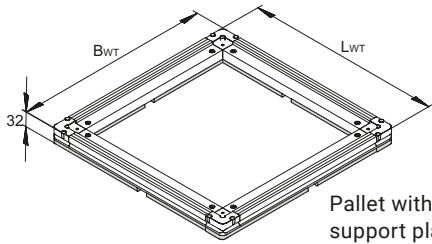

Pallet without support plate

W _{PT} mm	L _{PT} mm	Support plate mm	Weight _{PT} kg
400	400	8	5
400	600	8	8
600	600	10	14
600	800	10	16
800	800	12	24
800	1000	12	30

Maintenance Kit



Tensioning and Lubrication Station KTF/SRF-P 2010

The use of the optional automatic tensioning and lubrication station lets you avoid unnecessary maintenance tasks. There is no need to manually retension or manually oil the chain. Automatic tensioning does not change the length of the conveyor. In addition to the visual tensioning distance monitor, a tensioning distance sensor is also available, both with and without a lubricant insert.

5

Tensioning Device for SRF-P 2012

mk offers an optional automatic tensioning device that uses a traffic light marking to indicate when the chain needs to be shortened.

- Green: OK
- Yellow: Shortening not yet required
- Red: Chain must be shortened if the maximum elongation of 3% of the chain has not been reached

When the elongation reaches 3%, the chain and the sprocket wheels must be replaced.



Assembly Aid for Chain Replacement

To replace the accumulating roller chain, you must relieve the tension at the tail. The built-in assembly aid makes it easier to replace the chain by allowing you to remove one part of the wear strip separately. You must then advance the accumulating roller chain until the chain lock with the blue ring appears in the opened area. You can now replace the accumulating roller chain.



Return Stop

The return stop is used in combination with a stopper in transfer systems with low belt friction and prevents pallets from recoiling/rebounding while stopping. The return stop is activated through a spring.

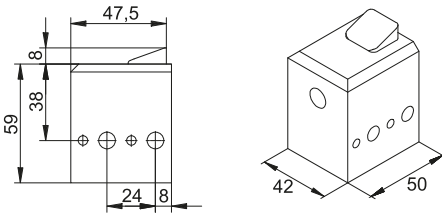

Return Stop
K503030101

Lowering stroke: 8 mm

Accessories

SU – Stopper Undamped

Stoppers are used to stop or separate the pallets. The stopper variants are selected based on the conveyor weight and conveyor speed. Customers can choose between a variety of stroke heights based on their requirements. Damped or undamped stoppers can be connected in the centre or on the sides.

They can be requested through inductive (I) or electric (E) sensors.

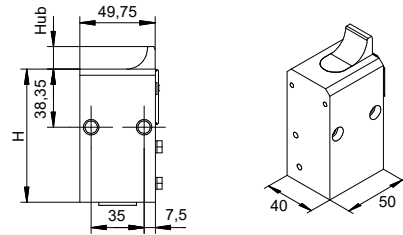

SU 400

SA=single-acting (locked in a depressurised state)

Ident. no.	Stroke	Re-quest	Stroke (mm)	V=6	V=9	V=12	V=18
				m/min	m/min	m/min	m/min
				[kg]	[kg]	[kg]	[kg]
K503011401	E		9	400	300	250	200
K503011405	I		9	400	300	250	200
K503011404	-		9	400	300	250	200
K503011406	E		15	400	300	250	200
K503011402	-		15	400	300	250	200

DA=double-acting (maintains the last position reached)

K503012401	E		9	400	300	250	200
K503012404	-		9	400	300	250	200
K503012405	I		9	400	300	250	200

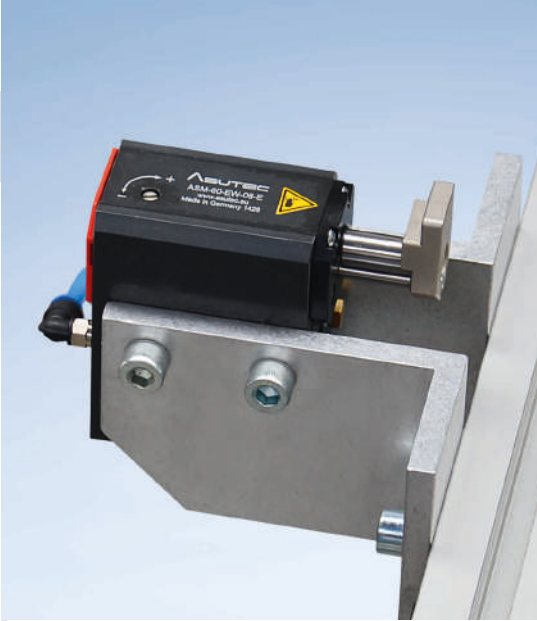

SD – Stopper Damped

Damped stopping allows you to gently slow down the first pallet. Damping prevents the workpiece from slipping in a certain location. Electrical or inductive sensors on the stoppers are optional. A minimum mass of 3 kg is required to ensure proper functioning. Damped or undamped stoppers can be connected in the centre or on the sides.

They can be requested through inductive (I) or electric (E) sensors.

5

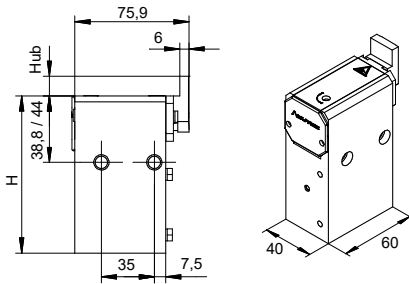

SD 60

SA=single-acting (locked in a depressurised state)

Ident. no.	Re-quest	Stroke (mm)	V=6	V=12	V=24	V=30
			m/min [kg]	m/min [kg]	m/min [kg]	m/min [kg]
K503021061	E	8	3-60	3-35	3-24	3-18
K503021063	-	8	3-60	3-35	3-24	3-18
K503021064	I	8	3-60	3-35	3-24	3-18

DA=double-acting (maintains the last position reached)

K503022061	E	8	3-60	3-35	3-24	3-18
K503022063	-	9	3-60	3-35	3-24	3-18
K503022064	I	10	3-60	3-35	3-24	3-18

The specifications apply for a friction coefficient of $\mu = 0.07$
Stoppers for heavier loads available upon request

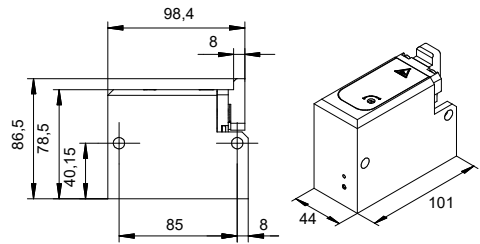

SD 100

SA=single-acting (locked in a depressurised state)

Ident. no.	Re-quest	Stroke (mm)	V=6	V=12	V=24	V=30
			m/min [kg]	m/min [kg]	m/min [kg]	m/min [kg]
K503021101	-	8	3-100	3-60	3-40	3-30
K503021102	I	8	3-100	3-60	3-40	3-30

DA=double-acting (maintains the last position reached)

K503022101	-	8	3-100	3-60	3-40	3-30
K503022102	I	8	3-100	3-60	3-40	3-30

The specifications apply for a friction coefficient of $\mu = 0.07$
Stoppers for heavier loads available upon request

Application Examples



KTF-P 2010 with head drive AC with drip pan and movable support frame

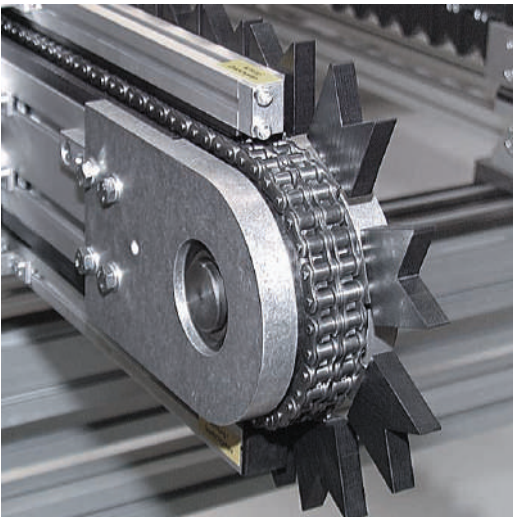

KTF-P 2010 with prism holders



KTF-P 2010 with adjustable side rail and clamp levers for workpieces that frequently change in width



Three-line conveyor KTF-P 2010



5

Combination of belt conveyor and chain conveyor with transverse rail for simulating a floor obstacle

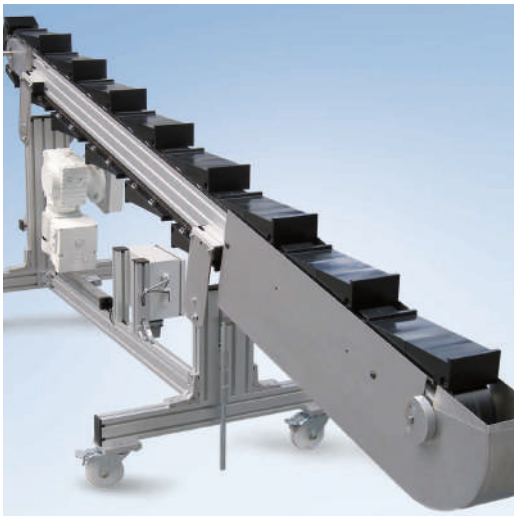

KTF-P 2040 with custom set-ups that allow the products to be mounted horizontally for incline transport

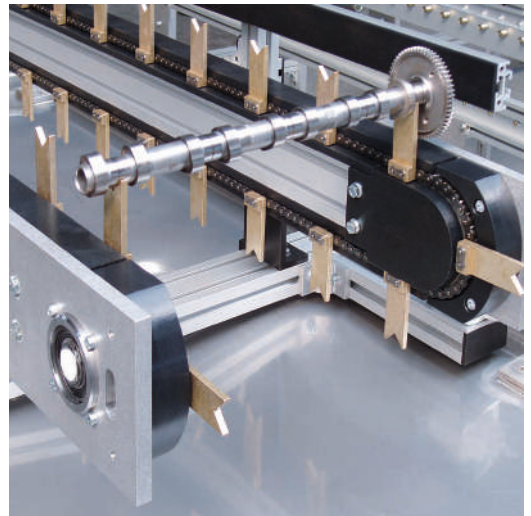

Indexing chain conveyor system TKU 2040 with prisms for carrying workpieces

Application Examples

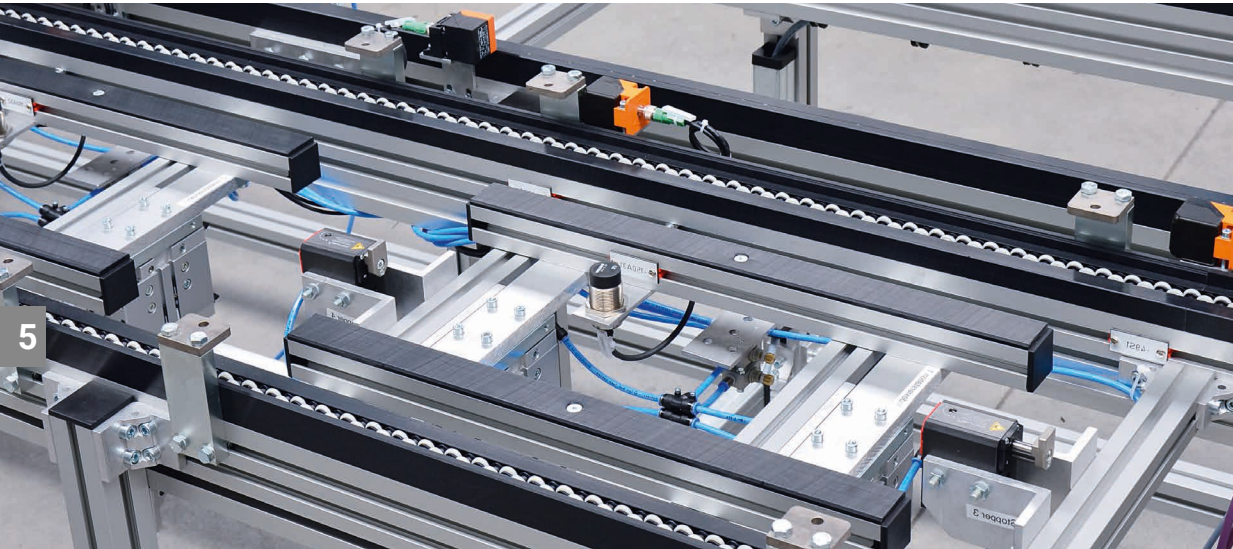

Robot unloading point with damped stoppers, pneumatic lifting feature with indexing from above and RFID read/write head

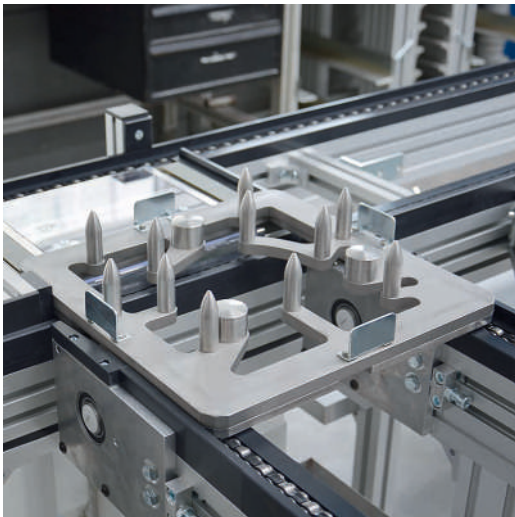

Customer-specific pallet with corrosion-resistant design for cleaning systems

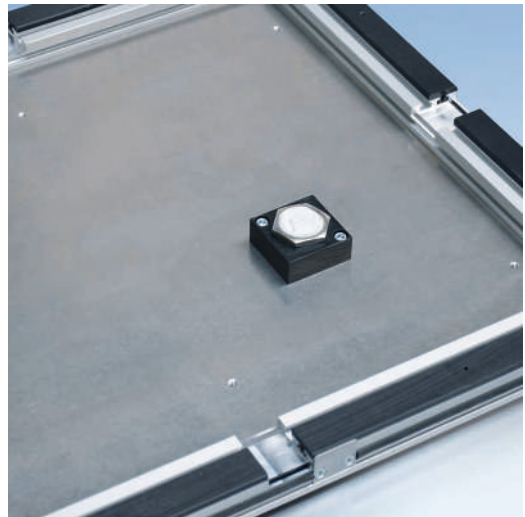

Pallet with optional RFID transponder

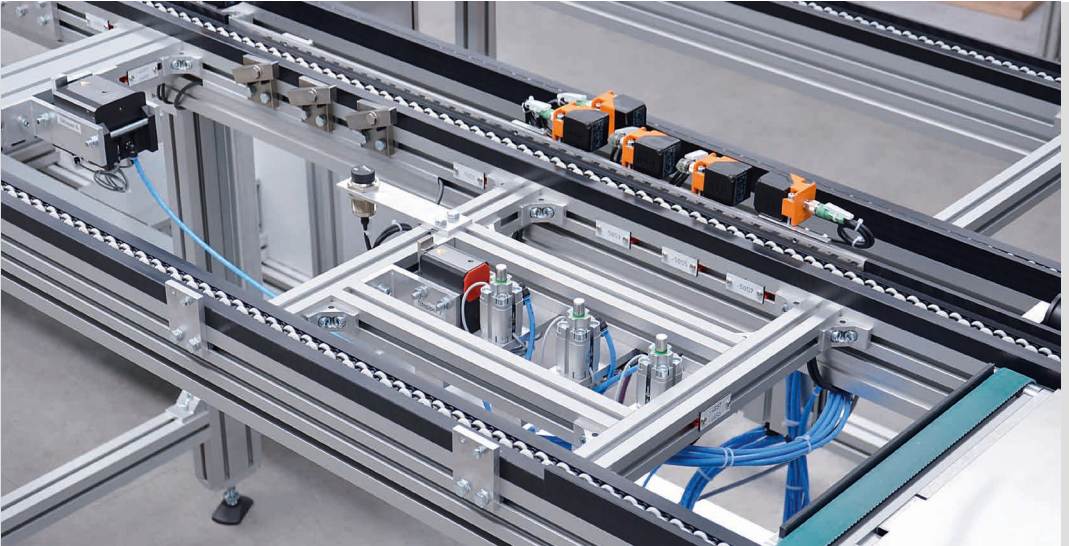

Station for four removal slots on a pallet with undamped stoppers and return stop. Accumulated pallets are separated upstream of the station during the process using damped stoppers on the buffer section.

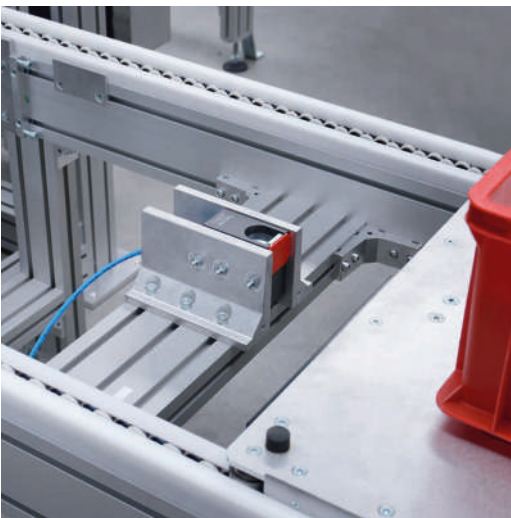

System SRF-P 2012 as a heavy-duty version with offset accumulating roller chain in POM wear strips and stopper SU 800

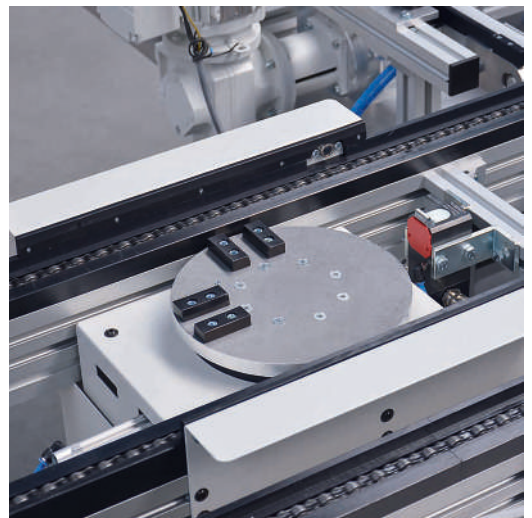

Intrinsically safe lift-and-turn station for pallets in interlinking production cells in the automotive industry

Application Examples



Interlinking production cells in the automotive industry
Manual pallet stocking, removal with customer-supplied handling system and robot. Lower return level with lift and shuttle.



Ready-for-use interlink with assembly automation



Lift and storage system for pallets with two chain conveyors running in opposite directions and pallet slots



Pallet circulation system for various transport levels with three-axis gantry

5



Foolproof part pickup for left-sided and right-sided products



Ready-for-use complete system with melting furnace and PLC

Chapter 6 Flat Top Chain Conveyors

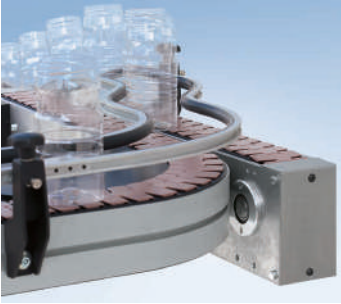

6	SBF-P 2254	228
	Configuration	230
	Modular Overview	231
	Flat Top Chains	234



SBF-EMMA	236
-----------------	-----



Application Examples	238
-----------------------------	-----

Flat Top Chain Conveyor SBF-P 2254



» Complex tracks running in feeding and interlinking applications. «

The SBF-P 2254 modular flat top chain conveyor is ideally suited for feeding and interlinking bottles, cans or small boxes in the food, beverage, glass, pharmaceutical and paint industries. Its modular design lets you create complex conveyor systems quickly and economically, and it minimises the work required to make changes to suit production conditions. The connecting elements specially designed for this system allow you to easily assemble the individual modules into a complex conveyor system. In addition to straight tracks, you can select from both sliding and rolling curves of 90° and 180° as well as transfer segments and inclines for bridging height differences.

Various flat top chains from different manufacturers can be delivered depending on your specific application. The slots on the sides of the mk 2254 conveyor frame profile allow you to connect side rails, stands, initiators and other accessories. The chain is guided entirely inside wear strips on both the upper and lower runs.

The flat top chain system is also available in stainless steel to meet the special requirements of the food industry.

Benefits of the SBF-P 2254

- Ideally suited for the food, beverage, glass, pharmaceutical and paint industries
- For feeding and interlinking bottles, cans and small boxes
- Modular design for fast and affordable creation of complex conveyor systems
- Track layout can be easily changed according to production conditions
- Side slots on the conveyor frame profile for attaching accessories such as side rails, stands, etc.

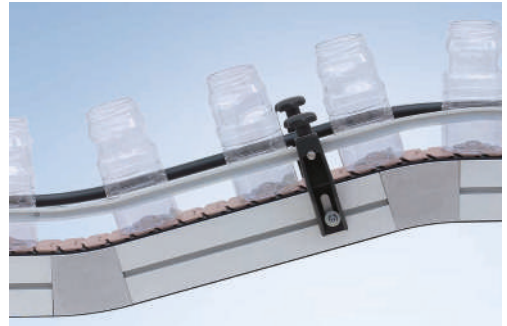
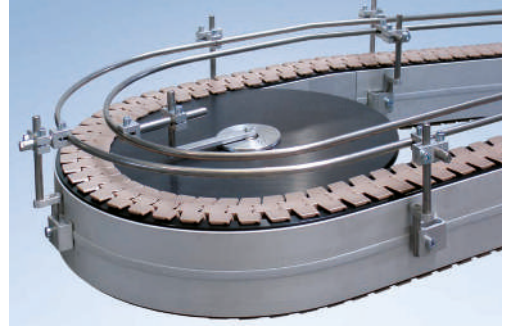

6

Cross Section

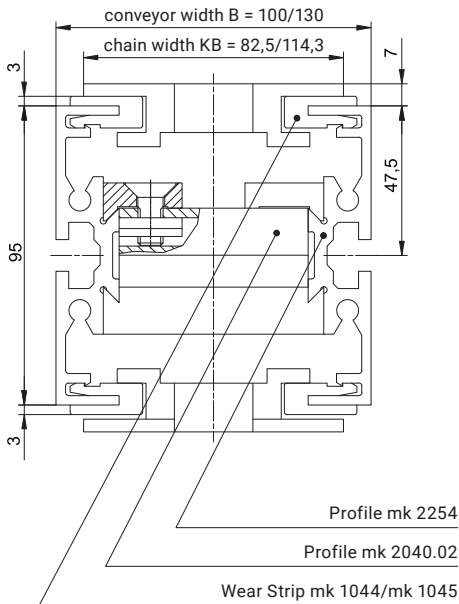

Flat Top Chain Conveyor SBF-P 2254

Configuration

A variety of different influencing factors must be taken into account when configuring flat top chain conveyors. The total chain length, number of curves, workpiece characteristics and, above all, the weight and speed, etc. have a decisive influence on the motor power required.

mk determines the motor power based on the individual application. During configuration, note that the direction (left/right) for the drive, transfer segments and curves must always be specified in the running direction (that is, the direction towards the drive).

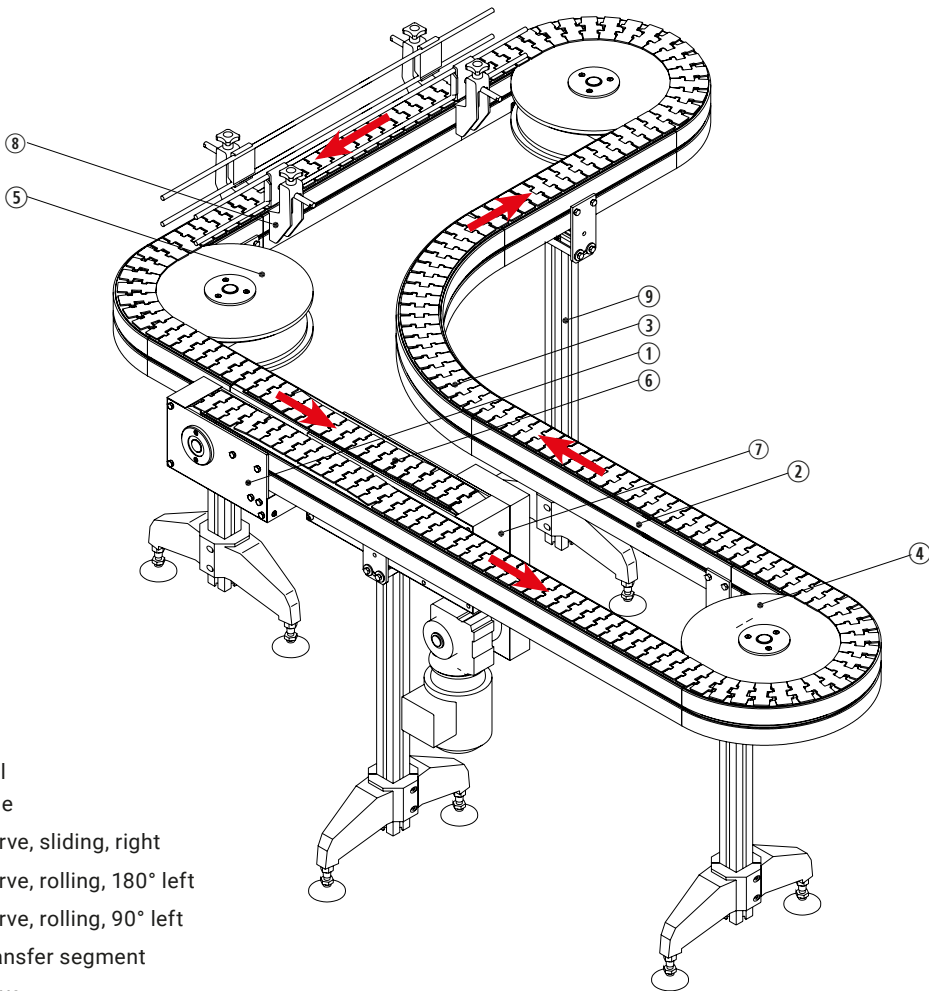

- ① Tail
- ② Line
- ③ Curve, sliding, right
- ④ Curve, rolling, 180° left
- ⑤ Curve, rolling, 90° left
- ⑥ Transfer segment
- ⑦ Drive
- ⑧ Side rail
- ⑨ Stand

SBF-P 2254 Modular Overview

The modules can only be ordered as spare parts and are not suitable for building a complete solution yourself.

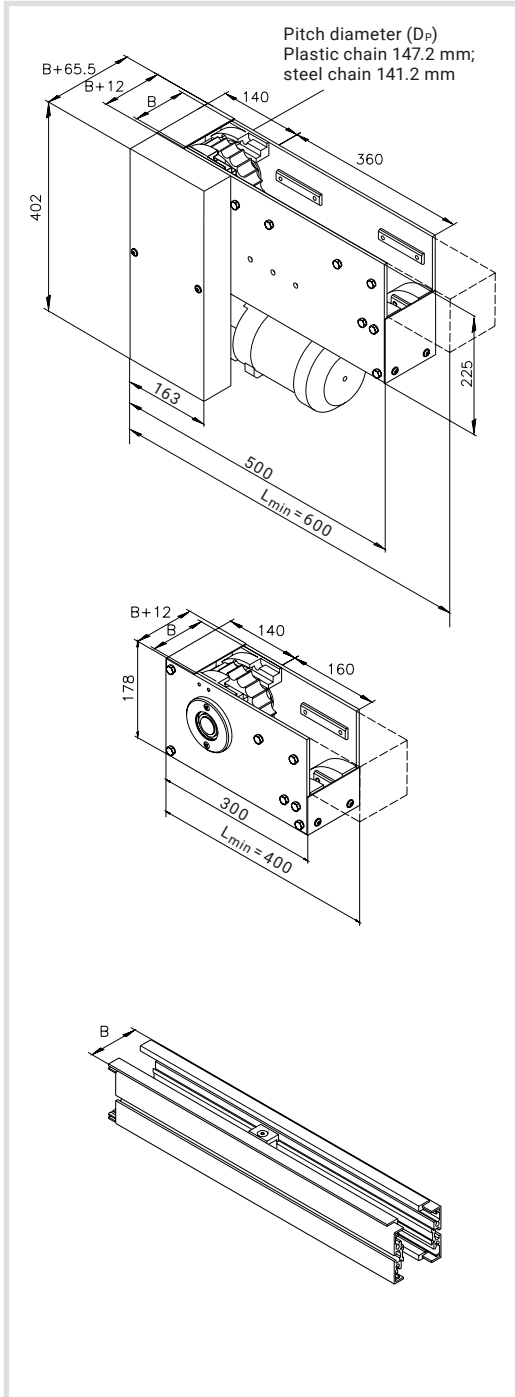

Drive AC

The motor can be positioned on the left (as shown) or on the right. The motor power ranges from 0.25 to 0.55 kW. The conveyor system can achieve speeds of approx. 8 to 40 m/min. Speeds below 8 m/min may cause the chain to run unevenly. Only straight line elements are permitted to be integrated in the range of $L_{min} = 600$ mm.

Width B	Chain width B1	Type	Item no.
100 mm	82.5 mm	Curved	B01.00.409*
130 mm	114.3 mm	Curved	B01.00.410*

*Without profiles, without chain

Tail

The tail consists of aluminium side plates with stainless steel covers and precisely guides the chain back into the upper run through high-quality curved sections. Only straight line elements are permitted to be integrated in the range of $L_{min} = 400$ mm.

Width B	Chain width B1	Type	Item no.
100 mm	82.5 mm	Curved	B80.00.409*
130 mm	114.3 mm	Curved	B80.00.410*

*Without profiles, without chain

Line

The conveyor frame is based on the profile mk 2254 and features a high level of torsion resistance. The chain is guided along the lower and upper run in PE 1000 wear strips.

Width B	Chain width B1	Item no.
100 mm	82.5 mm	B08.00.409*
130 mm	114.3 mm	B08.00.410*

*Assemblies with connecting elements, without a chain and without wear strips

SBF-P 2254 Modular Overview

The modules can only be ordered as spare parts and are not suitable for building a complete solution yourself.

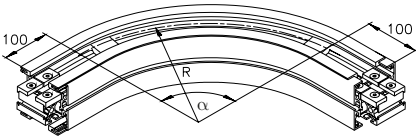

Curve, sliding

The chain is guided along the entire curve area in a high-quality PE 1000 wear strip. The dimensions of the wear strip ensure that the chain runs safely. This results in long conveyor service life. Sliding curves are primarily used in short conveyor systems with minimal loads and low speeds.

Width B	Chain width B1	R	Item no.
100 mm	82.5 mm	300 mm	B36.00.416*
100 mm	82.5 mm	500 mm	B36.00.414*
130 mm	114.3 mm	300 mm	B36.00.417*
130 mm	114.3 mm	610 mm	B36.00.415*

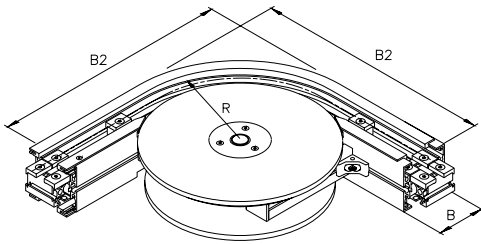

Curve, rolling, 90°

The rolling curved tail and rotating plastic washers on the inside of the curve significantly reduce the amount of friction that occurs in the conveyor system. This feature enables higher speeds, longer conveying paths and higher loads to be achieved.

Width B	Chain width B1	B2	R	Item no.
100 mm	82.5 mm	500 mm	200 mm	B36.00.428*
130 mm	114.3 mm	530 mm	200 mm	B36.00.429*

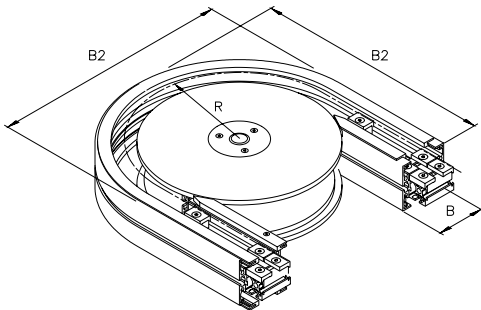

Curve, rolling, 180°

The rolling curved tail and rotating plastic washers on the inside of the curve significantly reduce the amount of friction that occurs in the conveyor system. This feature enables higher speeds, longer conveying paths and higher loads to be achieved.

Width B	Chain width B1	B2	R	Item no.
100 mm	82.5 mm	500 mm	200 mm	B36.00.430*
130 mm	114.3 mm	530 mm	200 mm	B36.00.431*

*Assemblies with connecting elements, without a chain and without wear strips

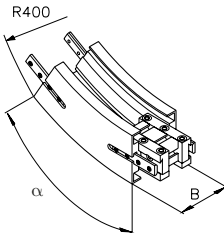

Vertical Incline

The incline can be used to overcome height differences. Depending on the product, we recommend using cleated chains to prevent the product from slipping back. Like in the curve segments, wear strips ensure that the chain runs safely and without much friction.

Width B	Chain width B1	L	Item no.
100 mm	82.5 mm	15°	B36.00.434*
100 mm	82.5 mm	30°	B36.00.435*
100 mm	82.5 mm	45°	B36.00.436*
130 mm	114.3 mm	15°	B36.00.438*
130 mm	114.3 mm	30°	B36.00.439*
130 mm	114.3 mm	45°	B36.00.440*

*Assemblies with connecting elements, without a chain

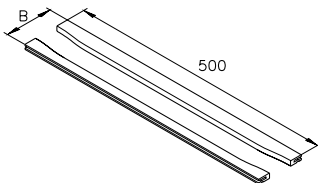

Transfer Segment

The tail consists of aluminium side plates with stainless steel covers and precisely guides the chain back into the upper run through high-quality curved sections. Only straight line elements are permitted to be integrated in the range of $L_{\min} = 400$ mm.

Width B	Chain width B1	L	Item no.
100 mm	82.5 mm	500 mm	B37.00.002
130 mm	114.3 mm	500 mm	B37.00.003

Wear Strips Section

mk wear strips made from polyethylene (PE 1000) reduce friction and ensure that the flat top chain runs securely. This results in a long conveyor service life.



Width B	Chain width B1	L	Item no.
100 mm	82.5 mm	2000 mm	22.44.2000
130 mm	114.3 mm	2000 mm	22.45.2000

Flat Top Chains

The flat top chains presented in these tables are our proven standard. All the chains shown are FDA-compliant. Plastic chains are not suitable for sharp-edge products or for cleaning with phosphoric/nitric acid. Rather than selecting the right chain based on the permitted driving force, with mk you can use our chain calculation program, which takes into account conveyor length, chain speed, back pressure, lubrication, product type and weight to find the perfect chain for your specific application. Additional chains are available on request.

6

Plastic Chains

Designation	Item no.	Conveyor width [mm]	Chain width [mm]	R min [mm]	Perm. operating force [N]	Material	Cam hardness
	LF 880 TAB-BO-K325	K114510031	100	82.5	200	1680	POM, brown
	LF 880 TAB-K325	K114510030	100	82.5	500	2100	POM, brown
	LF 880 TAB-BO-K450	K114510090	130	114.3	200	1680	POM, brown
	LF 880 TAB-K450	K114510085	130	114.3	500	2100	POM, brown
	WLF 880 TAB-BO-K325	K114510048	100	82.5	200	1680	POM, white
	WLF 880 TAB-BO-K450	K114510091	130	114.3	200	1680	POM, white
	With cam (not suitable for accumulated operation or lateral movement)						
	HFP 880 TAB-BOT-K325	K114510044	100	82.5	200	1680	POM, brown
HFP 879 TAB-BO-K450	K114510094	130	114.3	200	2100	POM, brown	60 Shore A

Steel chains

Designation	Item no.	Conveyor width [mm]	Chain width [mm]	R min [mm]	Perm. operating force [N]	Material	
	S 881 TAB-K325	K114510047	100	82.5	500	8350	Carbon steel, hardened
	S 881 TAB-K450	K114510063	130	114.3	610	8350	Carbon steel, hardened
	SSR 8811 TAB-BO-K325	K114510022	100	82.5	200	4500	Stainless steel, non-corrosive
	SSC 8811 TAB-K450	K114510062	130	114.3	500	6000	Stainless steel, non-corrosive

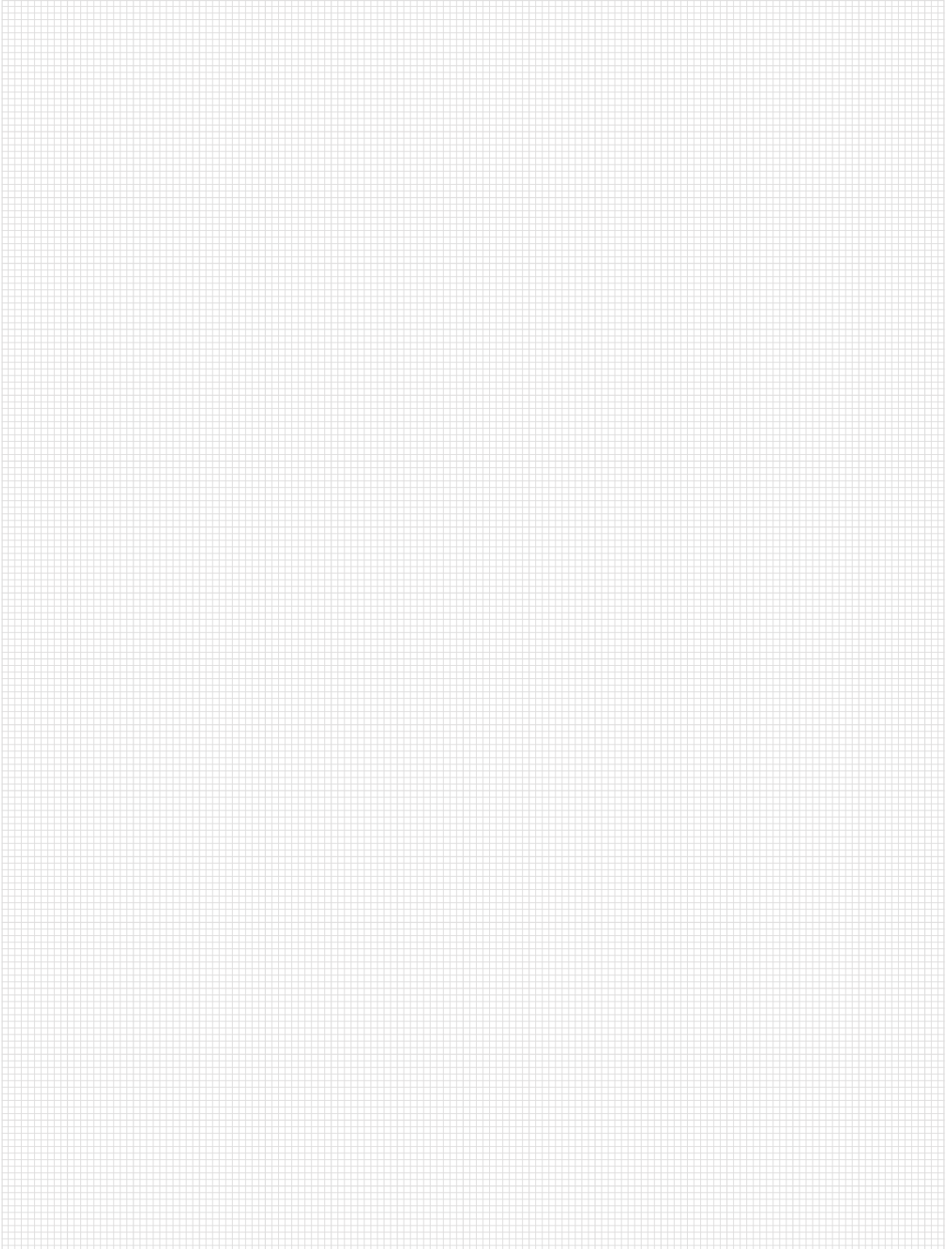

Flat Top Chain Conveyor SBF-EMMA



» Modular conveyor system available as a turnkey solution or for you to build. «

The fully modular and standardised flat top chain conveyors from our subsidiary EMMA are an integral part of the mk portfolio. They will replace the previous flat top chain conveyor SBF-P 2254 in the medium term.

The range of options is much greater compared to the SBF-P 2254. The conveyor widths for the system begin at 45 mm for products starting from 10 mm wide and end at 295 mm for products up to 400 mm wide. Combined with the large selection of chains and cams, the system is extremely flexible. As a result, it lets you find practically any solution for every application. It can also be used for gentle transport and precise positioning with pallets.

EMMA flat top chain conveyors have seen huge success in a wide variety of industry applications in recent years and transport a vast array of products to their destination with maximum reliability.

You can find all our information and news about EMMA flat top chain conveyors on our website or at www.e-m-m-a.eu. You can also find the comprehensive EMMA component catalogue there.

Benefits of SBF-EMMA

- Modular design with standardised components
- Easy to configure and cost-effective to create
- Can quickly be adapted to changed production conditions
- Very simple to extend or redeploy
- Energy and space saving
- Slots on the conveyor frame profile for attaching accessories, side rails, etc.

Technical data SBF-EMMA

- Widths: 45 mm, 65 mm, 85 mm, 105 mm, 175 mm and 295 mm
- Lengths: up to 40000 mm
- Total load: up to 200 kg
- Speed: up to 50 m/min

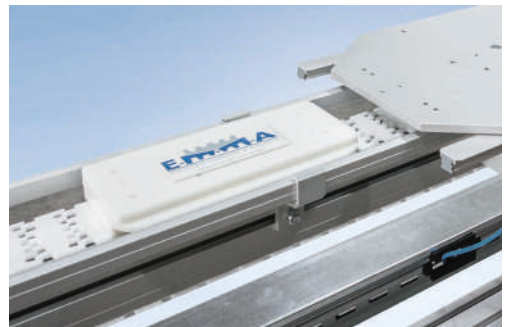
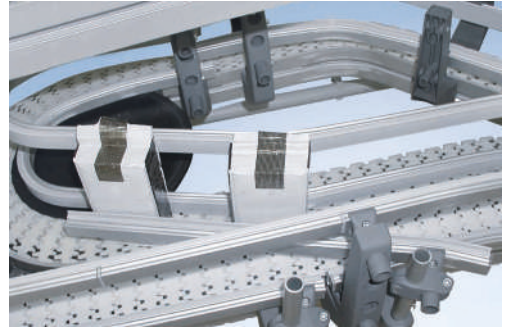

Application Examples



SBF-P 2254 for transporting boxes before and after filling

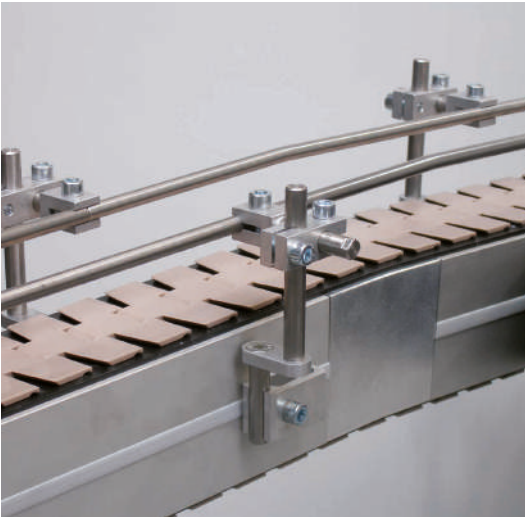

Short vertical incline with side rail

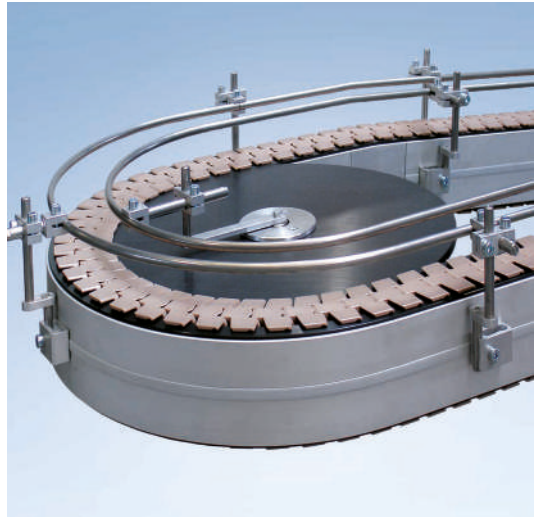

180° curve element



6

SBF-P 2254 as an interlink with a removal and loading station for pallet holders

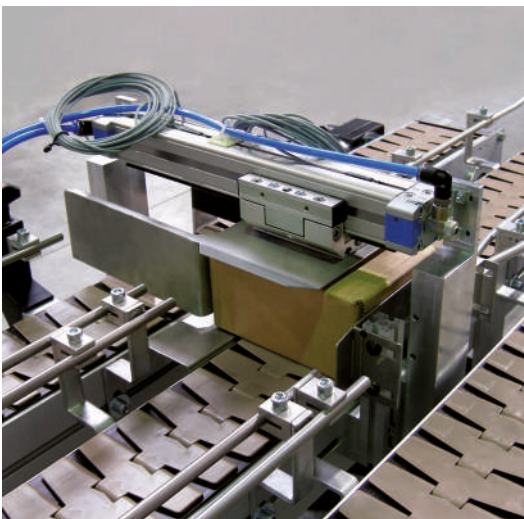

SBF-P 2254 with transfer pusher for the packaging industry, for instance



Transfer segment with side rail

Application Examples

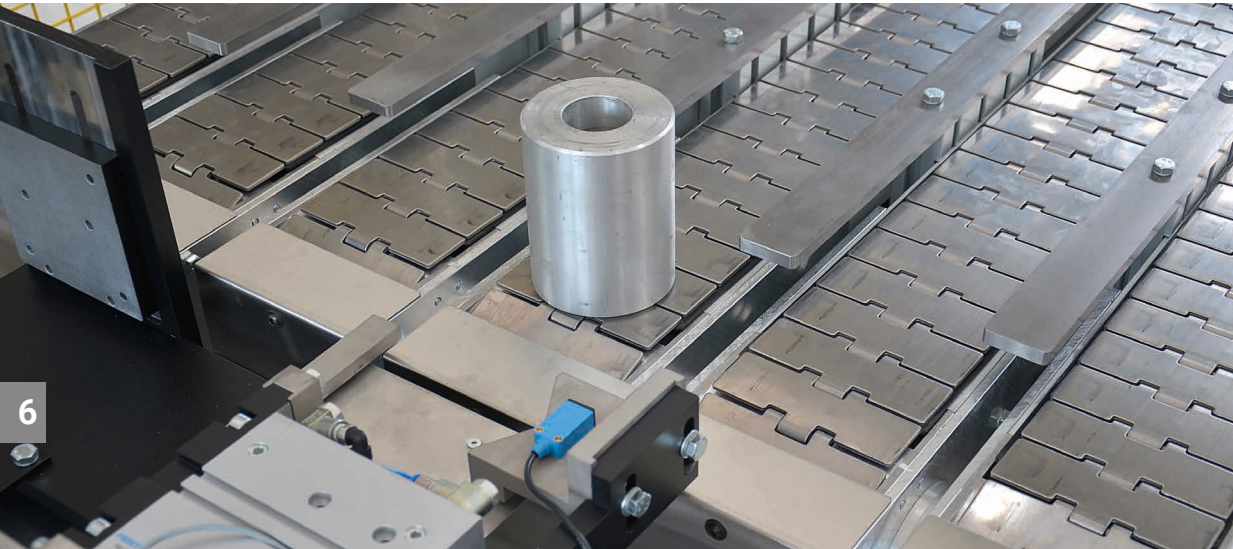

6

Multiple flat top chain conveyors on a shared conveyor frame for transporting various classified goods



Double-line flat top chain conveyor with one motor

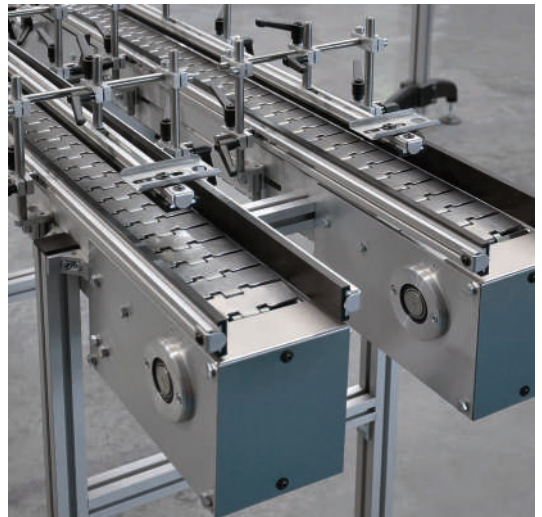

Dual-line flat top chain conveyor with side rail SF 02 with adjustable guide height and width

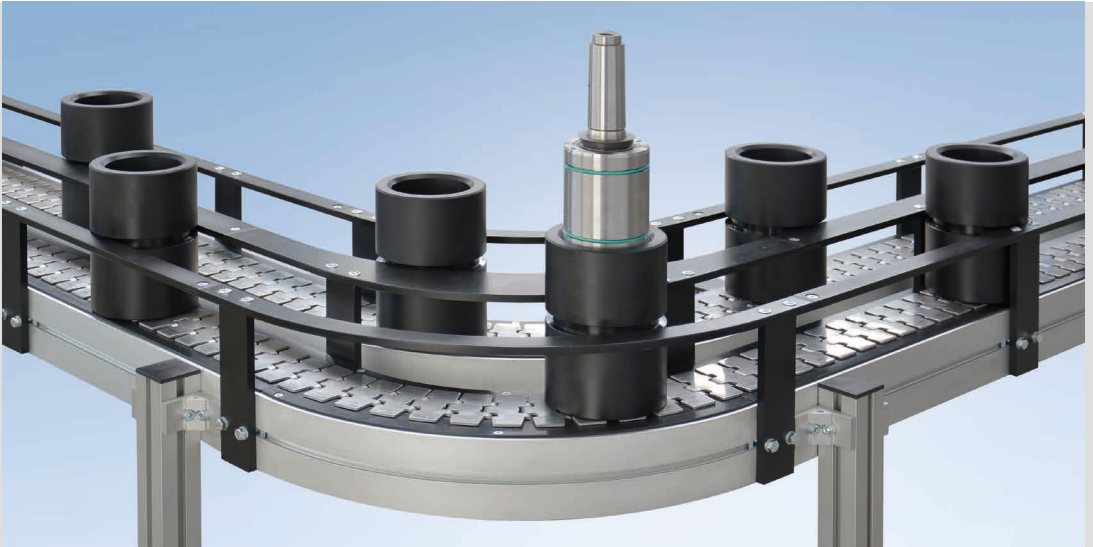

6

SBF-P 2254 with 90° sliding curve and steel flat top chain as an interlinking device for shaft parts

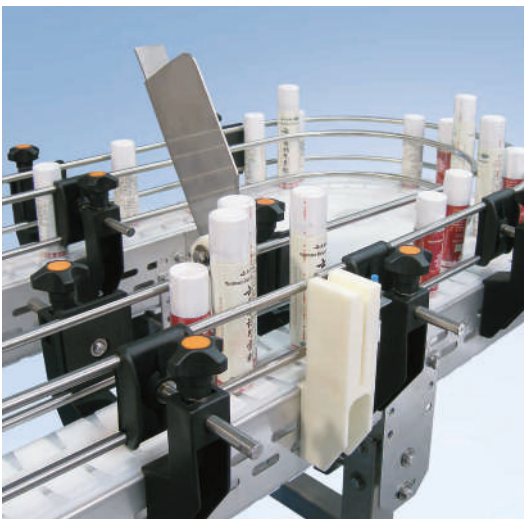

Interlink with INOX flat top chain conveyor with rolling 180° curve



INOX flat top chain conveyor curve, sliding 90°

Application Examples



Pallet system based on SBF EMMA A08 with separator



SBF EMMA with pressure rollers for vertical transport



SBF EMMA with rolling curves and side rails

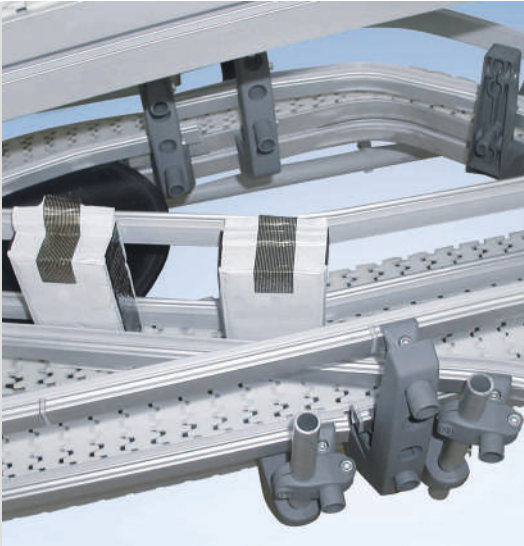

SBF EMMA with adjustable side rails



SBF EMMA stainless steel conveyor with automatically adjustable side rail ASTRA

6



SBF EMMA as a parallel multi-line system

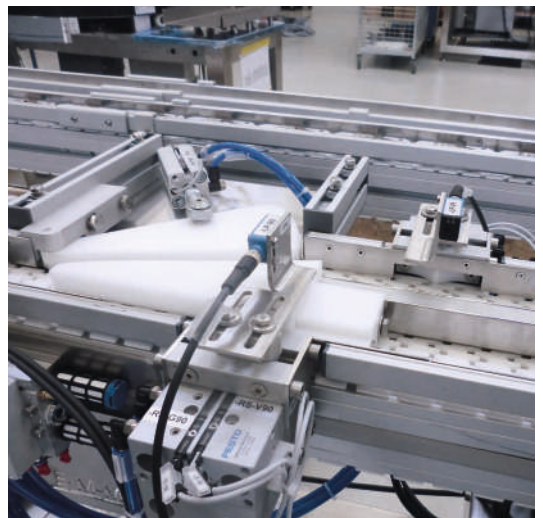

SBF EMMA with custom separation function

Chapter 7 Roller Conveyors



Selecting a Roller Conveyor

246



Gravity Roller Conveyor RBS-P 2065/2066

248

Line

250

Curve

251



Gravity Roller Conveyor RBS-P 2255

252

Line

254

Curve

255



Tangential Chain Roller Conveyor RBT-P 2255

256

Line

258

Curve

259



Drive Roller Conveyor RBM-P 2255

260

Line

262

Curve

263



Rollers

264



Application Examples 266

Selecting a Roller Conveyor

Dimensions – Technical Data

Conveyor system	Conveyor widths [mm]	Conveyor lengths [mm]	Total load* as standard, up to [kg]	Speed up to [m/min]	ø of tails [mm]	Reverse operation	Accumulated operation	Cycling operation
Gravity roller conveyors								
RBS-P 2065/2066	150–1050	200–5000**	400	30	approx. 90	•	•	•
RBS-P 2255	150–1050	500–10000**	400	30	approx. 90	•	•	•
Roller conveyor with tangential chain drive								
RBT-P 2255	320–720	500–10000	400	30	approx. 90	•	•	•
Roller conveyor with drive roller								
RBM-P 2255	480–680	500–10000	400	70	approx. 90	•	•	•

*Maximum load that is transported by the system in question with a standard configuration and for a standard application.

**Length refers to one roller conveyor segment (single piece). With the joints, there is no limit on the lengths that are possible.

7

Selecting the Roller Type Based on the Width and Load per Roller

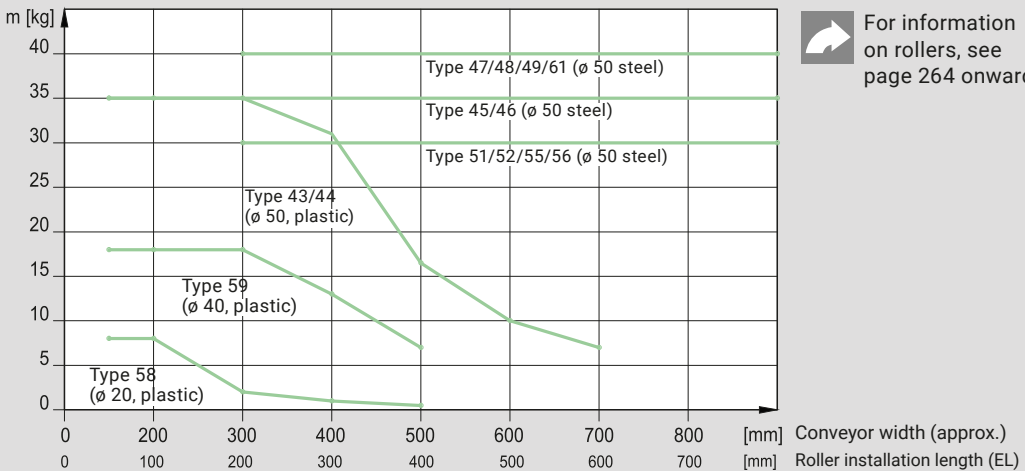

Roller Spacing Based on the Product Length (LP)

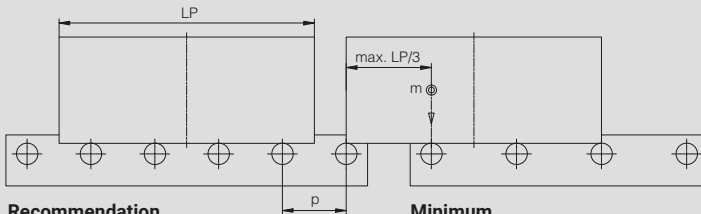

Recommendation

- 4 rollers under the product
- ± distribution $p = 150$ mm with $LP = 600$ mm
- Runs very smoothly
- Can work with uneven loads

Minimum

- 3 rollers under the product
- ± distribution $p = 200$ mm with $LP = 600$ mm
- Limit is $m = 100$ kg with 33 kg/roll
- Suitable for $m = 50$ kg with central centre of gravity for the load

Application Options

Gravity roller conveyors (RBS) are often used for semi-automatic interlinking at picking stations or kanban shelves. You can select rollers between \varnothing 20 and 50 mm depending on your total load and the required spacing. The RBS-P 2065 is the correct choice if you do not require the profile frame to act as a side rail – as is the case with the RBS-P 2066 – or if the product is wider than the roller conveyor. A slope of 1 to 2° is usually sufficient for conveying products with gravitational force. Please note that high speeds can be reached with long lines and/or steeper slopes. This kinetic energy will require dampened deceleration.

Our **roller conveyor tangential chain drive (RBT)** is used wherever long conveying paths with a motorised drive mechanism are required. The conveyor is driven by a ½" chain, which runs within an enclosed, low-wear wear strip to tangentially drive the conveyor rollers from below via a sprocket wheel. It can be used to drive conveying paths up to 10 m long. The chain tail is equipped with idler pulleys supported by ball bearings for minimal friction losses.

Roller conveyors with a drive roller (RBM) allow you to drive up to nine additional rollers using the round belt. They are notable for their few obstructing edges and easy-to-clean design, making them well suited for clean environments and increased sanitary requirements. They are also available in an IP66 version on request, or with an electronic holding brake for upward and downward gradients.

Rollers with a friction drive are available for dynamic buffering tracks. These rollers reduce back pressure, and the roller remains stationary under the product without any relative motion (bi-directional friction preferred if the load distribution is uncertain). Adjustable friction rollers are particularly useful for lightweight products. Gripping of the product can be increased up to the adhesion limit between the product and the roller. This is used, for example, for high acceleration, for inclines or for positioning the product.

7

Necessary Effective Width NB of a Curve Based on the Product Dimensions

Additional requirement (X) for conveyor width (B) for straight sections when connecting to curves:

RBS-/RBM-P 2255: X = 98 mm
 RBT-P 2255: X = 125 mm

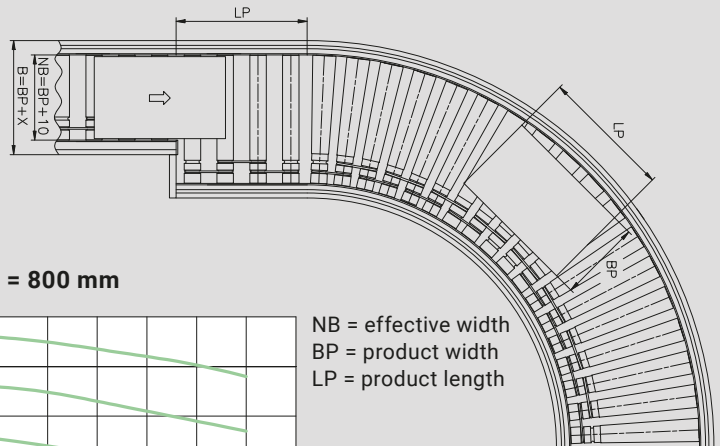

Examples for Curve Radius Ri = 800 mm

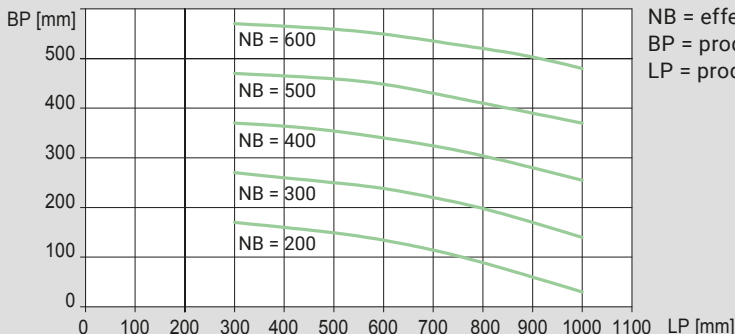

NB = effective width
 BP = product width
 LP = product length

Gravity Roller Conveyor RBS-P 2065/2066



» Straight and curved sections for transporting products of low to moderate weight. «

The roller conveyor system with gravity drive (RBS) is typically used in industrial automation for semi-automatic interlinking at picking stations or kanban shelves. The difference between the RBS-P 2065 and 2066 roller conveyors is that the RBS-P 2066's conveyor frame profile serves as the side rail, while in the RBS-P 2065 the rollers protrude beyond the side profiles, making the system suitable for extra-wide products and lateral discharging.

An extensive selection of different roller types makes the system extremely flexible and suitable for a wide range of applications. The conveyors are available in both straight and curved configurations. The roller diameters of 20, 40 or 50 mm ensure that both large and small workpieces can be transported reliably and without interruption. The longitudinal slots in the profile beams can be used to attach side rails, stands, initiators and other accessories.

Products can be transported along a downward gradient either by hand or using gravitational force. A slope of 1 to 2° is usually sufficient for conveying products with gravitational force. Please note that high speeds can be reached with long lines and/or steeper slopes. This kinetic energy will require dampened deceleration.

Benefits of the RBS-P 2065/2066

- For transporting products of low to moderate weight
- Semi-automatic interlinking at picking stations or even kanban shelves
- Conveyor frame profile of the RBS-P 2066 functions as the side rail
- Conveyor frame profile of the RBS-P 2065 allows for extra-wide product and lateral discharging
- Side slots on the conveyor frame profile for attaching accessories such as side rails, stands, etc.

Cross Section

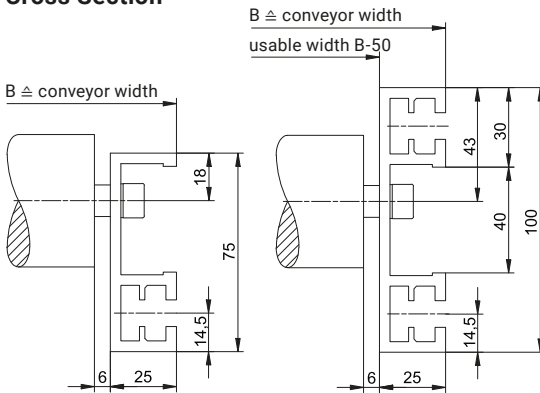

RBS-P 2065/2066 Straight Section

Properties

A feature of the gravity roller conveyors RBS-P 2065 and 2066 is that the rollers protrude over the profile edge with conveyor frame profile 2065 (making them suitable for extra-wide product). In addition, the conveyor frame profile on the RBS-P 2066 serves as a side rail.

∅ 20: B61.00.001 / ∅ 40: B61.00.002/∅ 50: B61.00.003

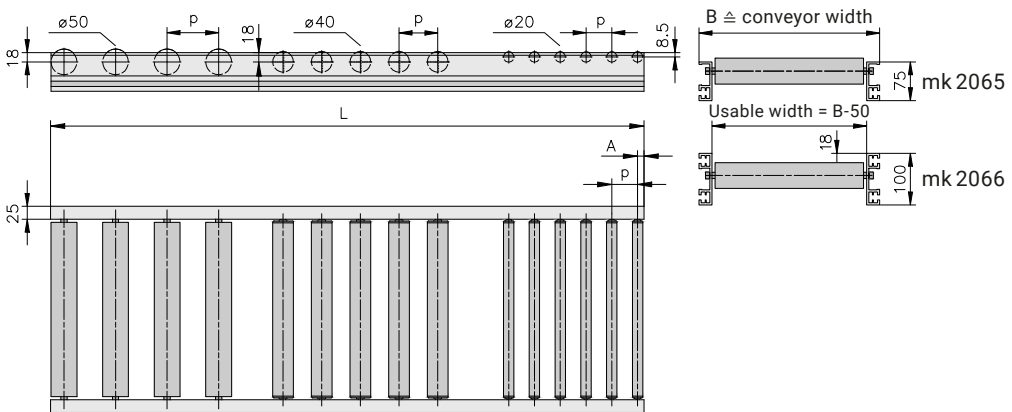

Technical data

Conveyor width B	∅ 20, plastic ∅ 40, plastic ∅ 50, plastic ∅ 50, galv. steel	150, 200, 250, 300 and 350 mm 150, 200, 250, 300 and 350 mm 250, 350, 450, 550 and 650 mm 250–1050 mm in 100 mm increments	Ident. no.: B61.00.001 Ident. no.: B61.00.002 Ident. no.: B61.00.003 Ident. no.: B61.00.003
Conveyor length L		200–5000 mm	
Spacing p	∅ 20 ∅ 40 ∅ 50	25, 50 and 75 mm 50, 75, 100 and 125 mm 75, 100, 125, 150, 175, 200, 225 and 250 mm	A = 12.5 mm A = 25 mm A = 25 mm
Conveyor frame profile		mk 2065 or mk 2066	
Roller types		Type 43–46, 58 and 59	from p. 264
Stand			from p. 280
Load capacity, usual		depending on the conveyor width and conveyor roller, up to 100 kg/m and a total load capacity of 400 kg	higher on request

RBS-P 2066 Curve

Properties

The gravity roller conveyor 2066 has an impressively simple design. The conical conveyor rollers that it uses prevent the transported product from twisting on the conveyor.

B61.00.004

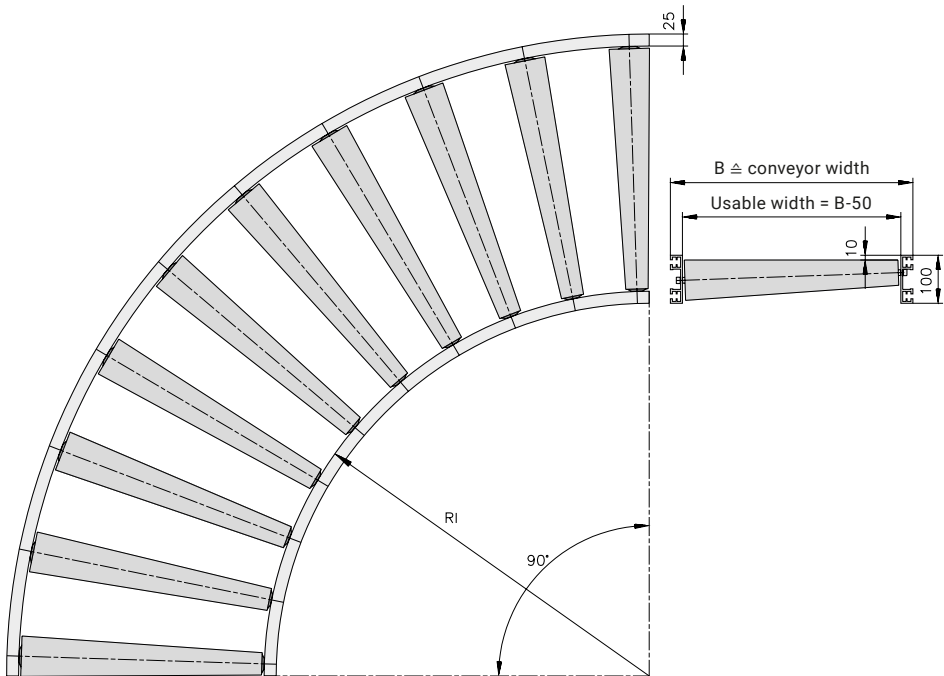

Technical data

Conveyor width B	310–860 mm in 50 mm increments							
Inner radius RI	800 (with B = 360, 460, 560, 660, 760, 860) 850 (with B = 310, 410, 510, 610, 710, 810)							
Conveying angle	90°							others on request
Conveyed product length	150	200	250	300	350	450	550	
recommended number of rollers	21	17	15	13	11	10	9	
Conveyor frame profile	mk 2066							
Roller types	Type 47 and 48							from p. 264
Stand								from p. 280
Load capacity, standard	depending on the conveyor width and conveyor roller, up to 100 kg/90°							higher on request

Gravity Roller Conveyor RBS-P 2255



» Straight and curved sections for transporting products of moderate weight. «

The roller conveyor system with gravity drive (RBS) is typically used in industrial applications for semi-automatic interlinking at picking stations, on buffering tracks, in interim storage or in assembly lines. Products can be transported along a downward gradient either by hand or using gravitational force. The sturdier mk 2255 profile makes the RBS-P 2255 gravity roller conveyor suitable for heavier loads than the RBS-P 2065/66 system.

The gravity roller conveyor is available in both straight and curved configurations and can be combined with driven roller conveyors (RBT and RBM). All roller conveyors are built from the mk 2255 roller conveyor profile, which includes longitudinal slots in the profile beams for attaching side rails, stands, initiators and other accessories.

Products can be transported along a downward gradient either by hand or using gravitational force. A slope of 1 to 2° is usually sufficient for conveying products with gravitational force. Please note that high speeds can be reached with long lines and/or steeper slopes. This kinetic energy will require dampened deceleration.

Benefits of RBS-P 2255

- For transporting products of moderate weight
- Semi-automatic interlinking at picking stations, on buffering tracks, in interim storage or in assembly lines
- mk 2255 conveyor frame profile allows for combination with driven roller conveyors (RBT, RBM)
- Side slots on the conveyor frame profile for attaching accessories such as side rails, stands, etc.

Cross Section

$B \triangleq$ conveyor width
 usable width B-88

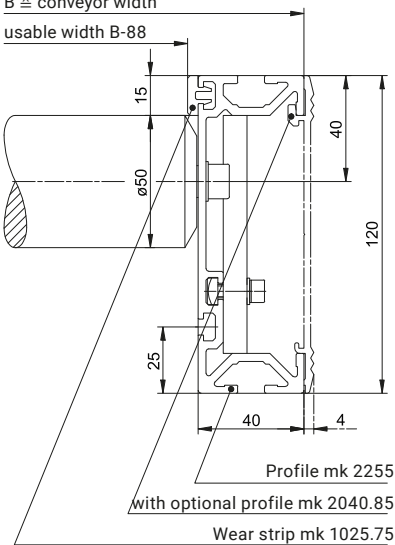

RBS-P 2255 Straight Section

Properties

The gravity roller conveyor is based on the mk 2255 profile. The anodised conveyor frame profiles are designed for spacings of 75, 100 and 125 mm, and a roller diameter of 50 mm.

B61.02.001

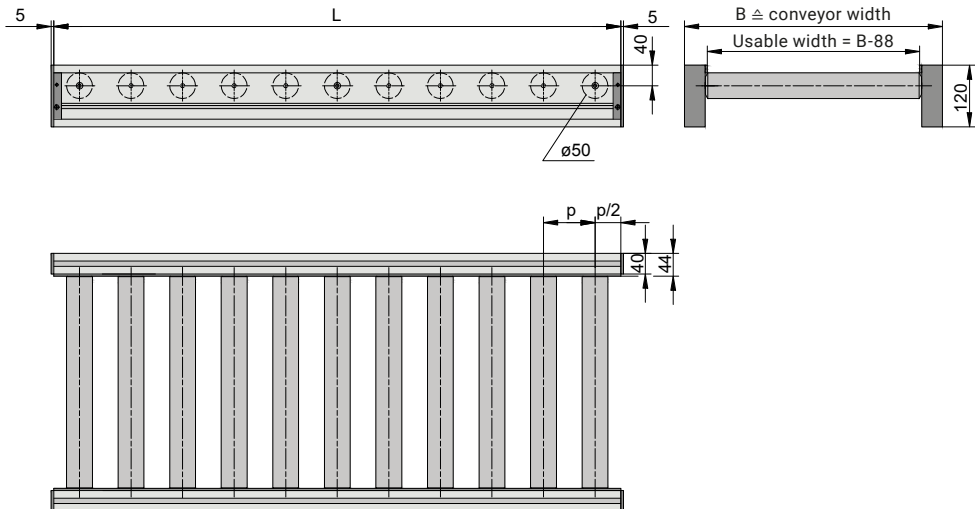

Technical data

Roller diameter	50 mm, plastic/galv. steel	
Conveyor width B	290, 390, 490, 590 and 690 mm	
Conveyor length L	500–10000 mm	
Spacing p	75, 100 and 125 mm	
Conveyor frame profile	mk 2255	
Roller types	plastic 43 + 44 or steel 45 + 46	from p. 264
Stand	only with conveyor stand option variant D	from p. 280
Load capacity, standard	depending on the conveyor width and conveyor roller, up to 100 kg/m and a total load capacity of 400 kg	higher on request

RBS-P 2255 Curved Section

Properties

The gravity roller conveyor is based on the mk 2255 profile. The anodised conveyor frame profiles are designed for a 5° spacing and a roller diameter of 50 mm.

B61.02.002

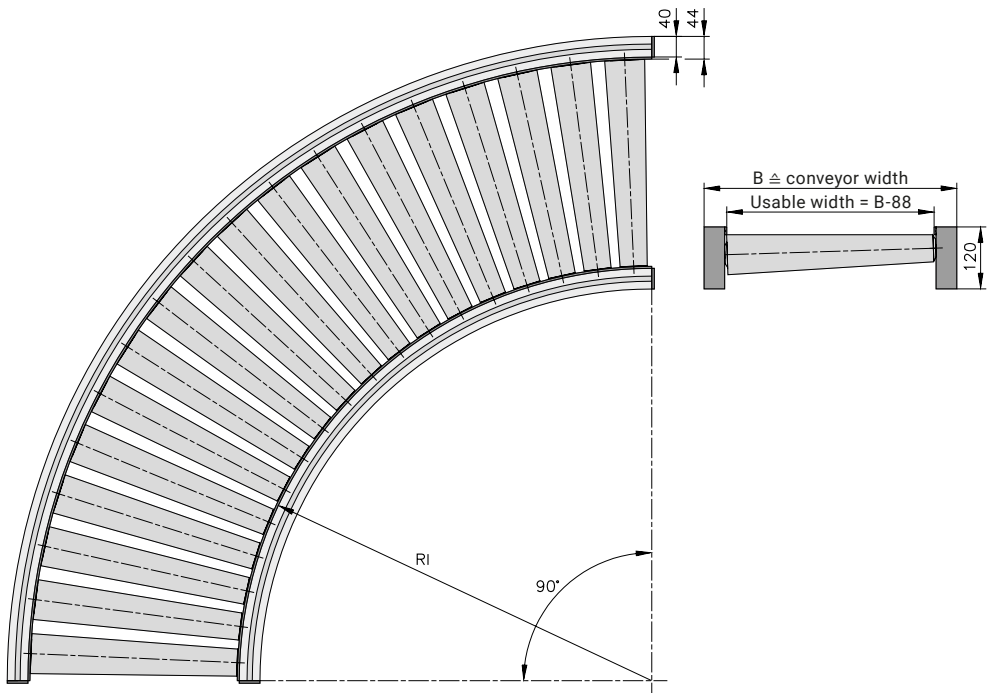

Technical data

Roller diameter	50 mm, conical, made from plastic	
Conveyor width B	390, 490, 590 and 690 mm	
Inner radius RI	800 mm	
Conveying angle	90° (others available on request)	
Spacing	5°/number: 18 rollers	
Conveyor frame profile	mk 2255	
Roller types	type 47 and 48	from p. 264
Stand	only with conveyor stand option variant D	from p. 280
Load capacity, standard	depending on the conveyor width and conveyor roller, up to 100 kg/90°	higher on request

Tangential Chain Roller Conveyor RBT-P 2255

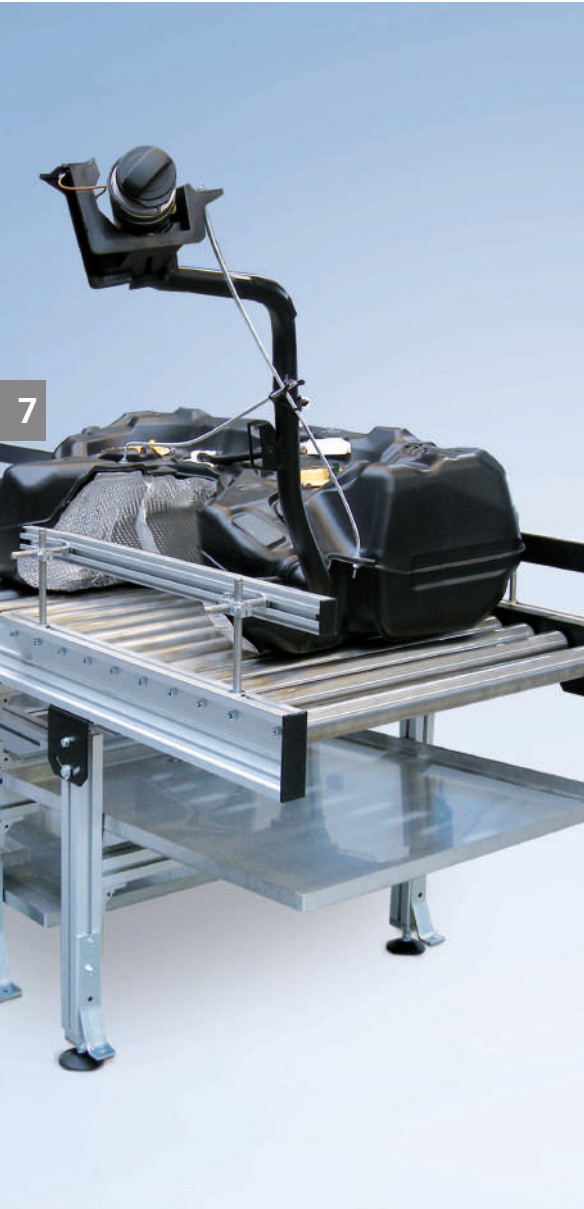

» Straight and curved sections, suitable for even dirty or oily environments. «

The RBT-P 2255 tangential chain roller conveyor is used wherever long conveying paths with a motorised drive mechanism are required. The conveyor is driven by a $\frac{1}{2}$ " chain, which runs within an enclosed, low-wear wear strip to tangentially drive the conveyor rollers from below via a sprocket wheel. This allows you to achieve conveying paths up to 10 m in length and makes the system suitable for even dirty or oily environments.

The chain tail is also equipped with idler pulleys supported by ball bearings for minimal friction losses. The tangential chain roller conveyor is available in both straight and curved configurations and can be combined with other roller conveyors (RBS and RBM). The longitudinal slots in the beam profiles can be used to attach side rails, stands, initiators and other accessories.

Benefits of RBT-P 2255

- Driven by a tangential chain
- For transporting products of moderate weight
- For conveying paths up to 10 m long
- Suitable for even dirty or oily environments
- mk 2255 conveyor frame profile allows for combination with RBS and RBM roller conveyors
- Side slots on the conveyor frame profile for attaching accessories such as side rails, stands, etc.

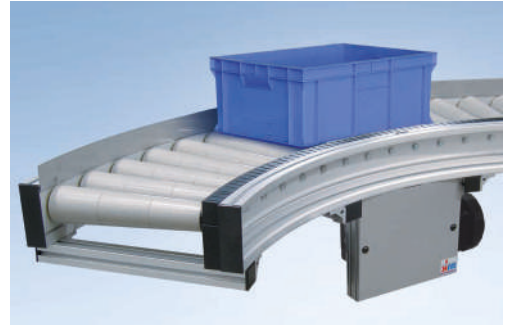

7

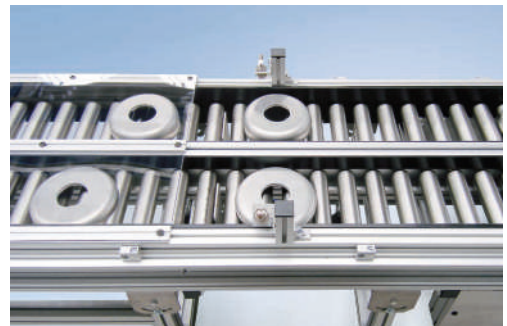

Cross Section

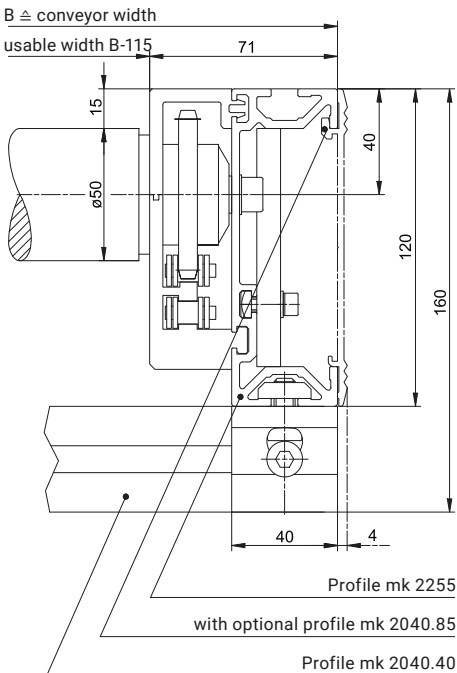

RBT-P 2255 Straight Section

Properties

The tangential chain roller conveyor is based on the mk 2255 profile. The anodised conveyor frame profiles are designed for a spacing of 100 mm and a roller diameter of 50 mm.

B61.02.003

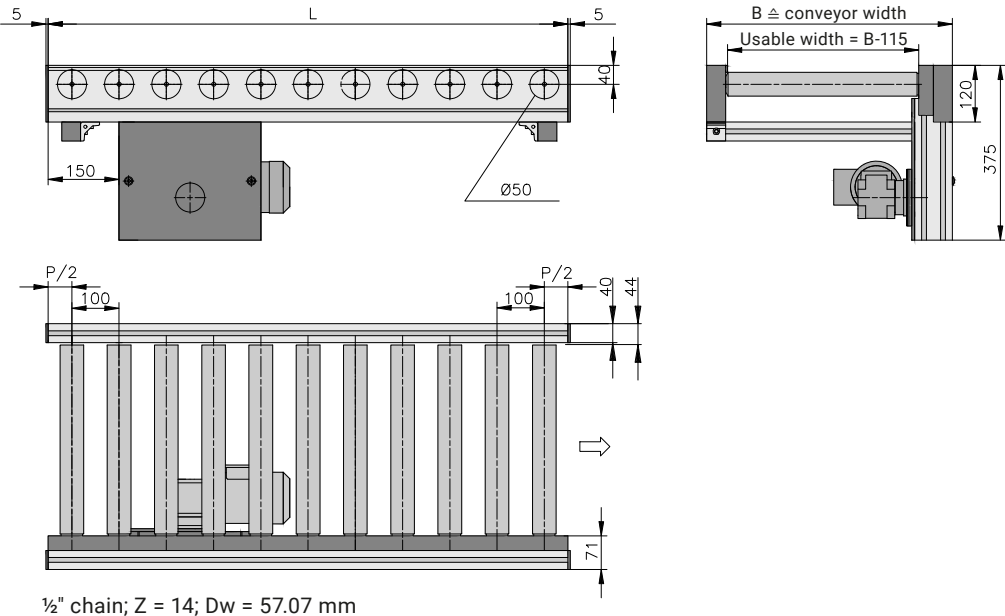

Technical data

Roller diameter	50 mm, made from galvanised steel	
Conveyor width B	320, 420, 520, 620 and 720 mm	others on request
Conveyor length L	600–10000 mm	others on request
Spacing p	100 mm (optionally 75, 150, 200)	others on request
Conveyor frame profile	mk 2255	
Roller types	type 49 and 57, 60 or 61	from p. 264
Speed	up to 30 m/min	p. 12
Stand	only with conveyor stand option variant D	from p. 280
Load capacity, standard	depending on the conveyor width and conveyor roller, up to 100 kg/m and a total load capacity of 400 kg	higher on request

RBT-P 2255 Curved Section

Properties

The curve builds on the straight line with a cylindrical \varnothing 50 mm roller. The curve is fitted with conical elements based on the radii. The speed specifications refer to the middle of the conveyor. For quiet running, the rollers in the standard version are designed with a 5% partition.

B61.02.004

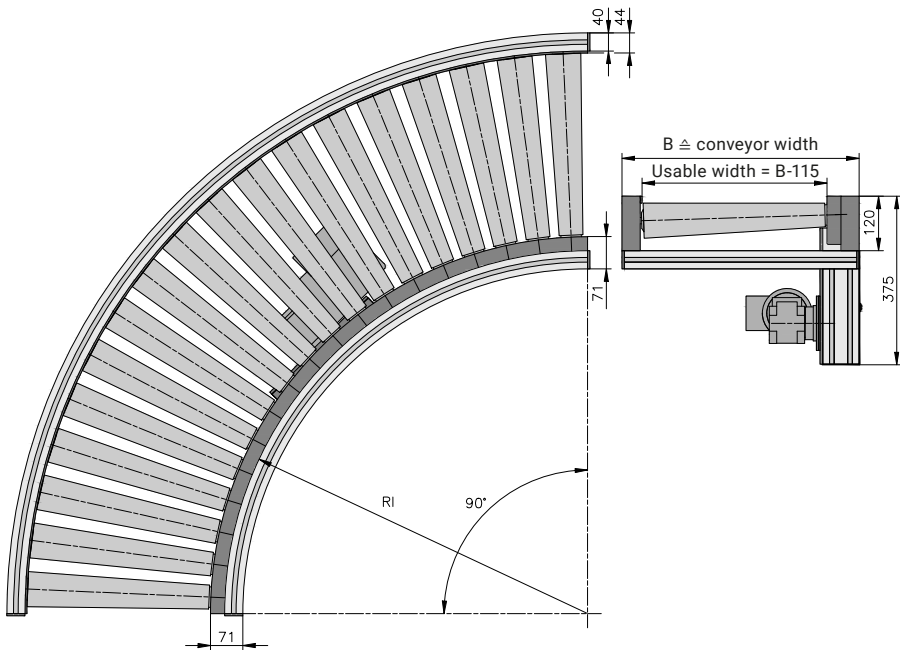

Technical data

Roller diameter	50 mm, conical, made from plastic	
Conveyor width B	420, 520, 620 and 720 mm	
Inner radius RI	800 mm	
Conveying angle	90°	others on request
Spacing	5°/number: 18 rollers	
Conveyor frame profile	mk 2255	
Roller types	type 50	from p. 264
Speed	up to 30 m/min	p. 12
Stand	only with conveyor stand option variant D	from p. 280
Load capacity, standard	depending on the conveyor width and conveyor roller, up to 100 kg/90°	higher on request

Drive Roller Conveyor RBM-P 2255



» Straight and curved sections for variable speeds and with a start/stop function. «

The drive roller in the RBM-P 2255 drive roller conveyor allows you to drive up to nine additional rollers using the round belt. By segmenting the drive mechanisms in this way, this type of roller conveyor allows you to implement different speeds or start/stop functions within a single conveying path. This gives you the ability to separate, stop and buffer product, allowing you to achieve even complex material flows when combined with appropriate control technology. A control module controls the speed and direction of rotation.

The RBM-P 2255 roller conveyor is notable for its few obstructing edges and easy-to-clean design, making it well suited for clean environments and increased sanitary requirements. It is also available in an IP66 version on request, or with an electronic holding brake for upward and downward gradients.

The roller conveyor is available in both straight and curved configurations and can be combined with other roller conveyors (RBS and RBT). The longitudinal slots in the beam profiles can be used to attach side rails, stands, initiators and other accessories.

Benefits of RBM-P 2255

- Powered by a drive roller
- For transporting products of moderate weight
- Equipped with a round belt for driving up to 9 additional rollers
- Different speeds or start/stop functions possible in a single conveying path
- Few obstructing edges and maximum conveyor width
- mk 2255 conveyor frame profile allows for combination with RBS and RBT roller conveyors
- Side slots on the conveyor frame profile for attaching accessories such as side rails, stands, etc.



7

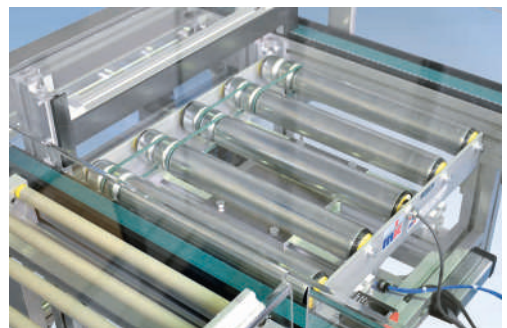

Cross Section

$B \triangleq$ conveyor width
 usable width B-88

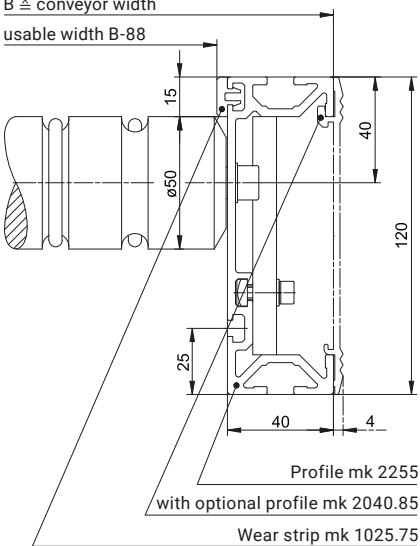

RBM-P 2255 Straight Section

Properties

The drive roller conveyor is based on the mk 2255 profile. The anodised conveyor frame profiles are designed for a spacing of 100 mm and a roller diameter of 50 mm. A maximum of five rollers per drive roller are connected and driven by round belts upstream and downstream of the drive roller. We recommend using one drive roller per metre with the spacing $p = 100$ mm.

B61.02.005

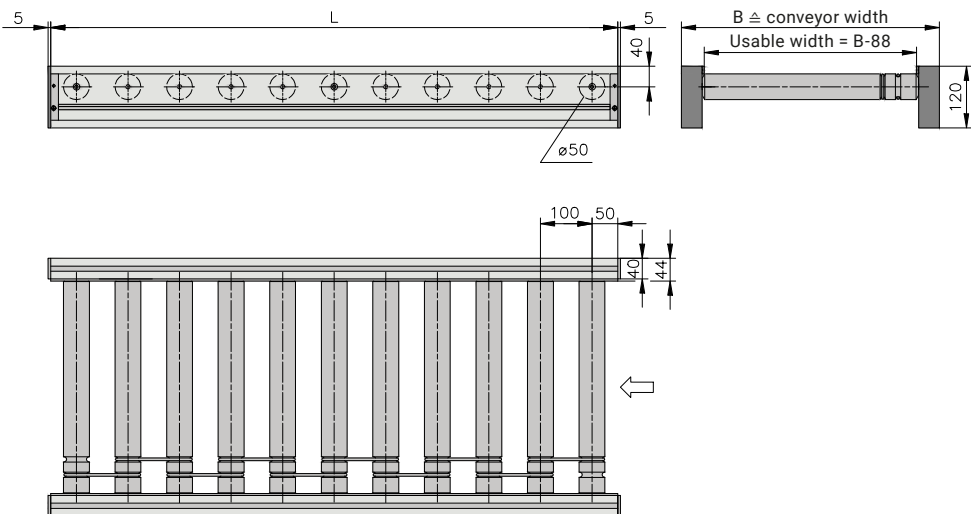

Technical data

Roller diameter	50 mm, made from galvanised steel	
Conveyor width B	480, 580 and 680 mm	others on request
Conveyor length L	500–10000 mm	
Spacing p	100 mm	
Conveyor frame profile	mk 2255	
Roller types	type 51, 55 and 66	from p. 264
Speed	up to 70 m/min	p. 12
Stand	only with conveyor stand option variant D	from p. 280
Load capacity, standard	depending on the gear ratio of the drive rollers and number of installed drives, max. 100 kg/m	i=9:1 for 6–70 m/min: 3 kg i=16:1 for 4–60 m/min: 5 kg i=48:1 for 1.5–20 m/min: 15 kg i=96:1 for 0.6–9 m/min: 30 kg

RBM-P 2255 Curved Section

Properties

The curve builds on the straight line with a cylindrical \varnothing 50 mm roller. The curve is fitted with conical elements based on the radii. The speed specifications refer to the middle of the conveyor. For quiet running, the rollers in the standard version are designed with a 5% partition.

B61.02.006

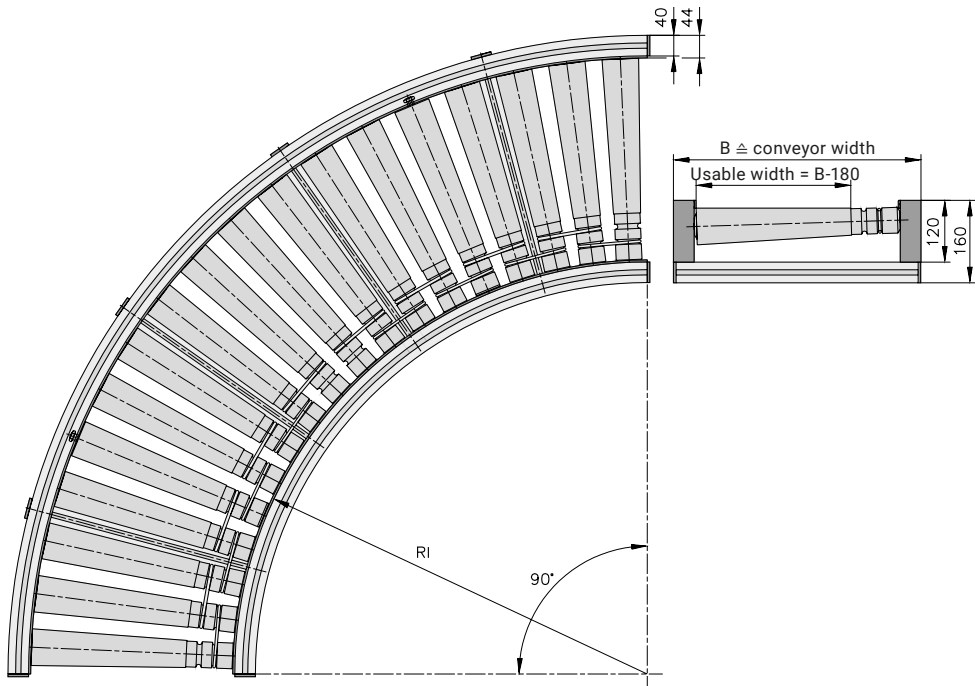

Technical data

Roller diameter	50 mm, conical, made from plastic	
Conveyor width B	480, 580 and 680 mm	
Inner radius RI	800 mm	
Spacing	5°/number: 18 rollers	
Conveyor frame profile	mk 2255	
Roller types	type 52, 56 and 67	from p. 264
Speed	up to 30 m/min	p. 12
Stand	only with conveyor stand option variant D	from p. 280
Load capacity, standard	depending on the conveyor width and conveyor roller, up to 55 kg/90°	higher on request

Rollers

Gravity rollers are non-driven support rollers. They are used for universal roller conveyors where products are transported by hand or using gravity on downward gradients.

Gravity Rollers for RBS-P 2065/2066 and RBS-P 2255, Cylindrical

Roller	∅	Colour	Usable width*	Material	Mounting	Friction	Load/roll
Type 43	50 mm	Grey	B-50 B-88	Plastic	M8 female thread	-	7–35 kg
Type 44	50 mm	Grey	B-50 B-88	Plastic	Spring axle, ∅ 8 mm	-	7–35 kg
Type 45	50 mm	Silver	B-50 B-88	Galv. steel	M8 female thread	-	35 kg
Type 46	50 mm	Silver	B-50 B-88	Galv. steel	Spring axle, ∅ 8 mm	-	35 kg
Type 58	20 mm	Grey	B-50 B-88	Plastic	Spring axle, ∅ 6 mm	-	1–8 kg
Type 59	40 mm	Grey	B-50 B-88	Plastic	Spring axle, ∅ 8 mm	-	10–18 kg
Type 64	20 mm	Silver	B-50 B-88	Stainless steel	Spring axle, ∅ 6 mm	-	9 kg

Gravity Rollers for RBS-P 2065/2066 and RBS-P 2255, Conical

Roller	∅	Colour	Usable width*	Material	Mounting	Friction	Load/roll
Type 47	50 mm	Grey	B-50 B-88	Plastic	M8 female thread	-	40 kg
Type 48	50 mm	Grey	B-50 B-88	Plastic	Spring axle, ∅ 8 mm	-	40 kg

*For RBS-P 2065 and RBS-P 2066 | RBS-P 2255

Rollers driven by a tangential chain are suitable for loads with a low to moderate weight. They are suitable for dirty or oily environments.

Driven Rollers with Sprocket Wheel for RBT-P 2255, Cylindrical

Roller	∅	Colour	Usable width	Material	Mounting	Friction	Load/roll
Type 49	50 mm	Silver	B-115	Galv. steel	M8 female thread	-	40 kg
Type 57*	50 mm	Silver	B-115	Galv. steel	M8 female thread	One end	30 kg
Type 60*	50 mm	Silver	B-115	Galv. steel	M8 female thread	Both ends	30 kg
Type 61*	50 mm	Silver	B-115	Galv. steel	M8 female thread	Adjustable	40 kg

Driven Rollers with Sprocket Wheel for RBT-P 2255, Conical

Roller	∅	Colour	Usable width	Material	Mounting	Friction	Load/roll
Type 50	50 mm	Grey	B-115	Plastic	M8 female thread	-	40 kg

*Friction rollers can be used only with conveyed products with a smooth and firm surface

Drive rollers are rollers that provide a maximum usable width and minimal obstructing edges. Separately driven sections allow for different speeds and start/stop functions.

Drive Rollers for RBM-P 2255, Cylindrical

Roller	∅	Colour	Usable width*	Material	Mounting	Friction	Load/roll
Type 66*	50 mm	Silver	B-88	Galv. steel	M8 female thread, M12x1 male thread	-	30 kg

Drive Rollers for RBM-P 2255, Conical

Roller	∅	Colour	Usable width*	Material	Mounting	Friction	Load/roll
Type 67*	50 mm	Grey	B-180	Plastic	M8 female thread, M12x1 male thread	-	30 kg

Rollers for RBM-P 2255, Cylindrical

Roller	∅	Colour	Usable width*	Material	Mounting	Friction	Load/roll
Type 51	50 mm	Silver	B-88	Galv. steel	M8 female thread	-	30 kg
Type 55	50 mm	Silver	B-88	Galv. steel	Spring axle, ∅ 8 mm	-	30 kg

Rollers for RBM-P 2255, Conical

Roller	∅	Colour	Usable width*	Material	Mounting	Friction	Load/roll
Type 52	50 mm	Grey	B-180	Plastic	M8 female thread	-	30 kg
Type 56	50 mm	Grey	B-180	Plastic	Spring axle, ∅ 8 mm	-	30 kg

*Drive roller with 450 mm cable including plug. Cable can be extended up to 10 m. Speed of the motorized roller regulated by drive control. Drive control and extension cable must be ordered separately.

Drive control for drive rollers

Rated voltage 24 V DC, voltage range 18–26 V, rated current 2 A, max. 5 A, degree of protection IP 54. Also available in IP 20 on request, for installation in control cabinets. Includes fastening accessories.

Drive control for drive rollers, type 66 **B46.10.001**
 Drive control for drive rollers, type 67 **B46.10.002**

Extension cable (2 m) **K106066VK54**
 (max. 5 x 2 m per drive roller permitted)

Order designation

Ident. no. **K106 /... /....**
 Roller type (e.g. type 57 = 057)
 Installation length EL (e.g. 450 mm = 0450)

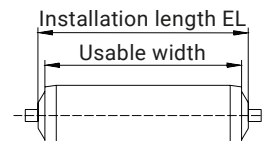

Application Examples

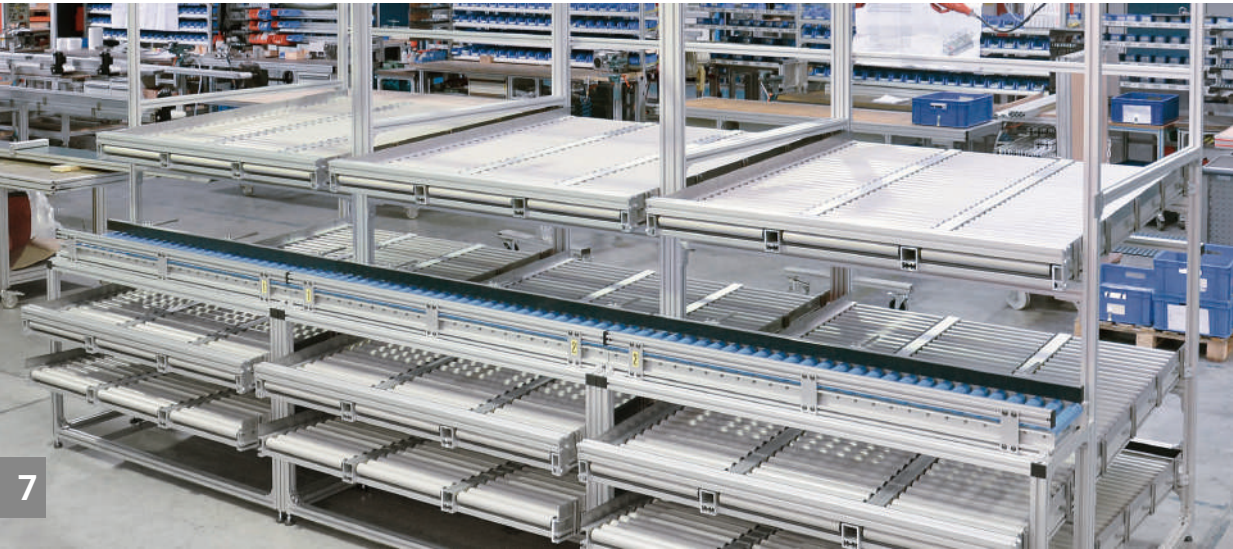

Kanban workstation with RBS-P 2065 gravity conveyors for feeding products



Gravity roller conveyor RBS-P 2066 with 45° curve



Gravity roller conveyor RBS-P 2065 with 12° incline



7

Roller conveyor RBT-P 2066 with vertical shaft drive and diagonal rollers for centring the workpiece on one side



Gravity roller conveyor RBS-P 2066 with height-adjustable stand and angle plate as side rail



Gravity roller conveyor RBS-P 2065 as feed and discharge conveyor for laundry baskets

Application Examples



7

Friction roller conveyor RBT-P 2255 with oscillating conveyor operating as a lift for returning empty baskets

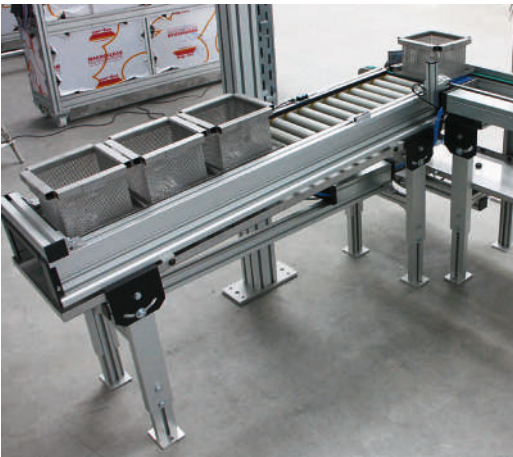

RBS-P 2255 with drip pan and integrated discharge chute below the conveyor

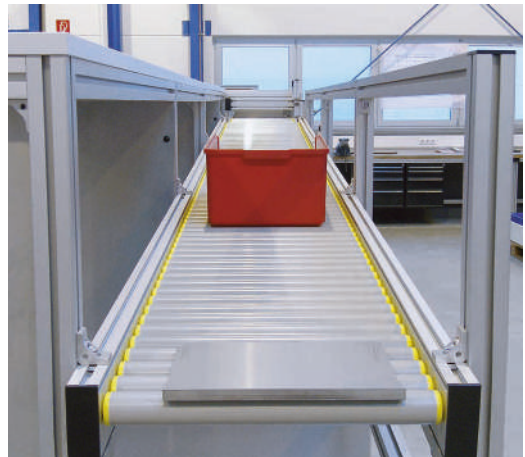

RBS-P 2255 with plastic rollers with \varnothing 40 mm

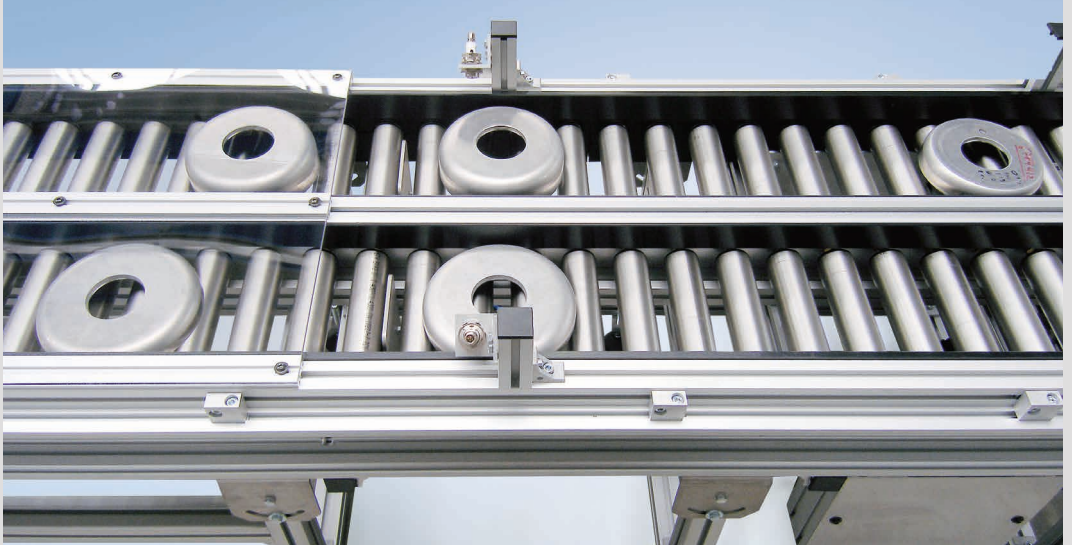

7

RBS-P 2255 as parallel provisioning conveyor for removal by a robot



Transport belt combination RBT-P 2255 with integrated lift-and-transfer conveyor



Combination of rotary table and RBT-P 2255 with buffer table for picking tasks and \varnothing 50 mm steel rollers

Application Examples



RBT-P 2255 with integrated lift-and-transfer conveyor, 100 kg/m load capacity with additional side rail and drip pan

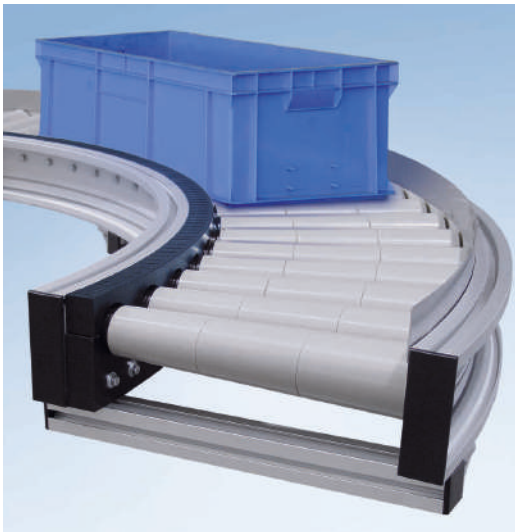

RBT-P 2255 as 90° curve

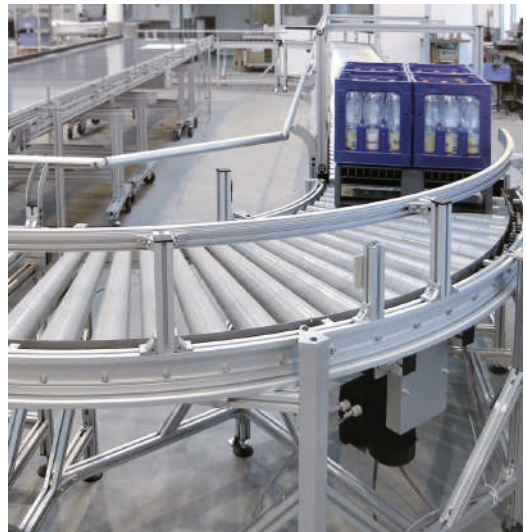

Driven curved roller conveyor RBT-P 2255 90°

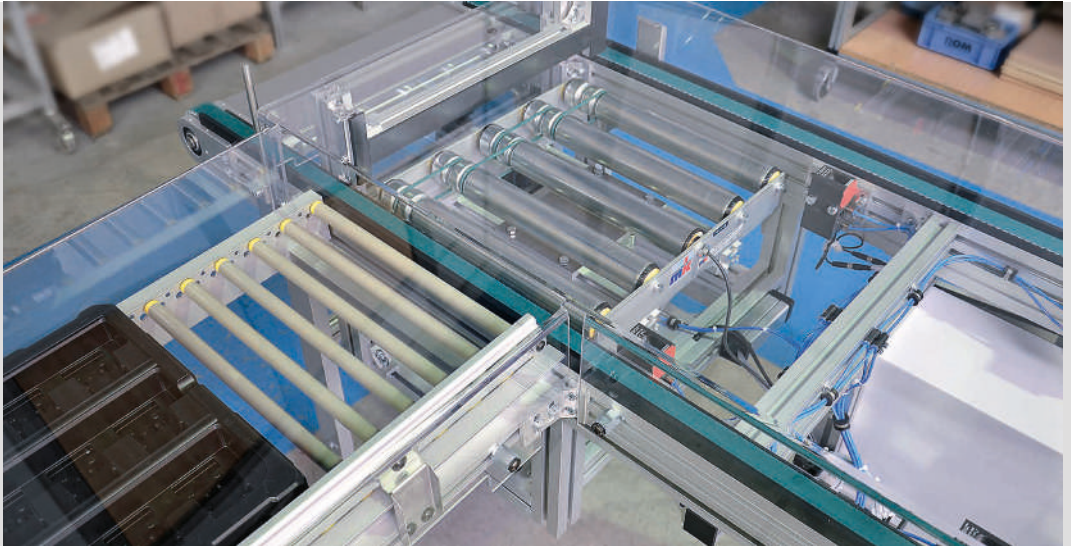

7

RBM-P 2255 drive roller conveyor as a lift-and-transfer conveyor with control module, with belt discharge via RBS-P 2065 gravity roller conveyor



Interlink with RBM-P 2255 driven roller conveyors and RBS-P 2066 gravity roller conveyors for mail crates

Chapter 8 Rotary Tables



Rotary Tables

DTZ-P 2040

274



Application Examples

276

Rotary Table DTZ-P 2040

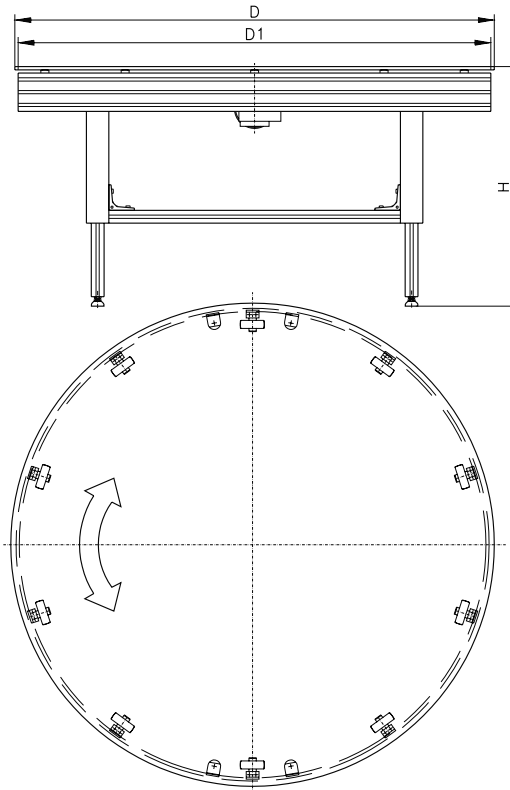

8

Technical data

Rotary table Ø	D1 = 750, 1000, 1250, 1500 mm	others on request
Rotary table top		p. 275
Drive version	chain	special designs available on request
v const (U/min)	1 – 8 U/min	others on request
Load	100 kg	
Side rails		on request
Height H	H = 500 – 1500 mm	others on request

Table Tops

The table tops listed below are standard versions. Special versions are available on request.

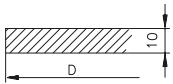

Variant 1.1
Laminated top

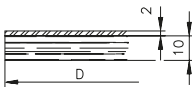

Variant 1.2
Laminated top
With VA steel shelf

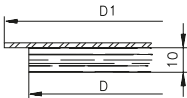

Variant 1.3
Laminated top
with protruding
VA steel shelf
(for short workpieces)

Infeed and Discharge Designs

The designs below are standard versions that can be combined. For all the designs, you can choose either clockwise or anti-clockwise rotation.

When designing diverters, the weight and shape of the product being conveyed plays a major role. mk therefore creates the technical design of the diverters based on the customer's specific requirements. With extensive experience in interlinking and conveying applications, mk can draw on a wealth of previously implemented solutions. For example, we can implement adjustable diverter plates that are integrated into the control system.

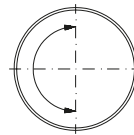

Design A

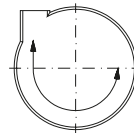

Design B
Left slide bed

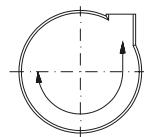

Design C
Right slide bed

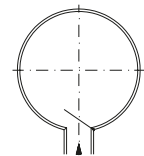

Design D
Central slide bed

Sample order

DTZ-P 2040 Design C

D1 = 1000 mm

H = 800 mm

Table top variant 1.1

v = 2 U/min anti-clockwise rotation

Application Examples

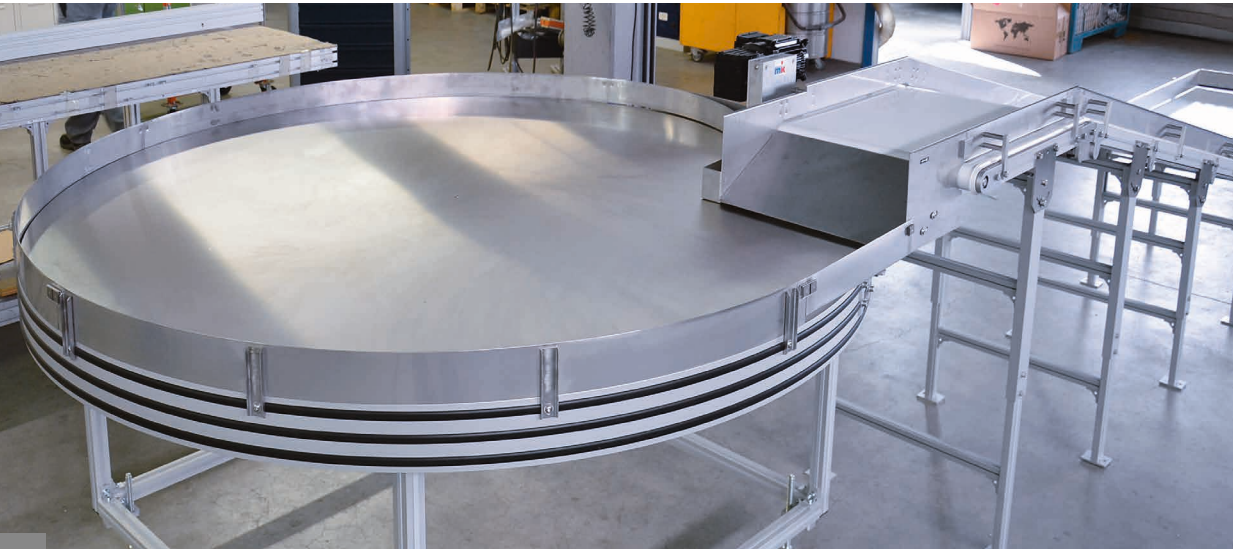

8

Rotary table with timing belt drive (\varnothing 2000 mm), application in the pharmaceutical industry



Rotary table with additional custom add-on



Rotary table with covered support frame



Lightweight and cost-efficient mobile rotary table



Rotary table with timing belt drive and belt conveyor, all with electrical height adjustment using the telescopic column

8



Rotary table with friction belt drive



Rotary table with direct drive, stainless steel sheet around the perimeter and single-track discharge

Chapter 9 Conveyor Technology Accessories



Stands

Stand Versions and Conveyor	
Stand Fastening Elements	280
Pad Options	281
Single Stands	282
Stand, Lightweight	285
Stand, Medium-Weight	289
Stand, Heavy-Duty	293

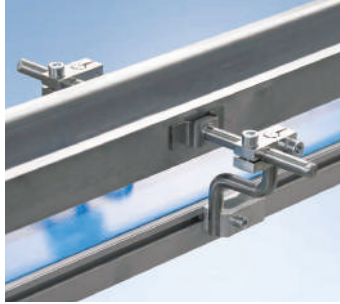

Side Rails

Fixed Side Rails	294
Adjustable Side Rails	295
Individual Components	297



Nuts

300

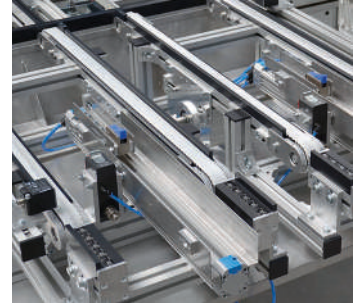
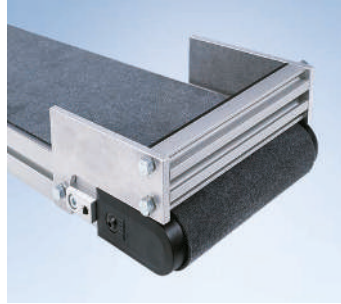
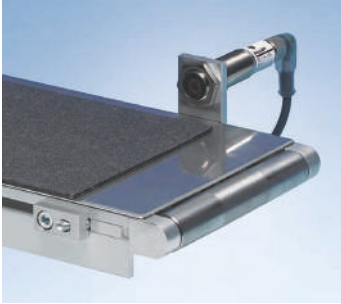

Electrical Components

Reglomats
 Initiators

302
 303

Other Accessories

End Stops
 Drip Pan

304
 305

Application Examples

306

Stand Versions

mk delivers the right stand system for every type of conveyor. For system stability, please take into account the ratio of height to width, the centre of gravity of the load and other influences. We would be happy to advise you on the optimal configuration, or you can use our online configurator (www.quickdesigner.com).

Example of a single stand

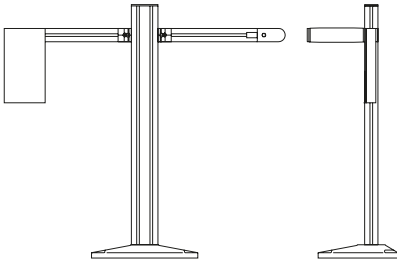

Example of a height-adjustable stand

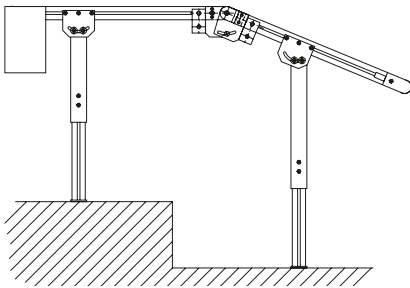

Example of a stand with a special design

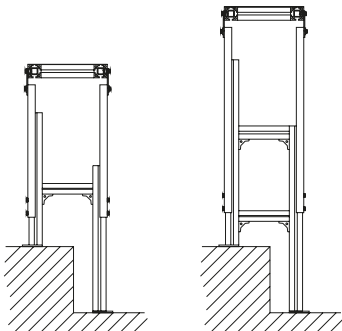

Conveyor Stand Fastening Elements

The conveyor stand fastening elements connect the conveyor to the stand. Various fastening elements with different adjustment angles can be selected.

Example of fastening variant A, 20°

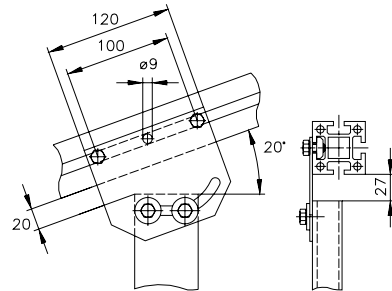

Example of fastening variant B, 45°

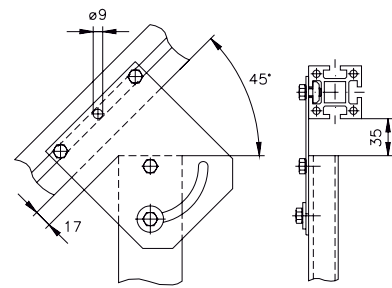

Example of fastening variant C, 60°

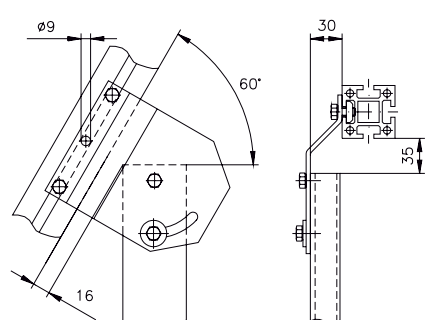



Pad Options

A variety of pad options are available depending on the stand that is selected. Examples include levelling feet, floor plates for anchoring or fixed castors and swivel casters.

Example of a floor plate

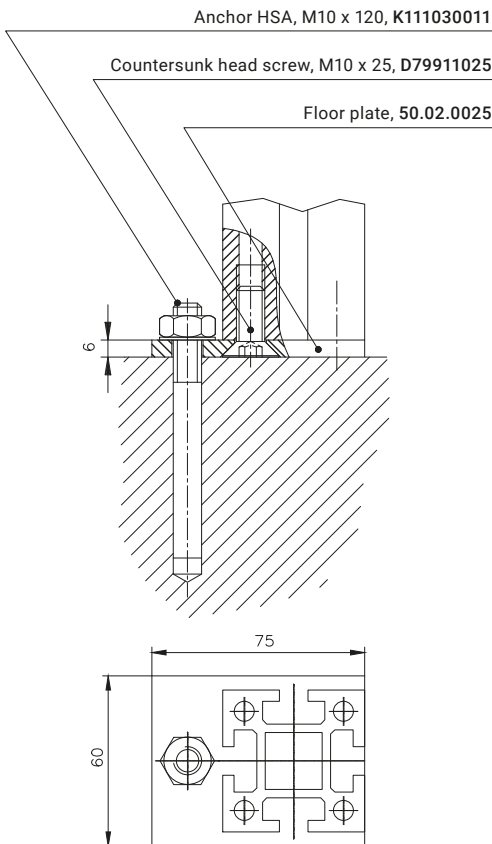

Example of fixed and swivel casters, type A

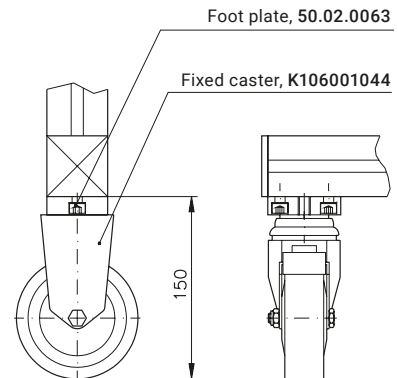

Example of a levelling foot, ø79 M16

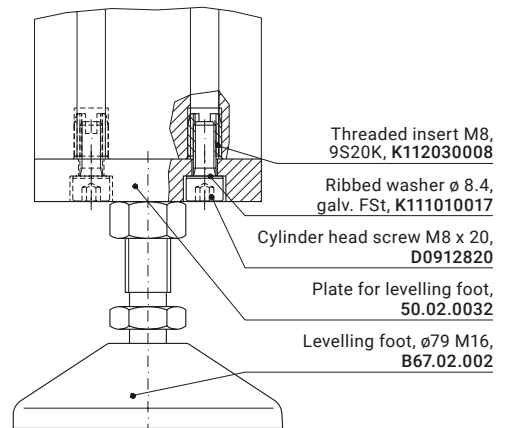

Stands

Single Stands

Stand 54.80

Single stand with profile mk 2040.41 for conveyors up to 250 mm wide. Can be used for belt conveyors GUF-P MINI and GUF-P 2000 and modular belt conveyor MBF-P 2040.

Ident. no. B67.04.080

Standard heights:

- H 500 mm
- H 750 mm
- H 1000 mm
- H 1250 mm
- H 1500 mm

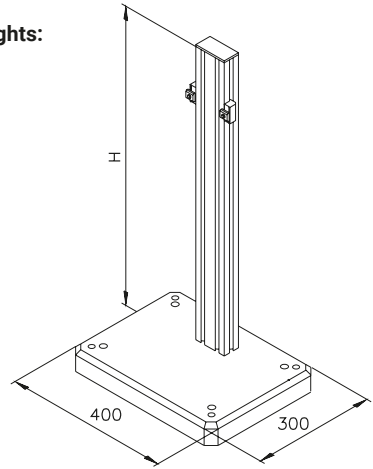

Stand 51.2

Single stand with profile mk 2004 for conveyors up to 250 mm wide. Can be used for belt conveyors GUF-P MINI, GUF-P 2000 and MBF-P 2040.

Ident. no. B67.04.002

Standard heights:

- H 500 mm
- H 750 mm
- H 1000 mm
- H 1250 mm
- H 1500 mm

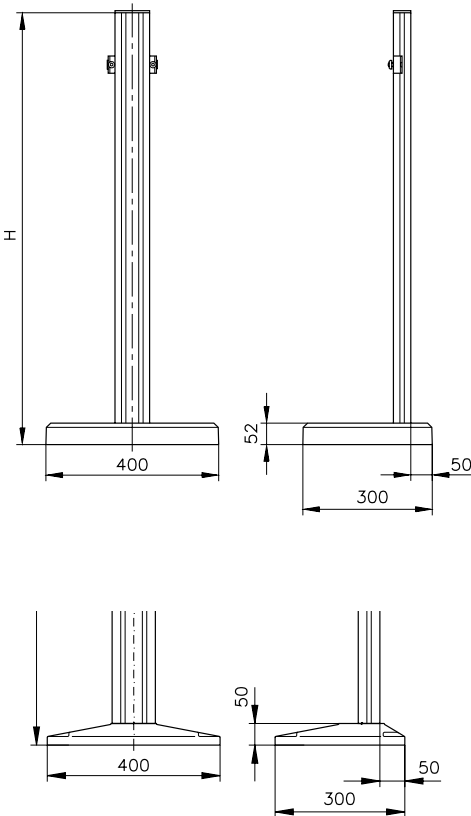
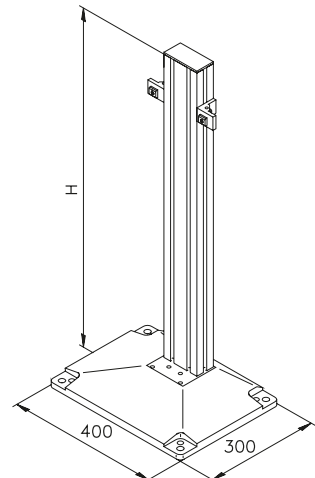

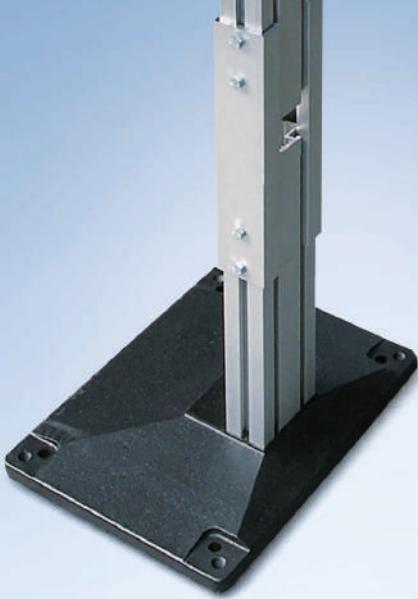

Single Stands

Floor fastening element for single stand

As floor fastening elements for single stands, base plates ensure stability, come with a black paint finish as standard and have a defined drilling pattern for facilitating anchoring to the floor.

Base Plate 7, 50.02.0089

Grey cast-iron material, painted black

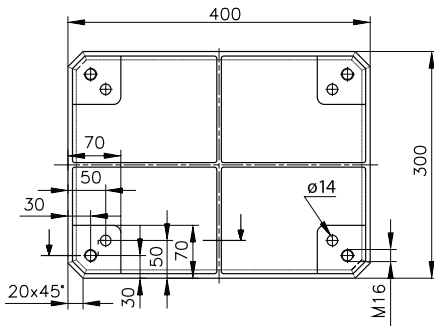

Adjusting screw DIN 916, 8.8 galv.,
M16 x 60, D09161660

Anchor HSA, M10 x 120,
K111030011

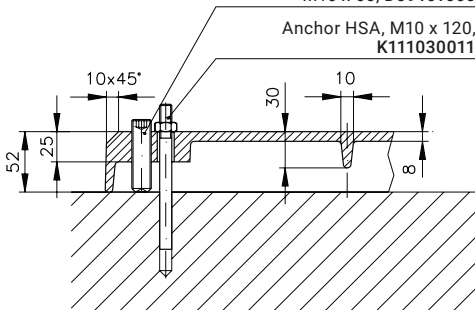

Base Plate 1, 50.02.0023

Grey cast-iron material, painted matt black

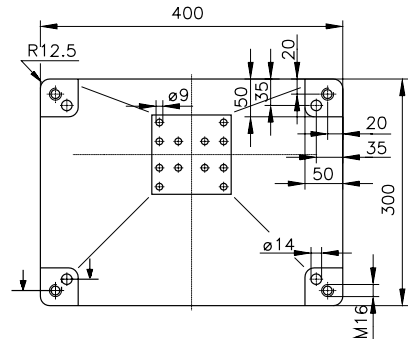

Adjusting screw DIN 916, 8.8 galv.,
M16 x 40, D09161640

Anchor HSA, M10 x 120,
K111030011

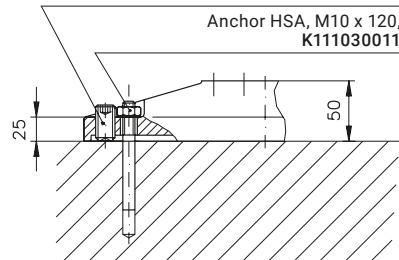

Stands

Single Stands

Stand 52.5

Height of single stand can be adjusted with mk 2000 profile. Can be used for flat top chain conveyor SBF-P 2254.

Ident. no. B67.05.008

Standard heights:

H 500 mm – 1500 mm
± 50 mm

Standard width:

B 100 mm
B 130 mm
B 205 mm

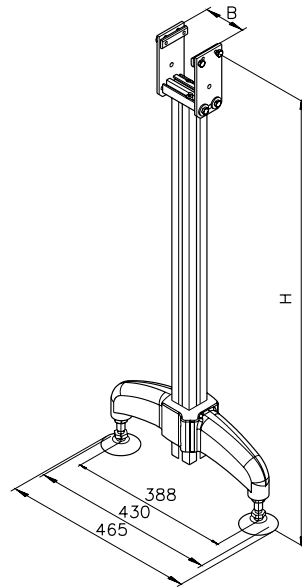
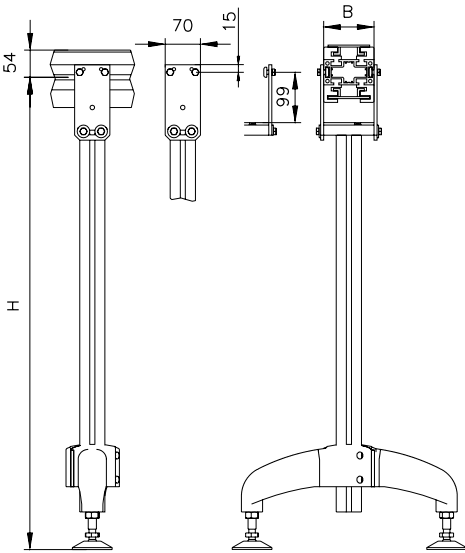

Stand, Lightweight

Stand 55.1

Lightweight stand in simple H design with mk 2040.40 profile (light duty). Can be used for virtually all conveyor systems, except curved conveyors and incline conveyors.

Ident. no. B67.06.011

Standard heights:

H 500 mm
 H 750 mm
 H 1000 mm
 H 1200 mm

Standard width:

B = 200 – 1200 mm

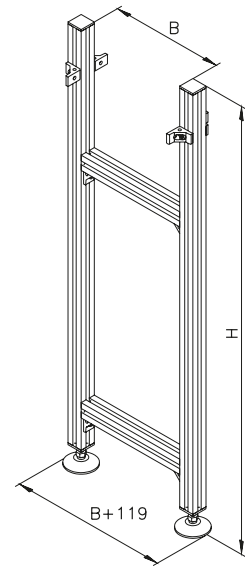
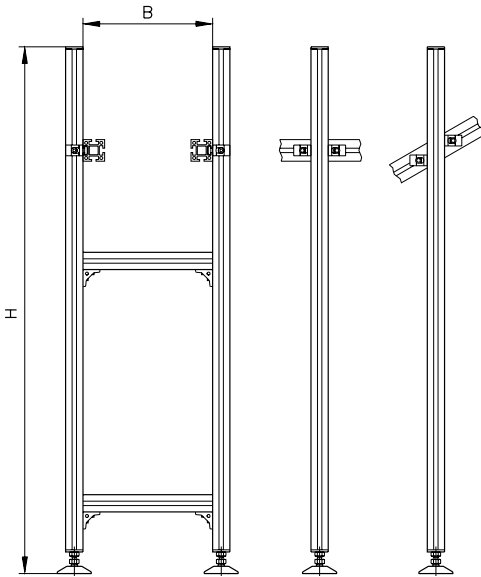

Stands

Stand, Lightweight

Stand 53.1

Lightweight height-adjustable stand in H design with mk 2001 profile. Can be used for virtually all conveyor systems, except curved conveyors and incline conveyors.

Ident. no. B67.06.001

Standard heights with adjustment range:

- H 325 mm ± 25 mm
- H 400 mm ± 50 mm
- H 550 mm ± 100 mm
- H 700 mm ± 150 mm

Standard width:

B = 200 – 800 mm

For H 700 mm or higher,
uses 2 traverses

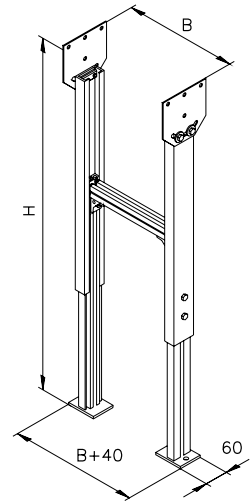
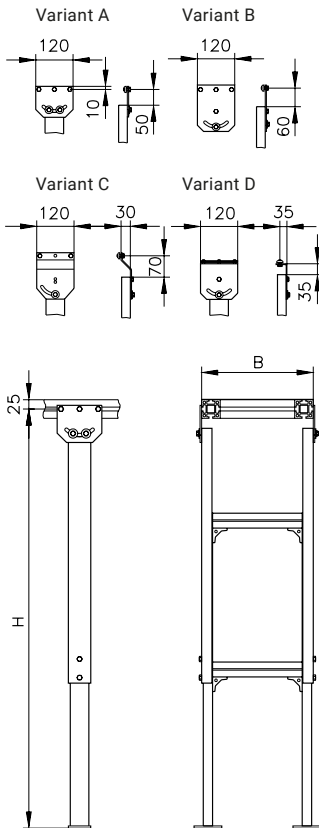

Stand, Lightweight

Stand 53.11

Lightweight height-adjustable stand with base traverse in H design with mk 2001 profile. Can be used for virtually all conveyor systems, except curved conveyors and incline conveyors. The stand is suitable for fixed casters and swivel casters.

Ident. no. B67.06.002

Standard heights with adjustment range:

- H 400 mm ± 25 mm
- H 450 mm ± 25 mm
- H 500 mm ± 50 mm
- H 600 mm ± 50 mm
- H 700 mm ± 100 mm
- H 800 mm ± 150 mm

Standard width:

B = 100 – 500 mm

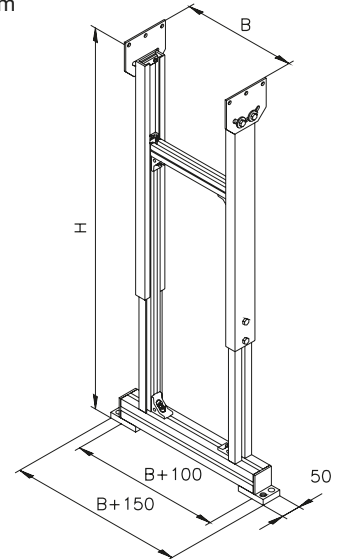
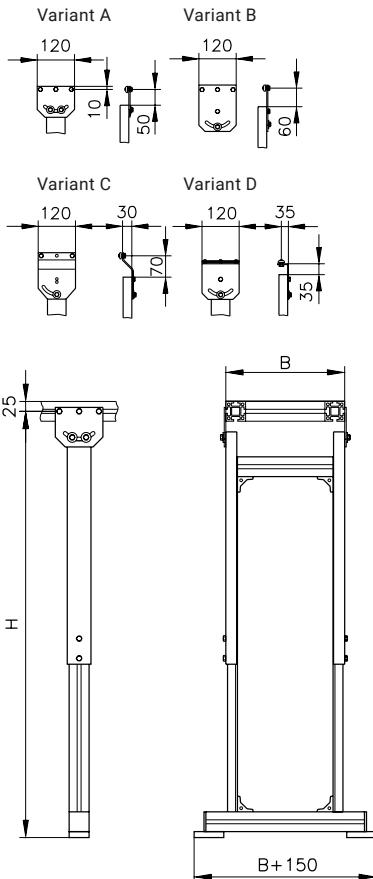

Stands

Stand, Lightweight

Stand 53.11, Mobile

Lightweight height-adjustable stand with base traverse in mobile H design with mk 2001 profile. Can be used for virtually all conveyor systems, except curved conveyors and incline conveyors.

Ident. no. B67.06.100

Standard heights with adjustment range:

H 600 mm ± 25 mm

H 700 mm ± 50 mm

H 800 mm ± 100 mm

Standard width:

B = 100 – 500 mm

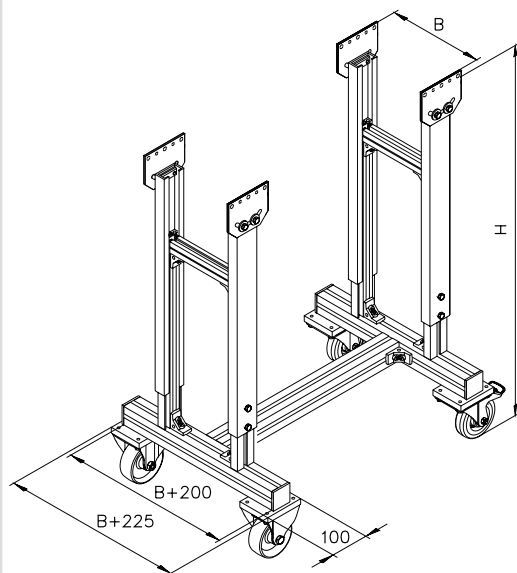
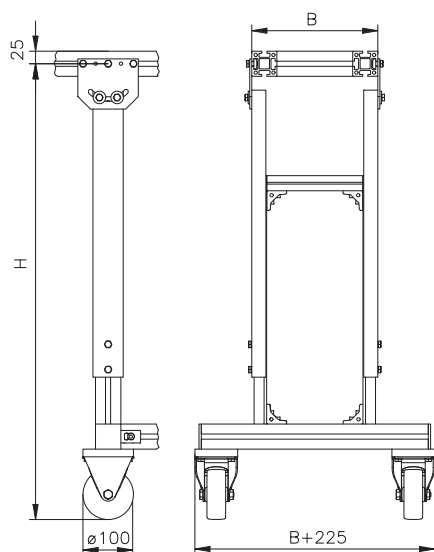
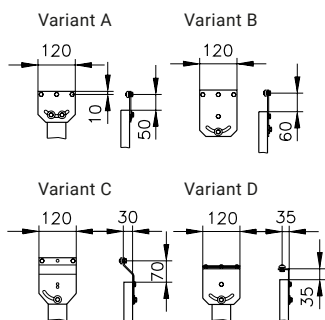

Stand, Medium-Weight

Stand 53.2

Medium-weight height-adjustable stand in H design with mk 2014 profile. Can be used for virtually all conveyor systems, except curved conveyors and incline conveyors.

Ident. no. B67.06.003

Standard heights with adjustment range:

- H 325 mm ± 25 mm
- H 400 mm ± 50 mm
- H 550 mm ± 100 mm
- H 700 mm ± 150 mm
- H 850 mm ± 200 mm
- H 1000 mm ± 200 mm
- H 1200 mm ± 200 mm

Standard width:

B = 200 – 1500 mm

For H 700 mm or higher,
 uses 2 traverses

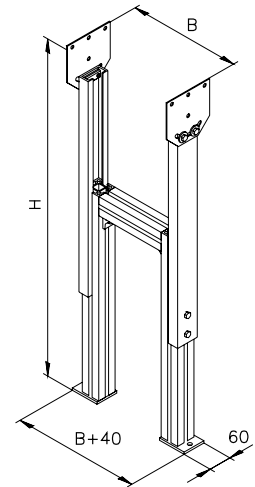
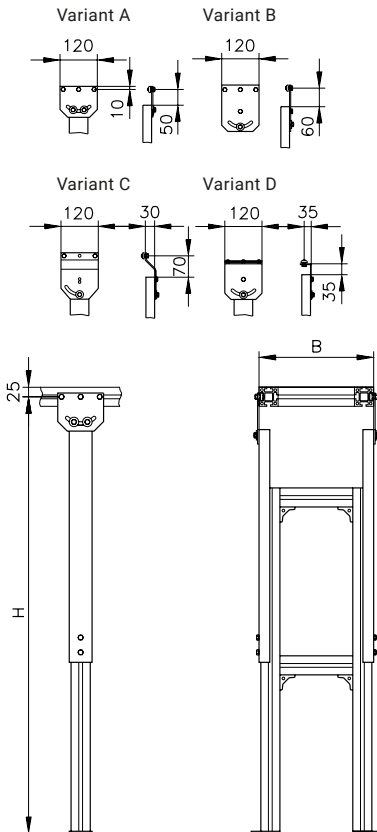

Stands

Stand, Medium-Weight

Stand 53.21

Medium-weight height-adjustable stand with base traverse in H design with mk 2014 profile. Can be used for virtually all conveyor systems, except curved conveyors and incline conveyors. The stand is suitable for fixed casters and swivel casters.

Ident. no. B67.06.004

Standard heights with adjustment range:

- H 400 mm ± 25 mm
- H 450 mm ± 25 mm
- H 500 mm ± 50 mm
- H 600 mm ± 50 mm
- H 700 mm ± 100 mm
- H 800 mm ± 150 mm
- H 1000 mm ± 200 mm
- H 1200 mm ± 200 mm

Standard width:

B = 200 – 800 mm

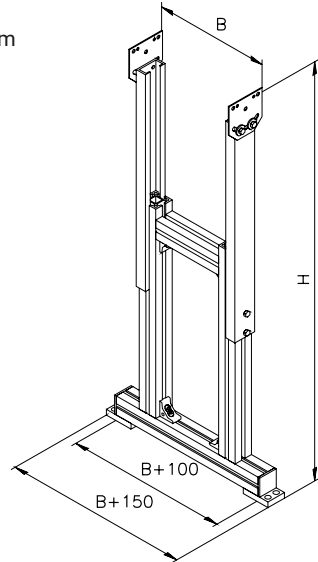
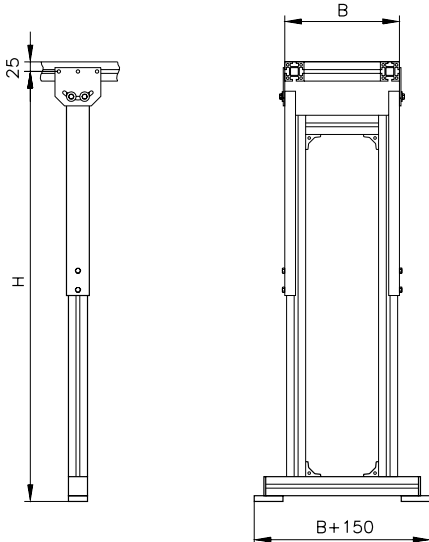
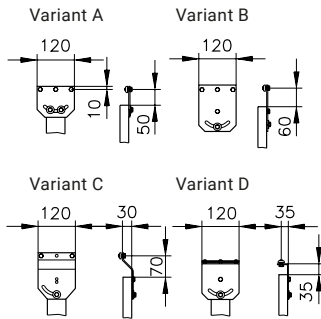



Stand, Medium-Weight

Stand 53.21, Mobile

Medium-weight height-adjustable stand with base traverse in mobile H design with mk 2014 profile. Can be used for virtually all conveyor systems, except curved conveyors and incline conveyors.

Ident. no. B67.06.101

Standard heights with adjustment range:

- H 600 mm ± 25 mm
- H 700 mm ± 50 mm
- H 800 mm ± 100 mm
- H 1000 mm ± 150 mm
- H 1200 mm ± 200 mm

Standard width:

B = 200 – 800 mm

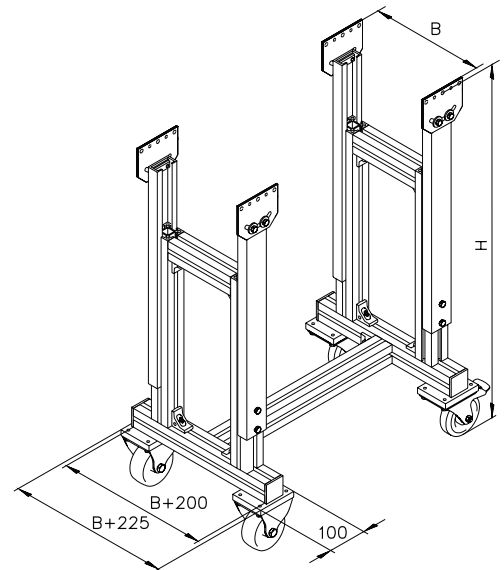
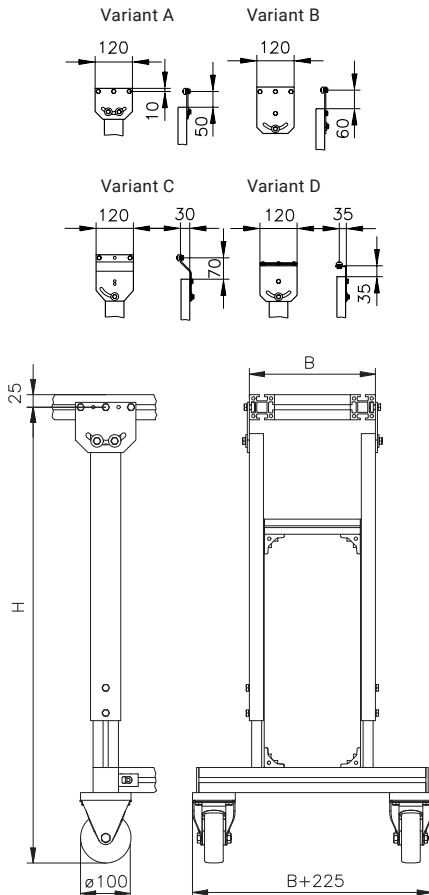

Stands

Stand, Medium-Weight

Stand 53.32

Medium-weight height-adjustable stand with base traverse in H design with mk 2014 profile. Can be used for virtually all conveyor systems, except curved conveyors and incline conveyors.

Ident. no. B67.06.016

Standard heights with adjustment range:

- H 450 mm ± 25 mm
- H 500 mm ± 50 mm
- H 600 mm ± 50 mm
- H 700 mm ± 100 mm
- H 800 mm ± 150 mm
- H 1000 mm ± 200 mm

Standard width:

- B = 300 –1000 mm
- B1 = B-10
- B2 = 460, 660 mm

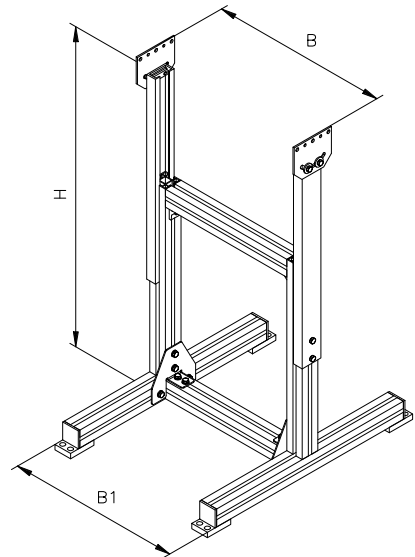
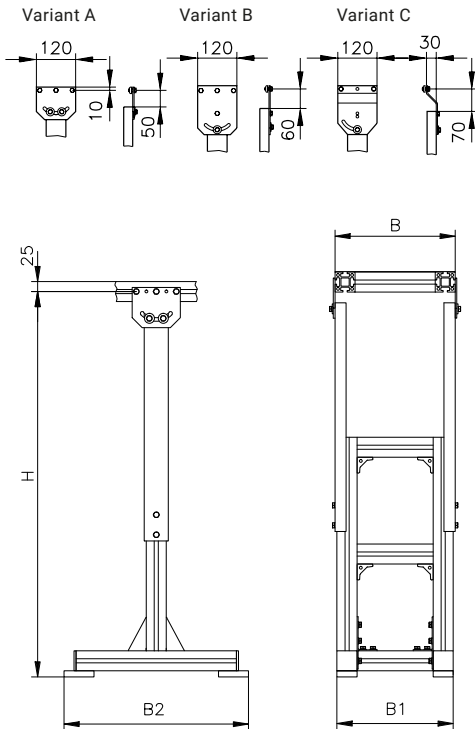



Stand, Heavy-Duty

Stand 31

Heavy-duty height-adjustable stand in H design with mk 2031 profile. Can be used for virtually all conveyor systems, except curved conveyors and incline conveyors.

Ident. no. B67.03.002

Standard heights with adjustment range:

- H 325 mm ± 25 mm
- H 400 mm ± 50 mm
- H 550 mm ± 100 mm
- H 700 mm ± 150 mm
- H 850 mm ± 200 mm
- H 1000 mm ± 250 mm
- H 1150 mm ± 300 mm
- H 1500 mm ± 300 mm
- H 2000 mm ± 300 mm

Standard width:

B = 500 – 2000 mm

For H 1150 mm or higher, uses 2 traverses

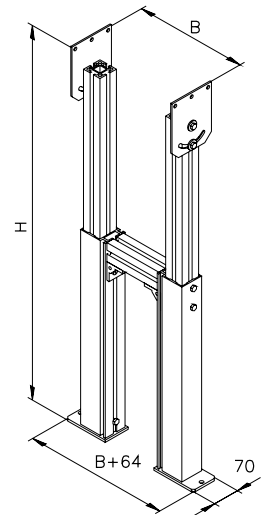
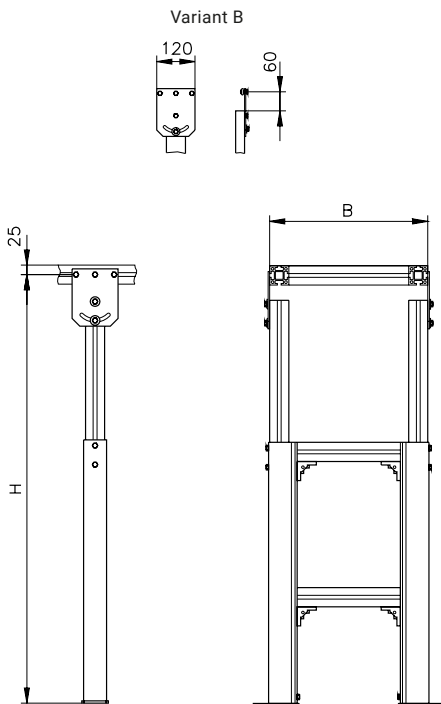

Side Rails

Fixed Side Rails

Side Rail SF1.3

B17.00.003

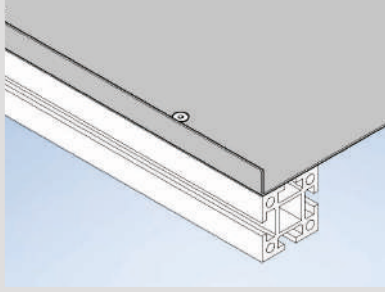

H = 10–100 mm

The length of this side rail is limited to the length of the slide bed and is therefore shorter than the conveyor length L. It cannot be removed.

Only available for belt conveyors!

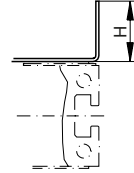

Side Rail SF2.1

B17.00.004

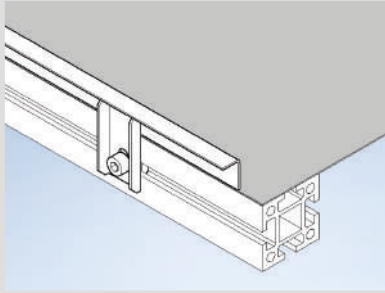

L1 = 25, 50, 75 mm

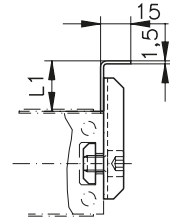

Side Rail SF2.2

B17.00.005

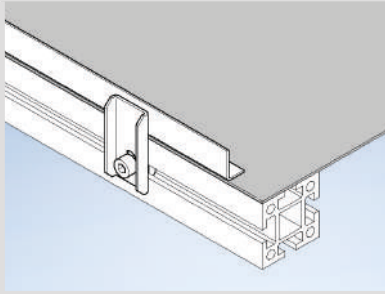

L1 = 25, 50, 75 mm

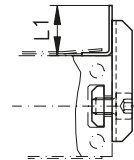

Adjustable Side Rails

Side rail SF01

B17.00.101

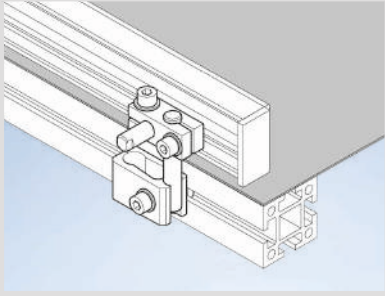

Separate holder HSF01
B27.01.001

L14 = 50, 75, 100 mm
 L16 = 75, 100, 150, 200 mm

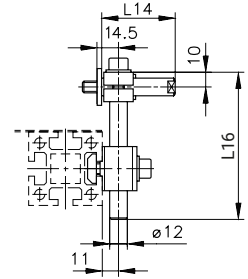

Side rail SF02

B17.00.102

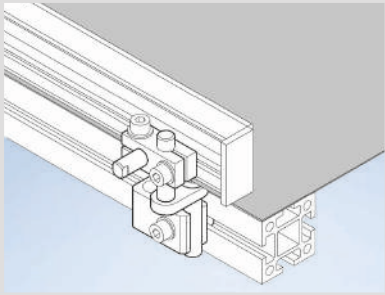

Separate holder HSF02
B27.01.002

L12 = 50, 75, 100, 150 mm
 L13 = 25, 50 mm

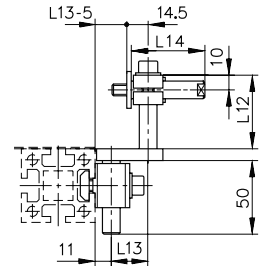

Side rail SF03

B17.00.103

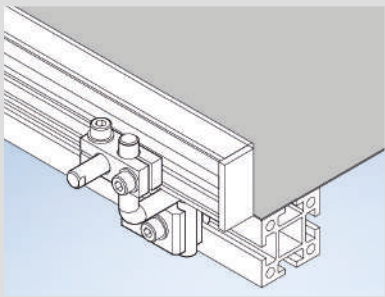

Separate holder HSF03
B27.01.003

L16 = 100, 150, 200

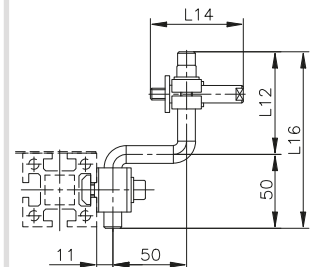

Side Rail Strips

Type 01
B17.01.013

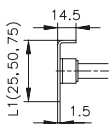

Type 11
B17.01.017

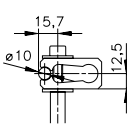

Type 12
B17.01.018

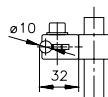

Type 21
B17.01.010

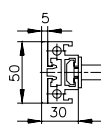

Type 22
B17.01.014



Type 23
B17.01.015



Type 24
B17.01.016

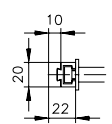

Side Rails

Adjustable Side Rail for SBF-P 2254

Side rail for flat top chain conveyor

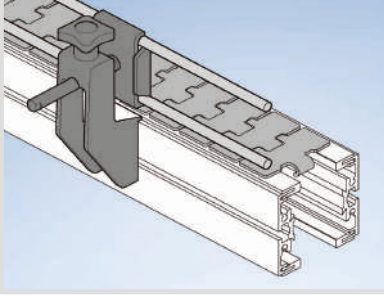

System SF10.1 **B17.00.020**
for straight section

System SF10.2 **B17.00.021**
for curved section

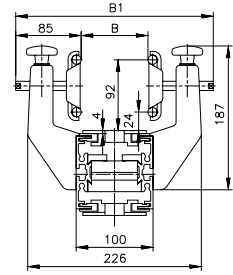

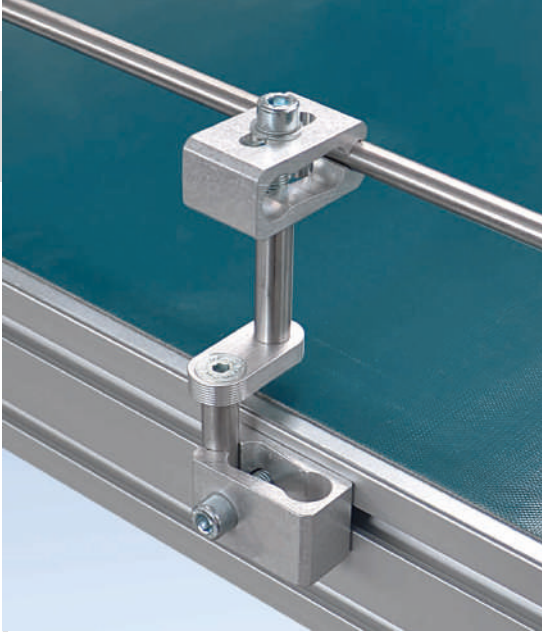

Individual Components

Clamps for round rods

Material: Tumbled aluminium

Side walls for round rods

Material: Tumbled aluminium

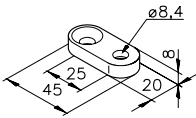

Side wall
34.09.0003

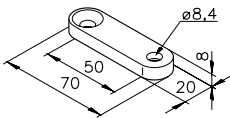

Side wall
34.09.0004

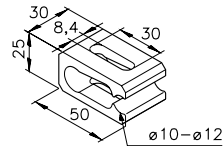

Clamp
30.00.0002

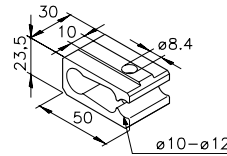

Clamp
30.00.0001

For 10 mm slot width

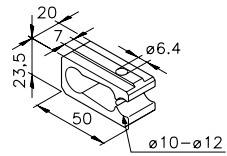

Clamp
30.00.0017

For 7 mm slot width

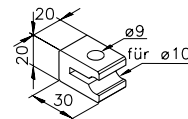

Short clamp
30.00.0038

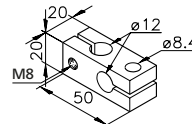

Clamp, right
30.00.0013

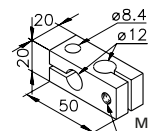

Clamp, left
30.00.0047

Side Rails

Individual Components

Swivel Clamps

Swivel clamps allow for a wide variety of angle and height connections for the guide rods.

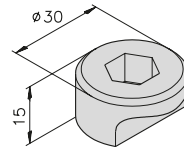

Clamp
mk 2522

PA6GF 30%,
glass fibre reinforced

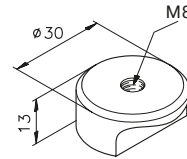

Clamp
30.00.0024

stainless steel 1.4305

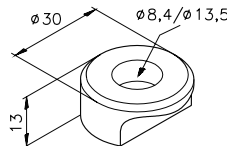

Clamp
30.00.0023

stainless steel 1.4305

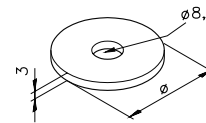

Washer, \varnothing 30
63.00.0016

stainless steel 1.4305

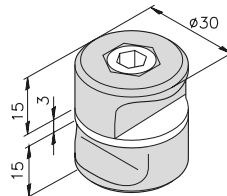

Clamp, complete
B46.02.005

PA6GF 30%,
glass fibre reinforced

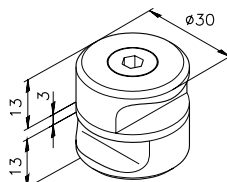

Clamp, complete
B46.02.004

stainless steel 1.4305

Stainless steel clamp, 30.00.0023
Plastic clamp, mk 2522

Cylinder head screw M8 x 20,
D0912820

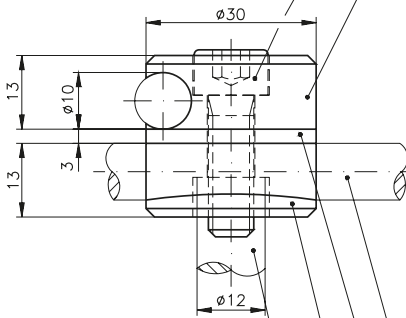

Rod, M8 \varnothing 12, 7000AA*

Stainless steel clamp, 30.00.0023
Plastic clamp, mk 2522

Washer, 63.00.0016

Rod, \varnothing 10, 7000AB*

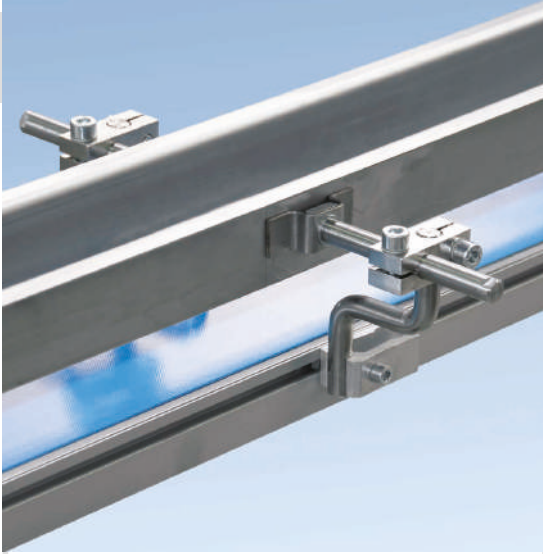

Individual Components

Round Rods

Material: Stainless steel

Rod, ϕ 12
7000AD.*

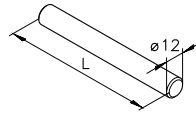

2-chamfer

stock length 50, 75, 100,
 150, 200 and 250 mm

Rod, ϕ 12
7000AA....*

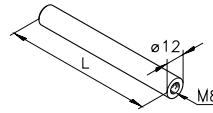

M8 female thread, one end
 stock length 50, 75, 100,
 150 and 200 mm

Guide rod, ϕ 12
7000AF.*

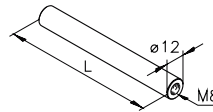

M8 female thread, both ends
 stock length 50, 75, 100
 and 150 mm

Guide rod, ϕ 12
7000DB.*

male thread, M8, one end
 stock length 100, 150 and
 200 mm

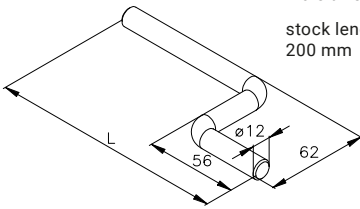

Guide rod, ϕ 12
7000CC.*

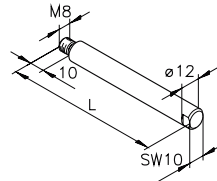

male thread, M8, one end
 stock length 50, 75 and
 100 mm

Guide rod, ϕ 12
7000CA.*

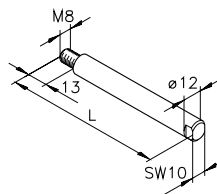

male thread, M8, one end
 stock length 50, 75 and
 100 mm

* Length in mm (4 digits)

Nuts

Nuts for connecting accessories such as initiators, stoppers, holders, and so on, can be ordered.

Material: Galvanised steel

Nuts for Profile Slot, 10 mm

(all systems except for GUF-P MINI)

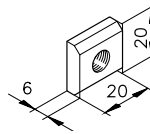

Nut 1
M6 34.02.0008

M8 34.01.0001

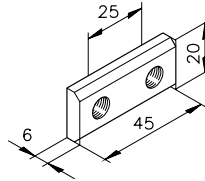

Nut 2/25
M6 34.02.0010

M8 34.01.0002

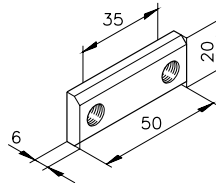

Nut 2/35
M8 34.01.0011

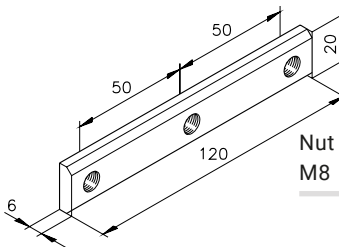

Nut 3/50
M8 34.01.0006

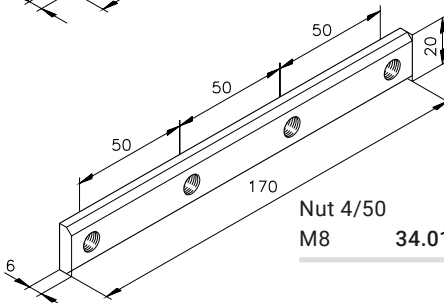

Nut 4/50
M8 34.01.0007

Nuts for Profile Slot, 7 mm

(GUF-P MINI)

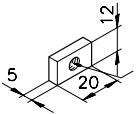

Nut 1 without chamfer
M6 34.02.0001

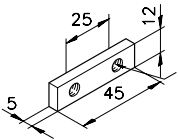

Nut 2/25
M6 34.02.0002

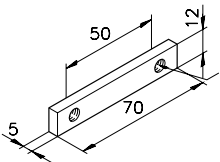

Nut 2/50
M6 34.02.0003

Nuts for Profile Slot, 10 mm

(all systems except for GUF-P MINI)

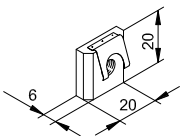

Nut 1 with spring sheet
M6 34.02.0051

M8 34.01.0051



Nut 1 ESD with spring sheet
M6 34.02.0050

M8 34.01.0050



Retrofit Nuts

Retrofit nuts can be slotted into the profile slot after the assembly has been completed. In addition, they can be used for profiles with closed slots that are only open where the connection is located. The swivel-in nuts with spring sheet also provide an ESD function and an attachment in the slot.

Material: Galvanised steel

Nuts for Profile Slot, 10 mm

(all systems except for GUF-P MINI)

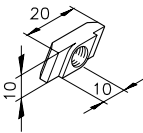

T-nut	
M4	34.07.0004
M5	34.07.0003
M6	34.07.0002
M8	34.06.0002

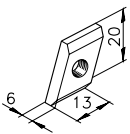

Slot nut	
M6	34.04.0003
M8	34.03.0002

stainless steel

Earth Terminal

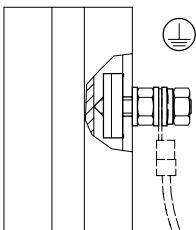



 Earth Terminal B02.99.151

Nuts for Profile Slot, 10 mm

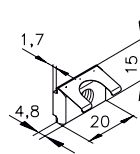
(all systems except for GUF-P MINI)



 Swivel-in nut 1 ESD with spring sheet	
M4	34.16.0431
M5	34.16.0531
M6	34.16.0631
M8	34.16.0831

 Swivel-in nut 1 ESD with spring sheet	
M5	34.16.0537
M6	34.16.0637
M8	34.16.0837

stainless steel

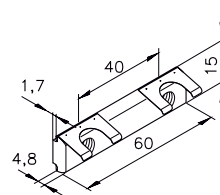

 Swivel-in nut 2/40 ESD with spring sheet	
M8	34.16.0834

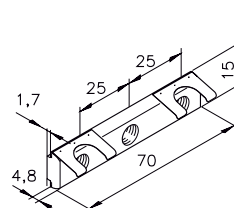

 Swivel-in nut 3/25 ESD with spring sheet	
M8	34.16.0835

Electrical Components

Reglomats

The integration of conveyor systems into existing processes is becoming more and more complex. At the customer's request, mk can supply complete solutions from the control concept to hand-over at the customer's premises. We can also implement wiring to terminal boxes, I/O modules or bus systems based on customer specifications. Even for small controllers, mk can draw from an extensive portfolio of standard components.

The mk reglomat lets you control the conveyor speed within a range of 1:7 (10–70 Hz), assuming an alternating current and the nominal speed at 50 Hz. With direct current, the range is 1:6 (0.25–1.5 A or 0.5–3 A).



Reglomats for direct current motor

- Power supply: Alternating current 230 V 50 Hz
- Adjustment range: 1:6 (0.25-1.5 A or 0.5-3 A)
- Analogue input, DC 0 to +10 V
- Digital input for enable
- Digital output 24 V DC/50 mA
- All digital and analogue signals can be also be controlled externally
- W x H x D = 200 x 300 x 160 mm

Reglomats for three-phase motors

- Power supply: Alternating current 230 V 50 Hz
- Adjustment range: 1:7 (10-70 Hz)
- Analogue input, DC 0 to +10 V
- Three digital inputs (for instance, for enabling, reversing the direction of rotation, photoelectric sensors, and so on)
- Digital output 24 V DC/50 mA
- W x H x D = 200 x 300 x 160 mm

Item no.	Designation	Note
B16.08.000	Reglomat 180DC-3A	Up to 0.25 KW
B16.08.001	Reglomat 180DC-3ARV	180/200V DC

Version RV = with reverse operation

Reglomats for 24 V DC motors can be supplied on request.

Item no.	Designation	Note
B16.08.100	Reglomat 230AC-250	Up to 0.18 KW
B16.08.101	Reglomat 230AC-250RV	motor power
B16.08.102	Reglomat 230AC-370	Up to 0.25 KW
B16.08.103	Reglomat 230AC-370RV	motor power
B16.08.104	Reglomat 230AC-550	Up to 0.37 KW
B16.08.105	Reglomat 230AC-550RV	motor power
B16.08.106	Reglomat 230AC-750	Up to 0.55 KW
B16.08.107	Reglomat 230AC-750RV	motor power

Version RV = with reverse operation



Initiators

Initiators are used to control, position and monitor processes in automation technology. The initiators used in mk conveyor technology consist of four components: the inductive sensor, the clamp mount, the sensor cable and the initiator holder.

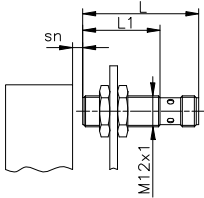

Inductive sensor M12x1

Item no.	L [mm]	L1 [mm]	sn [mm]
K309000124	45	30	4
K308000009	45	30	2
K308000010	70	40	4

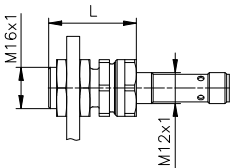

Clamp mount for M12x1 sensors

Item no.	L [mm]
K309000052	34
K309000053	44.5

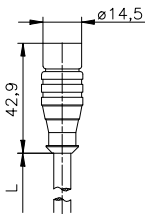

Sensor cable with bushing*, M12x1, straight

Item no.	L [m]
K307000002	5

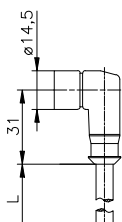

Sensor cable with bushing*, M12x1, angled

Item no.	L [m]
K307000018	5
K307000017	10

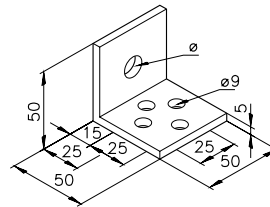

Initiator holder A

Item no.	
16.00.0000	ø 13
16.00.0001	ø 19
16.05.0011	R1/4"

tumbled Al

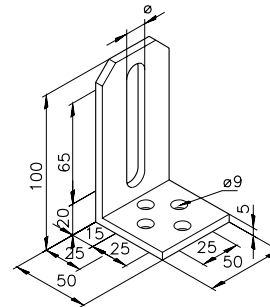

Initiator holder B

Item no.	
16.00.0006	ø 13
16.00.0007	ø 19

tumbled Al

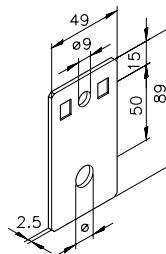

Initiator holder C

Item no.	
16.00.0011	ø 9
16.00.0012	ø 13
16.00.0013	ø 19

galv. steel

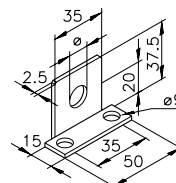

Initiator holder E

Item no.	
16.00.0026	ø 9
16.00.0027	ø 13
16.00.0028	ø 19

galv. steel

* Other end is open cable

Other Accessories

End Stops

Product on the conveyor often needs to be stopped for production reasons, especially on belt conveyors and roller conveyors. mk offers its end stop for this very purpose. It is easy to mount on the conveyor frame in the system slots on the conveyor frame profile. The end stop is equipped with a plastic strip to avoid damaging the product.

End stop GUF-P 2000
B66.00.004

incl. fastening accessories

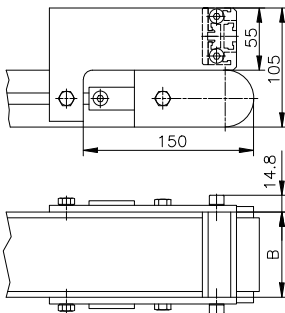
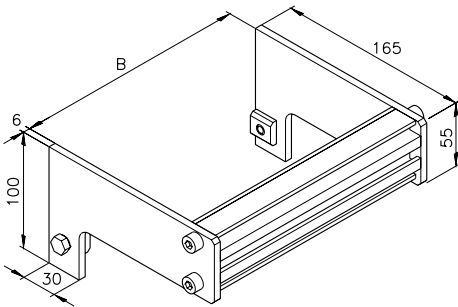

Belt conveyor GUF-P 2000

End stop RBS-P 2065/66
B66.00.003

incl. fastening accessories

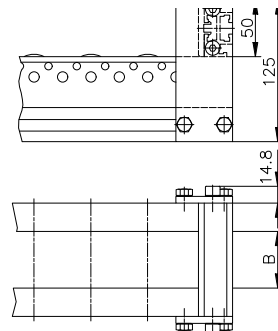
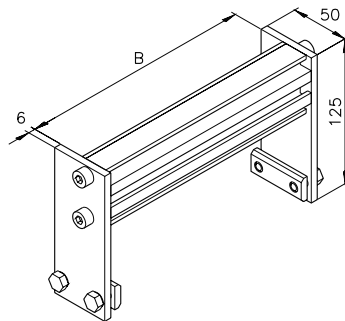

Roller conveyor RBS-P 2065



Drip Pan

The stainless steel drip pan is primarily intended for belt and modular belt conveyors, and its length, width and depth can be adapted to your particular conveyor system. It is equipped with a drain nozzle with an R3/4 thread that can be connected to the drain lines. Typical applications include conveying products that are only lightly coated in oil.

Drip pans are always designed and built to order.

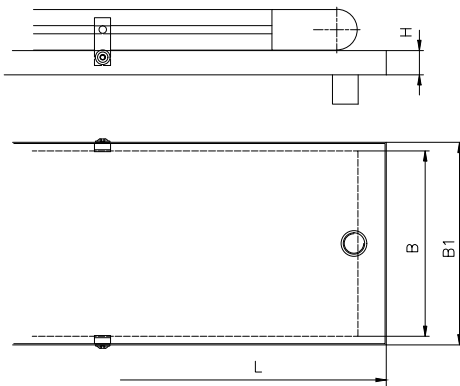

Example of the simplest solution

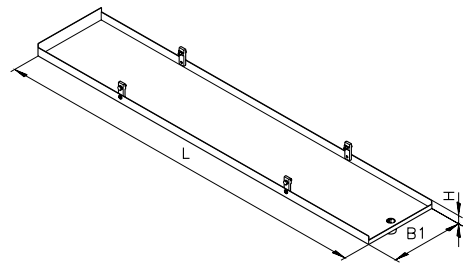

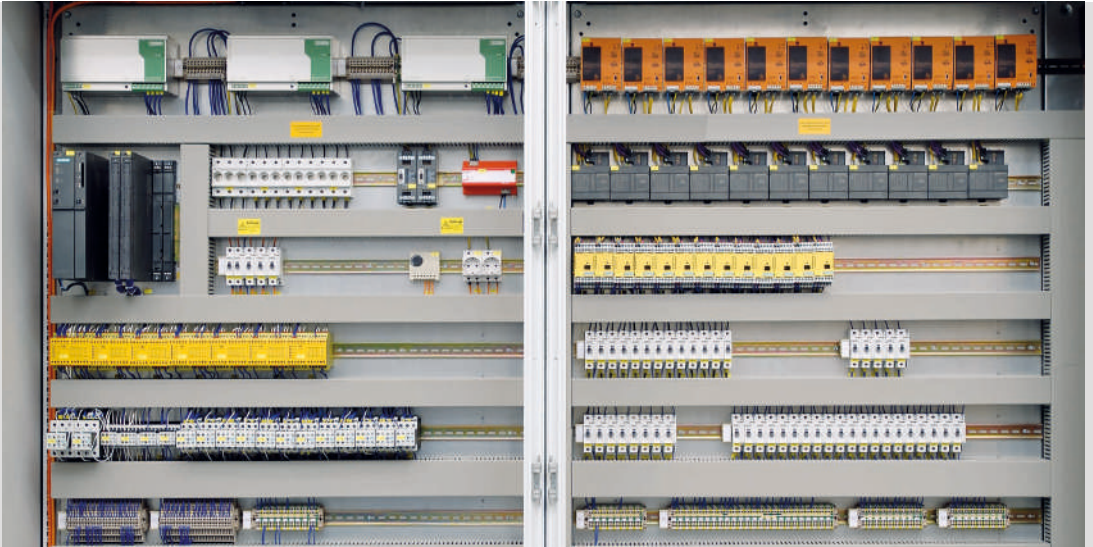

Complete control system with Siemens S7 and bus system



Control cabinet attached on the frame and protective device combination

Application Examples



Control cabinet with operator panel on which minor program changes can be made directly



Door dial with emergency stop button and mobile operator panel

9

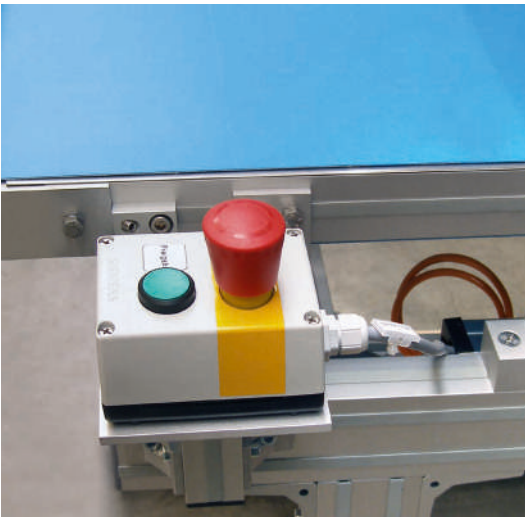

Enable button with emergency stop button



Emergency stop button



Main switch with integrated motor overload switch



Mobile touchscreen with connection box and offset main switch



Compact control device for manual control of transport conveyors and their speed



Standardised operating device

Application Examples

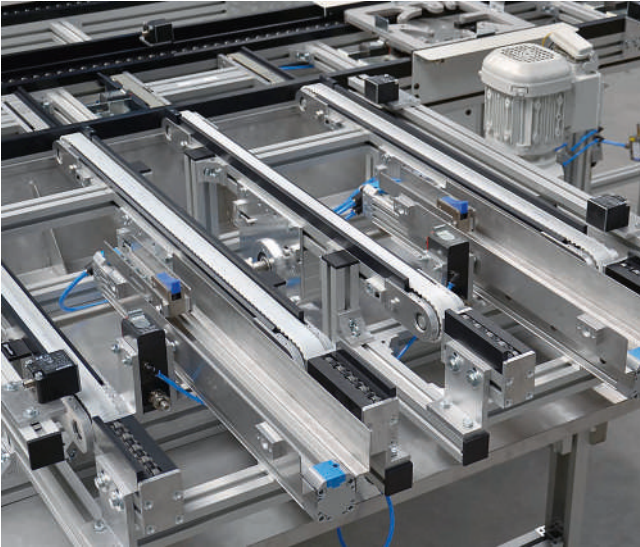

Lift and transfer with component monitoring and end position sensor



Flexible compressed air connection

9



Initiator holder made from aluminium angle bracket

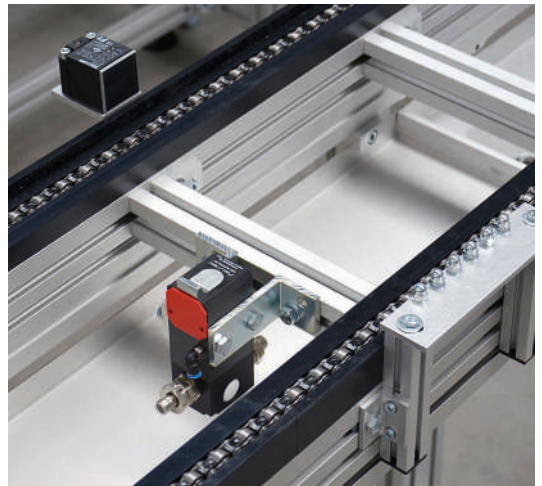

Square sensor and stopper with monitor



Sensors for deceleration and stopping



Initiator holder made from VA steel sheet



Photoelectric sensor with adjustable holder

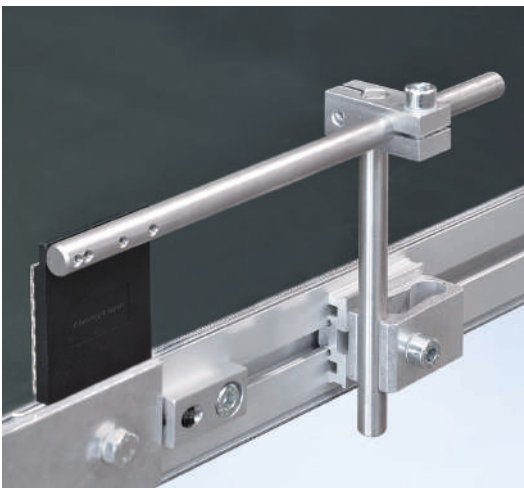

Adjustable reflector holder

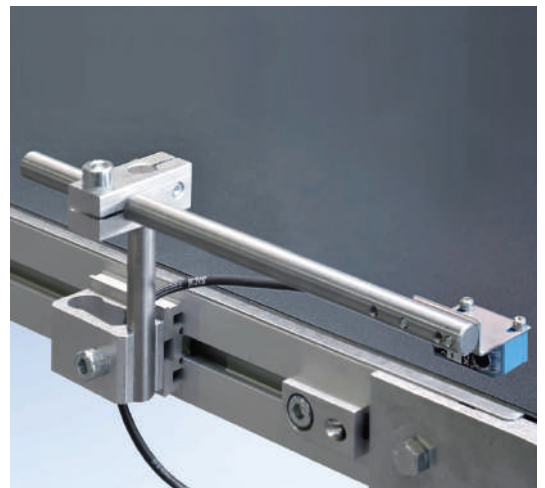

Adjustable holder for photoelectric sensors

Application Examples



Belt conveyor GUF-P 2000 AC with end stop at the end of the conveyor



Modular belt conveyor MBF-P 2040 with end stop at the end of the conveyor

9



Multi-line, adjustable side rail in gantry arrangement



Wiper brush, rotating, mounted at the end of the conveyor



Belt conveyor with dust bag



Belt conveyor with dust bag

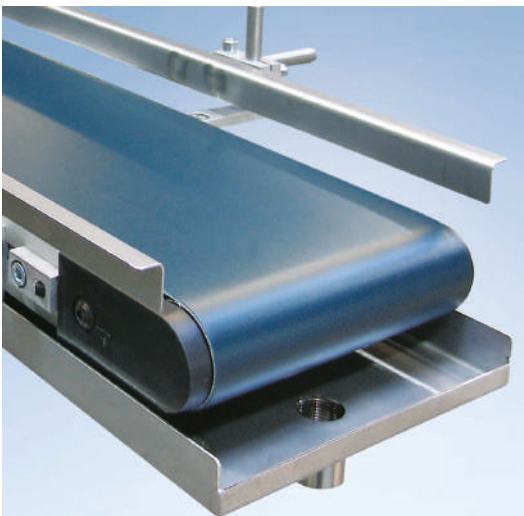

Drip pan with drain port at the beginning of the conveyor

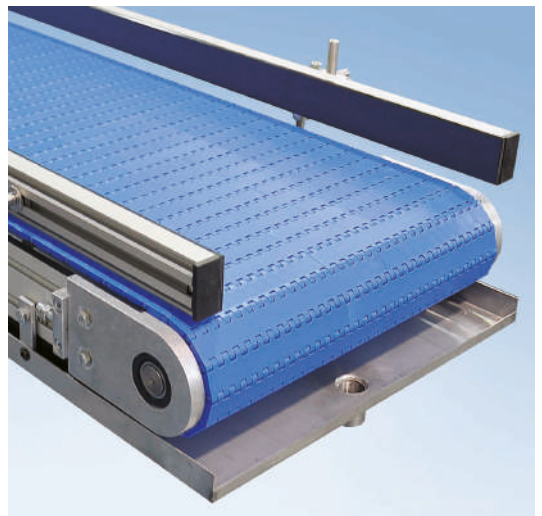

Modular belt conveyor with drip pan

Chapter 10 Information on Linear Technology

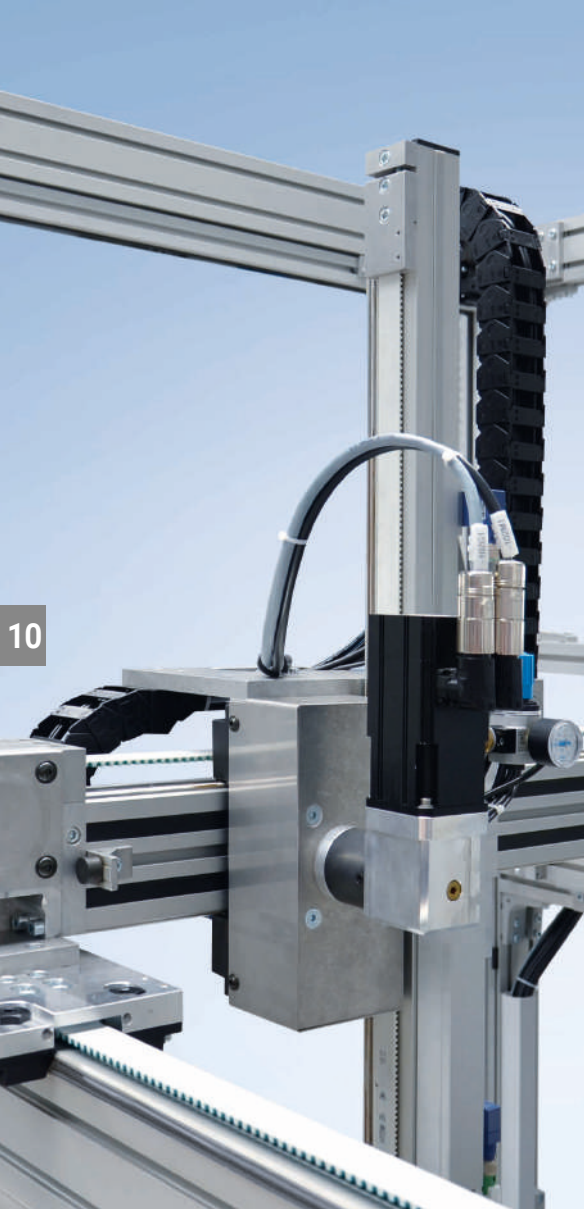

»» Reliable and precise linear motion. ««

mk linear technology is the name for our portfolio of gliding assemblies, track roller assemblies and recirculating ball bearing guides that provide highly precise and reliable linear motion, and that are designed to meet your specific requirements.

Whether you need manual adjusting units or driven linear modules with a timing belt for handling applications, we're happy to advise you on how the optimal linear guides can achieve both exact directional movement and low-friction transport.

mk's linear technology components are fully compatible with mk profile technology. Installing linear guides allows you to quickly and easily implement linear movements into your machine frames. This method reduces the materials required for the solution, since a separate support structure for the linear motion is not required.

Benefits of mk Linear Technology

- The wide range of guides are designed to meet the customer's requirements and provide optimum function
- Compatible with mk profile series to save materials, costs and space: guides can be mounted directly on the existing support structure
- Uncomplicated and rapid setup of linear guides based on the add-on principle
- mk clamping profile ensures precise travel for maximum parallelism of the guide rods
- Highly reliable operation thanks to high-quality materials and tested third-party parts
- mk engineers provide expert advice and assistance in designing your system

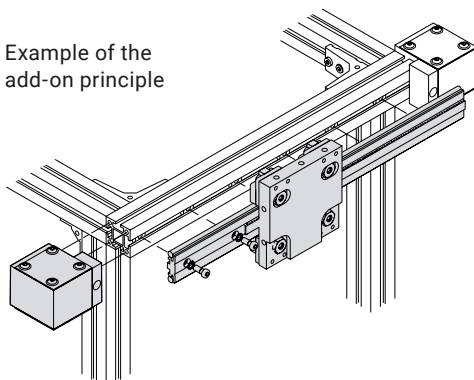

Gliding Assemblies

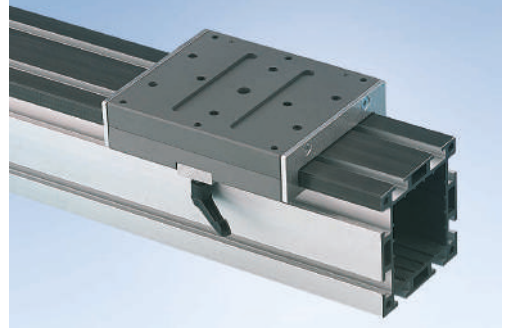

Track Roller Assemblies



Recirculating Ball Bearing Guides

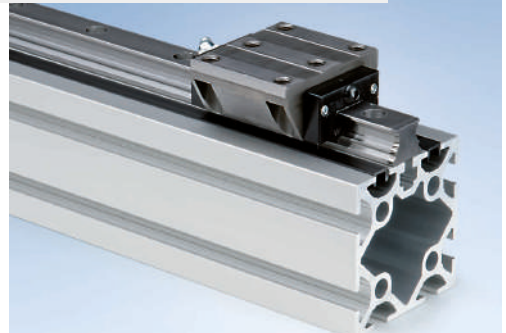

Selecting a Linear Guide

Properties and Benefits of the Different Types of Guide

The following criteria influence the selection of the type of guide to be used for your task and environmental conditions.

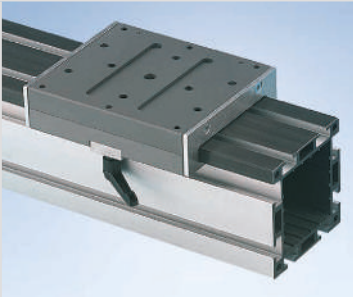

Gliding Assemblies

- For applications that require manual adjustment
- High static load capacity
- Low-maintenance
- Good dry-running characteristics
- Good damping
- Compact design
- Low-noise running

Track Roller Assemblies

- Compensates for relatively large alignment errors
- Well suited for harsh environmental conditions such as dust, chips, etc.
- High acceleration up to $a = 50 \text{ m/s}^2$
- High travel speeds up to $v = 10 \text{ m/s}$
- Low rolling resistance
- mk clamping profile ensures precise travel for maximum parallelism of the guide rods
- Simple and economical guide design also makes it an attractive solution for longer lengths
- Multi-axial, i.e. can be loaded in all directions (forces and torques)
- Eccentrics allow you to adjust the pre-tension

Recirculating Ball Bearing Guides

- High load capacity and high stiffness
- Compact design
- Just one track for different types of roller carriage
- Lightly pre-tensioned (standard), available with play or high pre-tension
- Medium to high acceleration up to $a = 30 \text{ m/s}^2$
- Medium to high speed up to $v = 5 \text{ m/s}$
- Four-row multi-axial recirculating ball bearing guide bears loads in all directions (forces and torques)
- High precision with appropriate contact surfaces

Selection Matrix for Linear Guides

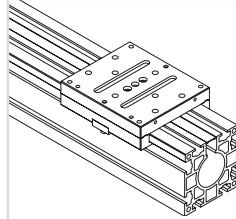

Gliding Assemblies

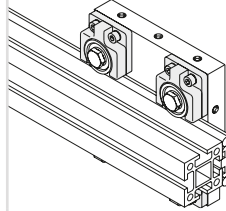

Track Roller Assemblies

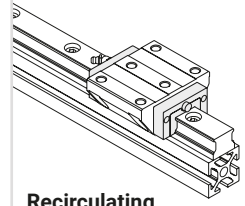

Recirculating
Ball Bearing Guides

Running performance

High

•

•

Low

•

Precision

Very high

•

High

•

Medium

•

Low

Speed

Very high

•

High

•

Medium

Low

•

Load capacity

Very high

•

High

•

Medium

•

Low

Stiffness

Very high

High

•

Medium

•

•

Low

Maintenance

With restrictions

•

Regularly

•

•

Frequently

Chapter 11 Linear Units and Modules



Gliding Assemblies

320

Adjusting Units VST 2015

324

Adjusting Units VST 2011

328

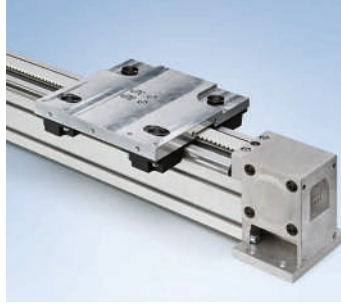

Track Roller Assemblies

332

Features of mk

Track Roller Assemblies

334

Mounting Profile

336

Individual Components

346

Linear Units

352

Linear Modules LZR

374



Recirculating Ball Bearing Guides

384

Recirculating Ball Bearing 25

388

Recirculating Ball Bearing 30

390



Application Examples 392

Gliding Assemblies



» A simple solution
for manual
positioning tasks. «

Our adjusting units (VST) are gliding assemblies in which the different guide components, the profile and the carriages operate on gliding elements rather than being separated by roller bearings. The large contact surfaces and special coating make the gliding assemblies virtually maintenance free. The adjusting units can be supplied in different shapes and combinations as required.

The two basic sizes of adjusting unit use mk 2015 (50x50) and mk 2011 (100x100) aluminium profiles as the profiles. A high-quality coating is mechanically applied to the contact surfaces to ensure good gliding properties and a wear-resistant surface. The standard version of the adjusting units is equipped with ball-bearing-mounted trapezoidal threaded spindles with POM nuts, which are protected from dirt by a stainless steel cover. The nuts, the bearing and the gliding assembly are low maintenance. Custom modifications are available on request, e.g. rust-proof spindles, bronze trapezoidal nuts, ball screws or motorised drives.

The position of the slide carriages can be adjusted with different operating options. When using the adjusting unit with a handwheel, you turn the wheel manually and cannot view the adjustment. When using the adjusting unit with a handwheel and scaling, the adjustment can be viewed on the scaling. In the variant of the adjusting unit with a handwheel and mechanical digital display, the adjustment can be viewed on the digital display.

If requested, the adjusting units can also be operated with a motor. The maximum speed is $v = 1 \text{ m/min}$.

Features of mk Gliding Assemblies

- For applications that require manual adjustment
- High static load capacity
- Low-maintenance
- Good dry-running characteristics
- Good damping
- Compact design
- Low-noise running

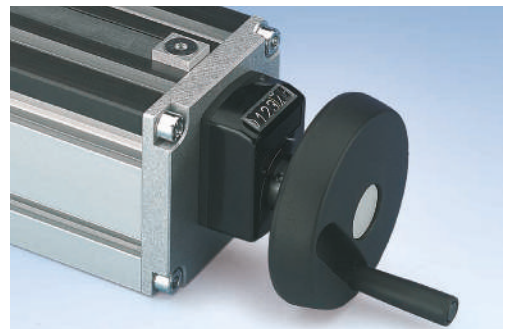
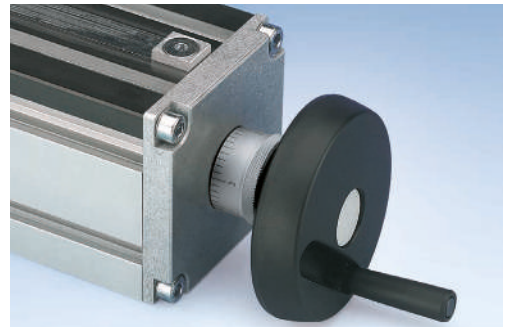
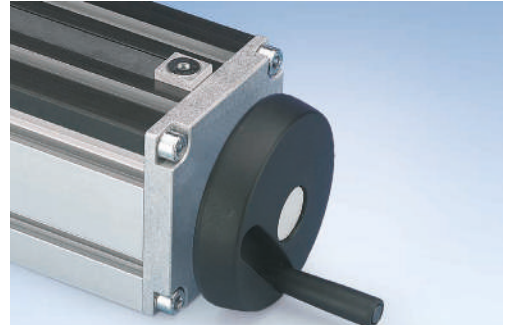

Gliding Assemblies

Designs

Adjusting unit with one slide carriage

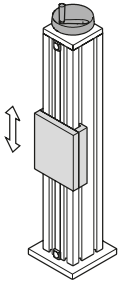

Adjusting unit with two slide carriages (even adjustment)

Independently adjustable lower carriages available as an option

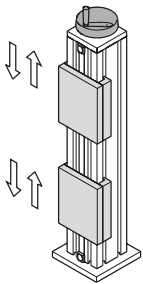

Adjusting unit with two slide carriages (even adjustment)

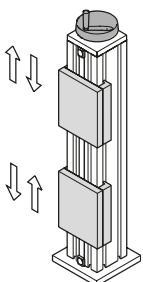

Combinations

A connecting kit lets you combine two adjusting units into one two-axis system.

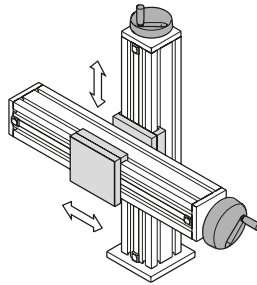

Connecting kit for cross-VST 2015
B46.07.020

Connecting kit for cross-VST 2011
B46.07.021

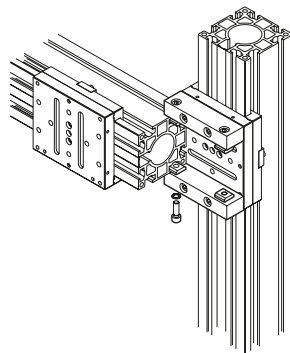

Clamping Levers and Wipers

The felt wiper prevents solid objects from entering between the slide carriages and guide. It can easily be bolted onto the standard slide carriages as an accessory.

In the standard system, the slide carriage is clamped using a clamping plate that is fastened by tightening a screw. This can also be done using an optional clamping lever.

Felt wiper system 2015
B03.00.011

Felt wiper system 2011
B03.00.012

Clamping lever
K110030061

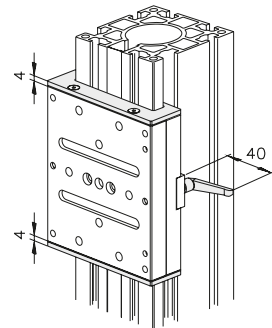

Sample order

Adjusting unit	VST 2011-H		
Item no.	B85.00.020		
Length	L = mm		
Stroke	H = mm		
Operating option	Handwheel	Scaling	Digital*
Base plate	Version A	Version B	
Felt wiper	Yes	No	
Clamping lever	Yes	No	

For the adjusting unit with two slide carriages with even adjustment, please specify whether it uses one or two trapezoidal nuts.

With two trapezoidal nuts, Lx = mm (+_ 2 mm)

*For the digital display, please specify "Front" or "Top" for the reading direction and display of numbers.

Gliding Assemblies

Adjusting Units VST 2015

Mounting profile: mk 2015 (50 x 50 mm)
 Trapezoid-thread spindle: Tr 16 x 4
 Axial spindle load: 500 N
 Standard lengths L: 250 mm, 500 mm,
 750 mm and 1000 mm

The stroke per revolution is 4 mm,
 the minimum stroke length is 10 mm,
 and the maximum length L = 1400 mm.



Handwheel

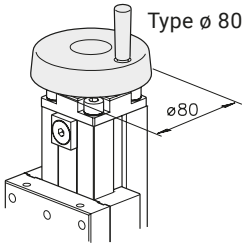

Scaling

System 2015 without scale

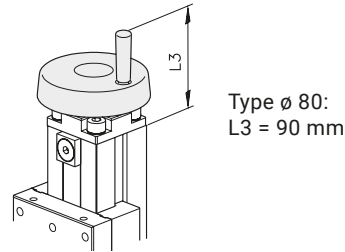

System 2015 with scale

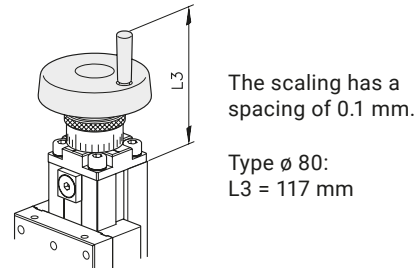

System 2015 with Mechanical Digital Display

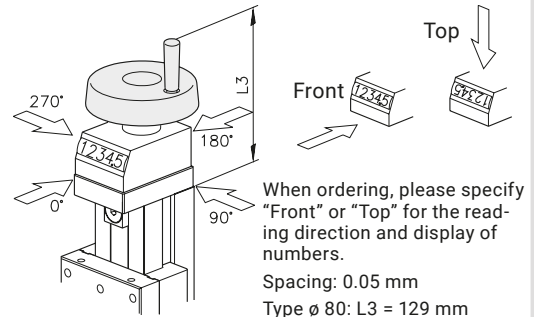

Base Plates

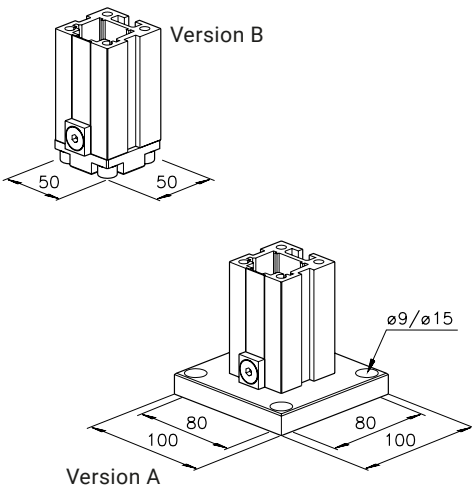

VST 2015 with one Slide Carriage

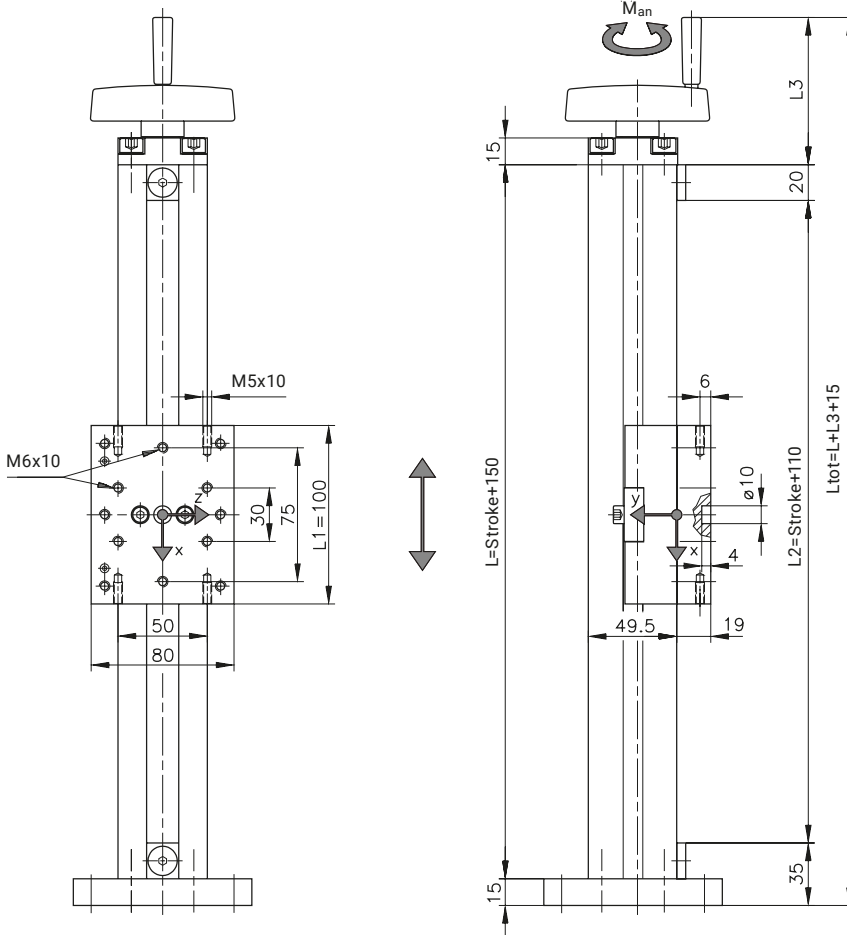

Designs

Design	Without scale	Scale	Digital display
Designation	VST 2015-H	VST 2015-S	VST 2015-D
Type	∅ 80	∅ 80	∅ 80
Item no.	B85.00.015	B85.00.016	B85.00.017

Maximum load specifications for VST 2015

F_y [N]	F_z [N]	M_x [Nm]	M_y [Nm]	M_z [Nm]	M_{Drive} [Nm]	n [min ⁻¹]	v [m/min]
750	750	25	25	25	2.5	250	1

Check max. load specifications for slide carriages, and suitability for use if necessary

Gliding Assemblies

VST 2015 with two Synchronised or Independent Slide Carriages

Options:

VST with two trapezoidal nuts: the two slide carriages are synchronised (see the arrow directions)

VST with one trapezoidal nut: the lower slide carriages can be separately adjusted manually

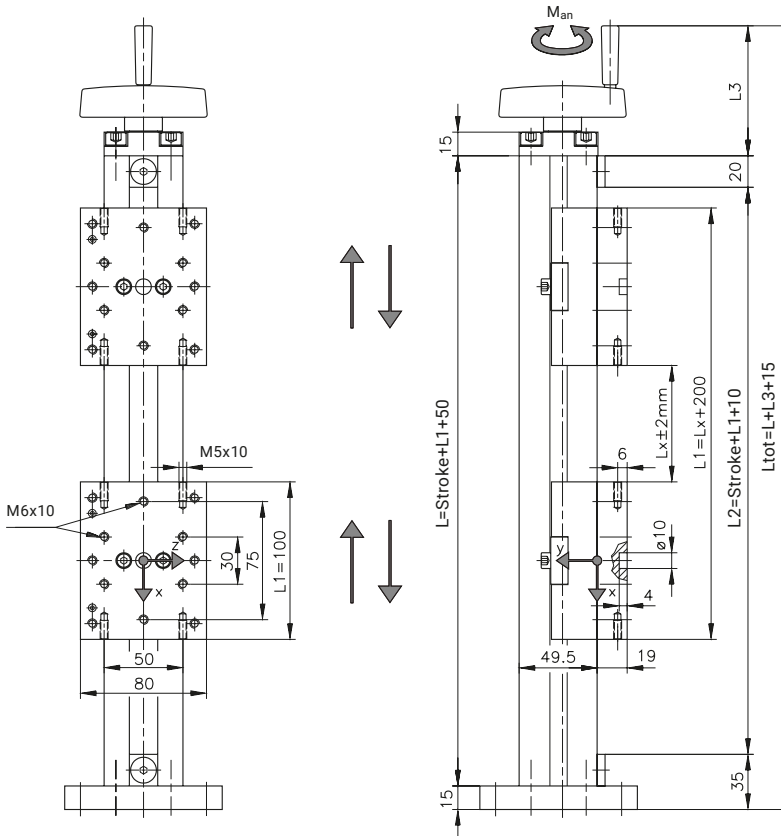

Designs

Design	Without scale	Scale	Digital display
Designation	VST 2015-H-2	VST 2015-S-2	VST 2015-D-2
Type	∅ 80	∅ 80	∅ 80
Item no.	B85.00.115	B85.00.116	B85.00.117

Maximum load specifications for VST 2015

F_y^* [N]	F_z^* [N]	M_x^* [Nm]	M_y^* [Nm]	M_z^* [Nm]	M_{Drive} [Nm]	n [min ⁻¹]	v [m/min]
750	750	25	25	25	2.5	250	1

Check max. load specifications for slide carriages, and suitability for use if necessary. *Max. load specifications per slide carriage.

VST 2015 with Two Synchronised Slide Carriages

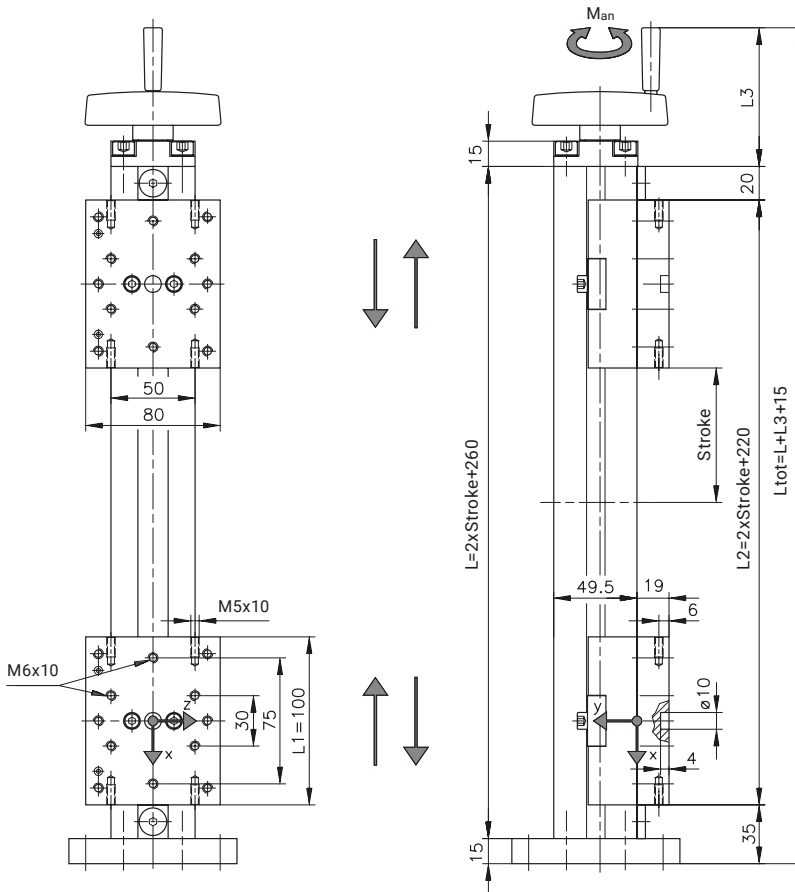

Designs

Design	Without scale	Scale	Digital display
Designation	VST 2015-H-G	VST 2015-S-G	VST 2015-D-G
Type	ø 80	ø 80	ø 80
Item no.	B85.00.215	B85.00.216	B85.00.217

Maximum load specifications for VST 2015

F _y *	F _z *	M _x *	M _y *	M _z *	M _{Drive}	n	v
[N]	[N]	[Nm]	[Nm]	[Nm]	[Nm]	[min ⁻¹]	[m/min]
750	750	25	25	25	2.5	250	1

Check max. load specifications for slide carriages, and suitability for use if necessary. *Max. load specifications per slide carriage.



Gliding Assemblies

Adjusting Units VST 2011

Mounting profile: mk 2011 (100 x 100 mm)
 Trapezoid-thread spindle: Tr 20 x 4
 Axial spindle load: 1000 N
 Standard lengths L: 250 mm, 500 mm,
 750 mm and 1000 mm

The stroke per revolution is 4 mm,
 the minimum stroke length is 10 mm,
 and the maximum length L = 1400 mm.

Handwheel

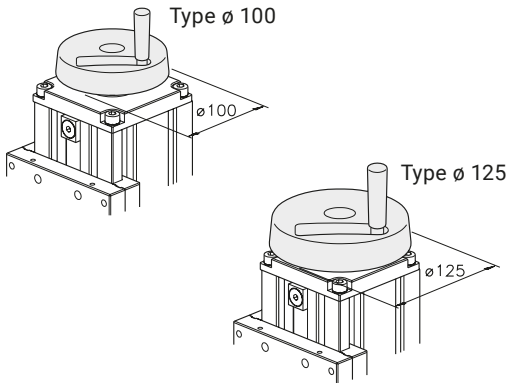

Scaling

System 2011 without scale

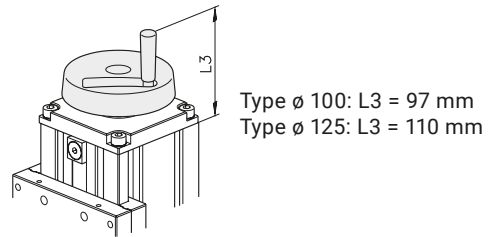

System 2011 with scale

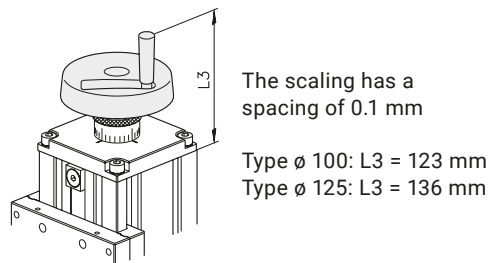

Base Plates

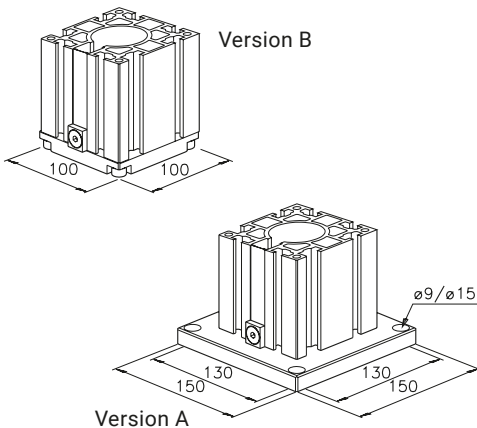

System 2011 with Mechanical Digital Display

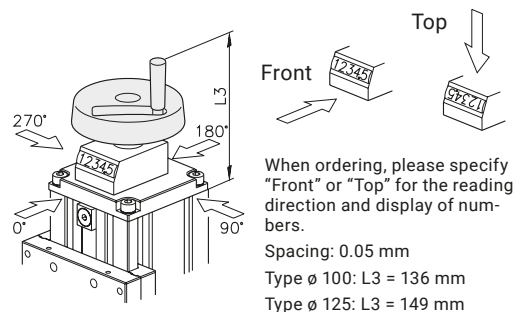

VST 2011 with one Slide Carriage

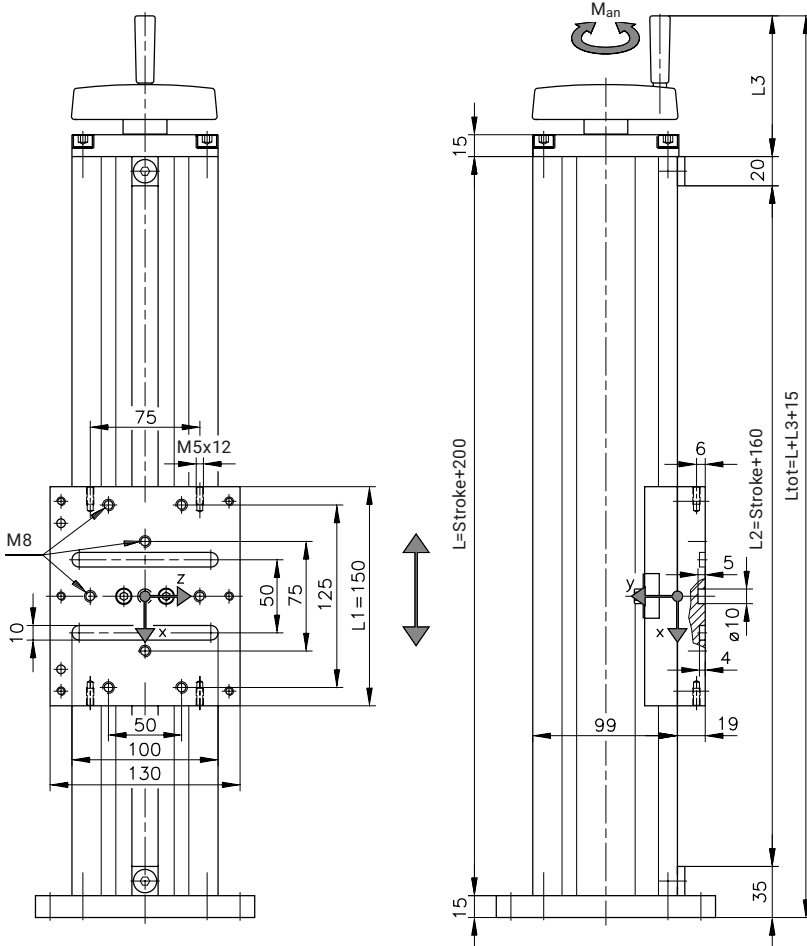

Designs

Design	Without scale		Scale		Digital display	
Designation	VST 2011-H	VST 2011-H	VST 2011-S	VST 2011-S	VST 2011-D	VST 2011-D
Type	∅ 100	∅ 125	∅ 100	∅ 125	∅ 100	∅ 125
Item no.	B85.00.020	B85.00.025	B85.00.021	B85.00.026	B85.00.022	B85.00.027

Maximum load specifications for VST 2011

F _y [N]	F _z [N]	M _x [Nm]	M _y [Nm]	M _z [Nm]	M _{Drive} [Nm]	n [min ⁻¹]	v [m/min]
2000	2000	75	100	100	6	250	1

Check max. load specifications for slide carriages, and suitability for use if necessary.

Gliding Assemblies

VST 2011 with Two Synchronised or Independent Slide Carriages

Options:

VST with two trapezoidal nuts: the two slide carriages are synchronised (see the arrow directions)

VST with one trapezoidal nut: the lower slide carriages can be separately adjusted manually

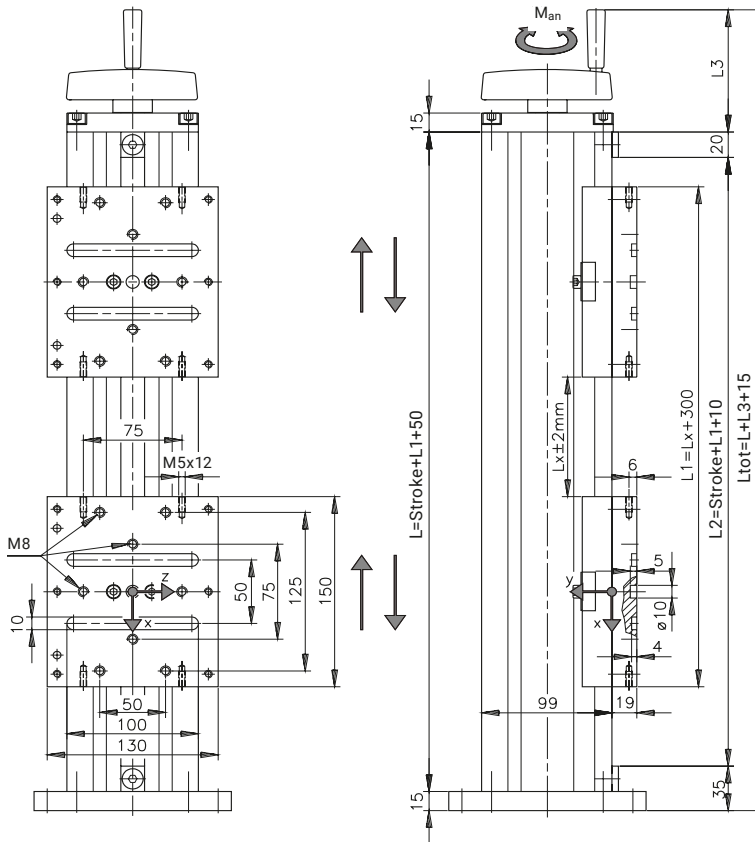

Designs

Design	Without scale		Scale		Digital display	
Designation	VST 2011-H-2	VST 2011-H-2	VST 2011-S-2	VST 2011-S-2	VST 2011-D-2	VST 2011-D-2
Type	∅ 100	∅ 125	∅ 100	∅ 125	∅ 100	∅ 125
Item no.	B85.00.120	B85.00.125	B85.00.121	B85.00.126	B85.00.122	B85.00.127

Maximum load specifications for VST 2011

F _y *	F _z *	M _x *	M _y *	M _z *	M _{Drive}	n	v
[N]	[N]	[Nm]	[Nm]	[Nm]	[Nm]	[min ⁻¹]	[m/min]
2000	2000	75	100	100	6	250	1

Check max. load specifications for slide carriages, and suitability for use if necessary. *Max. load specifications per slide carriage.

VST 2011 with Two Synchronised Slide Carriages

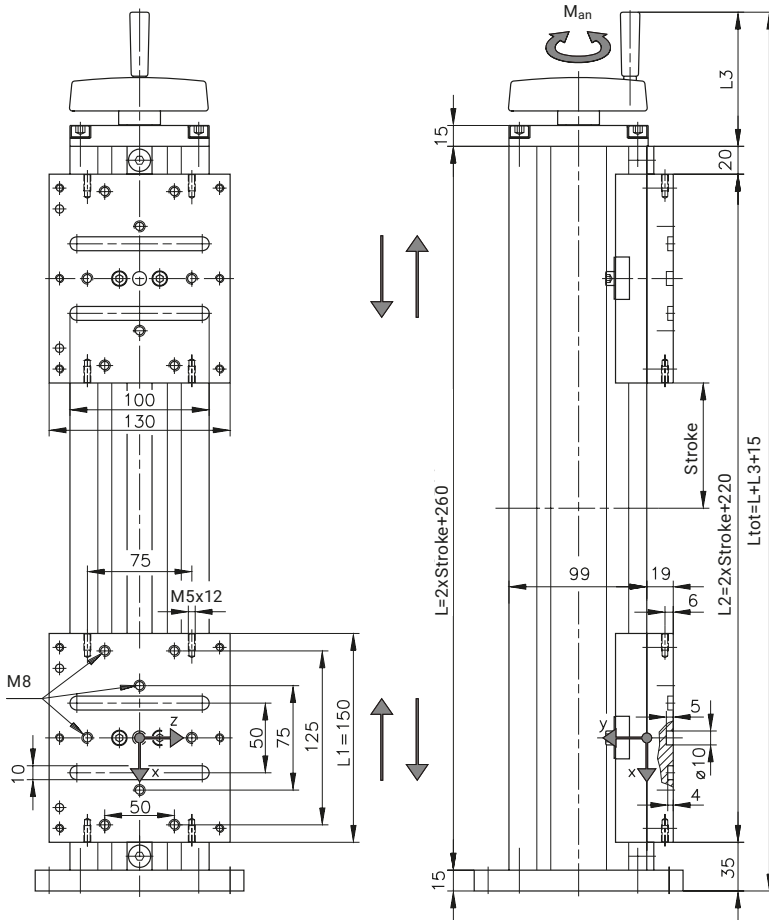

11

Designs

Design	Without scale		Scale		Digital display	
Designation	VST 2011-H-G	VST 2011-H-G	VST 2011-S-G	VST 2011-S-G	VST 2011-D-G	VST 2011-D-G
Type	$\varnothing 100$	$\varnothing 125$	$\varnothing 100$	$\varnothing 125$	$\varnothing 100$	$\varnothing 125$
Item no.	B85.00.220	B85.00.225	B85.00.221	B85.00.226	B85.00.222	B85.00.227

Maximum load specifications for VST 2011

F_y^* [N]	F_z^* [N]	M_x^* [Nm]	M_y^* [Nm]	M_z^* [Nm]	M_{Drive} [Nm]	n [min ⁻¹]	v [m/min]
2000	2000	75	100	100	6	250	1

Check max. load specifications for slide carriages, and suitability for use if necessary. *Max. load specifications per slide carriage.

Track Roller Assemblies



» Linear modules based on track roller assemblies. «

Because of their rigid structure, track roller assemblies offer high accelerations and speeds over a long service life and allow for fast positioning with high repeatability.

They are excellently suited for both single-axis applications and use as multi-axis systems. Linear systems constructed from these modules can meet even the most demanding technical and financial requirements.

Track roller assemblies consist of a linear guide with a matching roller carriage. The guide is built from a standard mk profile that acts as the mounting profile and guide rods that are mounted to the mounting profile with a clamping profile. The roller carriage consists of a support plate and guide rollers, which can be custom-configured to meet your specific requirements. The guide rollers have eccentric bearings to prevent play in the guide. The series and the dimensions chosen for the mounting profile are key factors that determine the linear module design.

Linear Module with Timing Belt (LZR)

Linear modules based on track roller assemblies are usually equipped with a high-powered drive connected via a timing belt. The components of the timing belt drive responsible for transferring the power, such as the deflection bearings and the connectors, are mounted on the mounting profile at the head end. The motor can be connected directly via the shaft end or indirectly on request. LZRs are the preferred solutions for implementing handling systems with an X-Y-Z axis.

Benefits of mk Track Roller Assemblies

- Compensates for relatively large alignment errors
- Well suited for harsh environmental conditions such as dust, chips, etc.
- High acceleration up to $a = 50 \text{ m/s}^2$
- High travel speeds up to $v = 10 \text{ m/s}$
- Low rolling resistance
- mk clamping profile ensures precise travel for maximum parallelism of the guide rods
- Simple and economical guide design also makes it an attractive solution for longer lengths
- Multi-axial, i.e. can be loaded in all directions (forces and torques)
- Eccentrics allow you to adjust the pre-tension

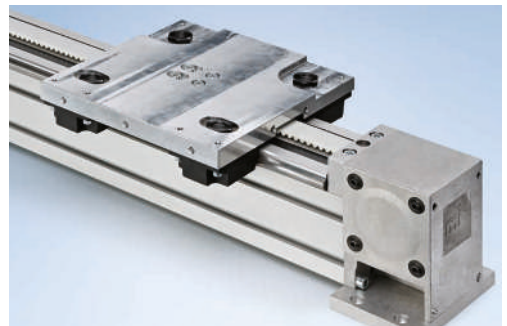
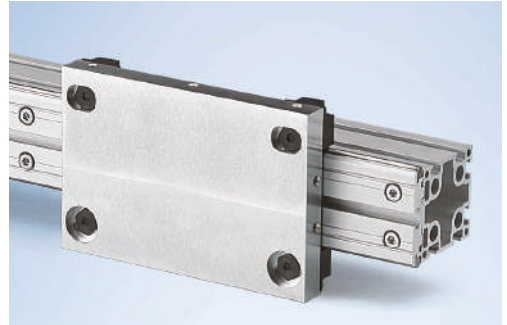

Features of mk Track Roller Assemblies

Mounting Profiles

The linear units and modules shown in the catalogue are based on mk's own profile system. Note the series and dimensions of the mounting profiles.

Mounting profiles can also be used in combination with foamed combined profiles to construct gantries with span widths of up to 10 metres.

The suitability for use (deformation) and strength calculation are decisive factors for the mounting profile. A deformation of 1 mm/m is permitted for the function of the linear guide. The deformation and strength are calculated based on the basic rules of technical mechanics.

Examples of mk Mounting Profiles

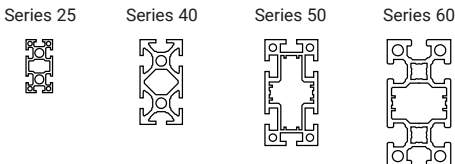

Examples of Foamed Combined Profiles

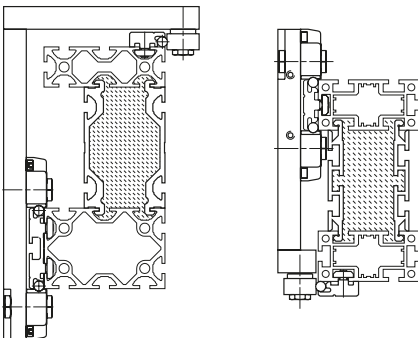

Series 25 Profile Guides

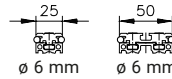

Series 40 Profile Guides

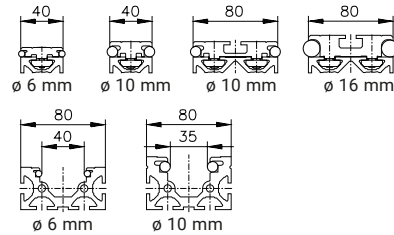

Series 50 Profile Guides

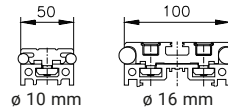

Series 60 Profile Guides

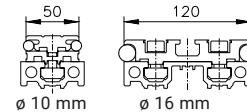

Adapter Profiles

Adapter profiles enable a wide variety of possible combinations. They are used to create the necessary distance for the roller carriage in cases where the dimensions of the mounting profile exceed the clamping profile. Some profiles can also be adapted between different profile series.

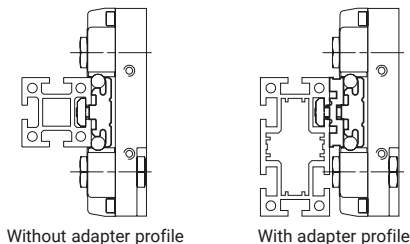

Stock lengths

The maximum length of linear units is 6000 mm. It can be exceeded by mounting multiple mounting profiles with clamping profiles and guide rods set on joins that are mounted staggered with each other.

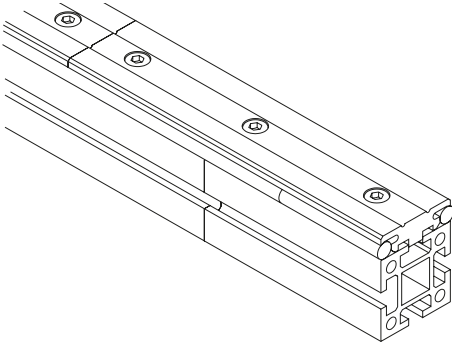

Guides

The load capacity of the guide is based primarily on the diameter of the guide rod and on the corresponding guide roller. mk offers four guide rod diameters. The guide rods (ground h6) are made from the material Cf 53 as standard, but are also available as options made from X46 Cr13 with corrosion resistance or galvanised Cf 53 with corrosion protection.

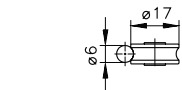

Guide rod 6
0.22 kg/m

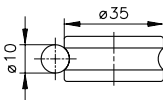

Guide rod 10
0.62 kg/m

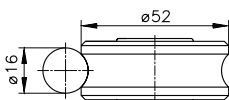

Guide rod 16
1.58 kg/m

Roller Carriage

The mk roller carriage comes with four rollers as standard, but is also available as an option with three or two rollers on request.

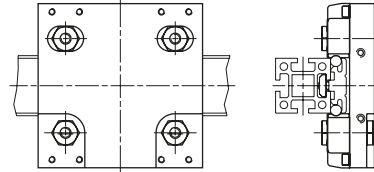

Example of external track rollers

Example of internal track rollers

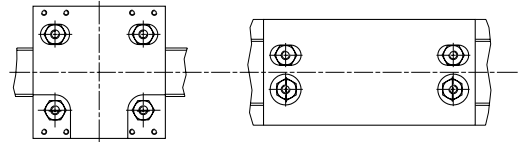

Designs

The mk roller carriage is available with the standard design (see above) and two additional designs.

Cross-carriage

Double-roller carriage

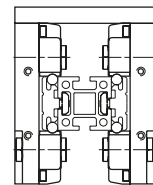
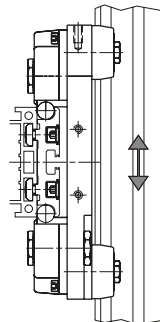

Features of mk Track Roller Assemblies

Design of the Track Rollers

The indicated static load carrying capacities can be used as a guideline for the preliminary selection of track rollers. These values are the maximum allowable unit loads and include a static safety factor $s_0 = 4$ in relation to the plastic deformation of the roller bearings within the steel track roller. For stainless steel components, these values must be reduced by 30%.

The load values shown for the axial load (F_y) and radial load (F_z) are for moment-free loads. The allowable moments are the result of opposing offset loads.

Combined loads must be verified separately. A combined load is a single point load which, with a 50 mm offset for example, also introduces a moment. Careful consideration must be given to combined loads which cause torsion.

When arranging track rollers, it is important that the track rollers only transfer compressive loads in the radial direction. The centric track rollers are especially suitable for handling radial loads, especially in the F_z direction. The centric track rollers are prevented from twisting by using a steel bushing.

Application Notes

Care must be taken to ensure that the track rollers are installed in an unloaded condition. In most cases, readjustment of the eccentric track rollers under load

causes premature wear. For "normal" applications (up to $a = 3 \text{ m/s}^2$), the track rollers should be set so that they rotate as they travel along the track but you can still prevent this rotation by placing your thumb and index finger on the circumference of the roller.

For applications requiring a speed of over $a = 3 \text{ m/s}^2$, the track rollers require further pre-tensioning, and you can then no longer manually prevent the rollers from rotating. As an additional safety measure, we recommend securing the eccentric bushings with adhesive to prevent them from slipping. To prevent corrosion and increased abrasion, sufficient lubrication must also be used.

Calculations

When confirming the suitability of particular track rollers, a distinction must be made between static and the dynamic loading. Static loads are loads that are transferred at the contact point between the rod and the track roller while the roller is not rotating. That is to say that dynamic loads, or loads along other axes, must also be considered.

It is helpful to first confirm the static and then the dynamic load calculations. The allowable static axial and radial track roller loads and the static and dynamic safety factors of the most highly loaded rollers must be confirmed. The maximum track roller loads are technically considered mechanical contact loads (supported loads).

The static safety factor and dynamic safety factor are derived from the relationship between the allowable load capacity C_w and the available equivalent load P .

Recommended Guidelines

Up to $v = 3 \text{ m/s}$ and $a = 3 \text{ m/s}^2$, full load capacity of the track rollers with $s_0 \geq 4$ and $2 < s_D \leq 5$.

For high dynamic loads with $a > 10 \text{ m/s}^2$ and speeds of up to $v = 10 \text{ m/s}$, the load values must be reduced.

Technical Specifications for Track Roller Assemblies

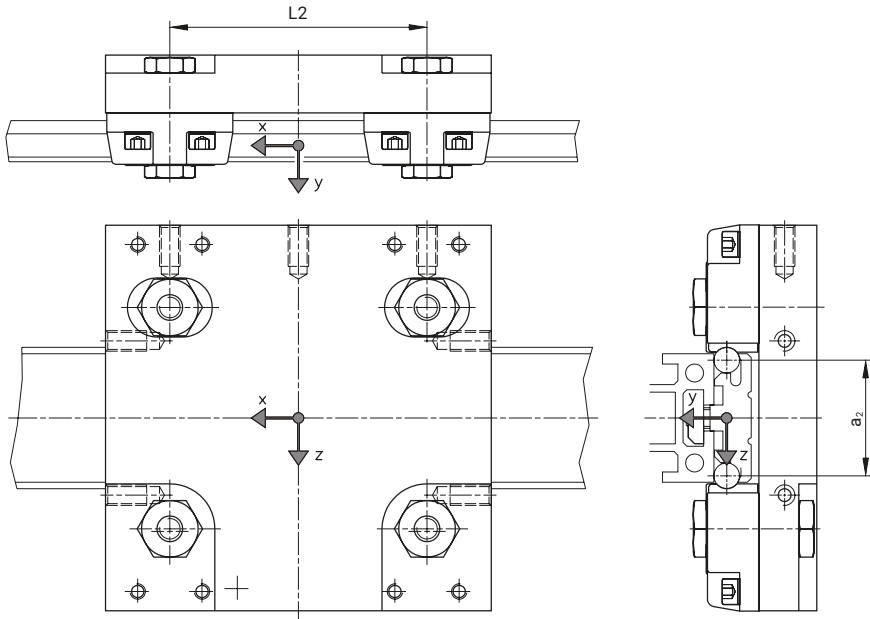

Static safety factor:

$$s_o = \frac{C_{ow}}{P_o} \geq 4 = s_o \text{ recomm.}$$

Dynamic safety factor:

$$s_D = \frac{C_w}{P} \geq 5 = s_D \text{ recomm.}$$

Nominal service life:

$$L_h = \left(\frac{C_w}{P}\right)^3 [10^5 \text{ m}]$$

Equivalent loads

– Static:

$$P_o = x_o \cdot F_{ro} + y_o \cdot F_{ao} \text{ [N]}$$

– Dynamic:

$$P = x \cdot F_r + y \cdot F_a \text{ [N]}$$

Factors from the table

- Static: roller stationary
- Dynamic: roller rotating

Track roller loads

– Radial:

$$F_{r(o)} = \pm \frac{F_{z(o)}}{2} \pm \frac{M_{y(o)}}{L_2} \text{ [N]}$$

– Axial:

$$F_{a(o)} = \pm \frac{F_{y(o)}}{4} \pm \frac{M_{x(o)}}{2 \cdot a_2} \pm \frac{M_{z(o)}}{2 \cdot L_2} \text{ [N]}$$

Most highly loaded roll (that is, with the largest value respectively)

Load specifications

Item no.	Designation Guide with	Rod ø	F _{ro-max} [N]	F _{ao-max} [N]	F _{r(0)} ≥ F _{a(0)}				F _{r(0)} < F _{a(0)}				C _{ow} [N]	C _w [N] based on 10 ⁵ m
					x _o	y _o	x	y	x _o	y _o	x	y		
K101100003	LR 6	6	175	60	1.2	3.6	1.0	3.1	0.9	3.6	0.5	3.9	890	1270
K101100001	LR 10	10	1000	300	1.2	4.0	1.0	3.4	0.9	4.0	0.5	4.3	5100	8500
K101100002	LR 16	16	2000	500	1.2	4.8	1.0	3.9	1.0	5.0	0.5	4.8	9500	16800
K101100006	LR 20	20	3250	825	1.2	4.9	1.0	4.0	1.1	5.0	0.5	4.9	16600	29500

Series 25 Mounting Profiles

Selection Based on Load and Length

Example

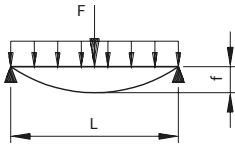

$$F = 100 \text{ N}$$

$$L = 1000 \text{ mm}$$

=> suitable profile mk 2025.02-flat

$$\text{with } \frac{f}{L} \leq \frac{1}{1000}$$

With point load at centre and profile weight for the case: $\frac{f}{L} = \frac{1}{1000}$

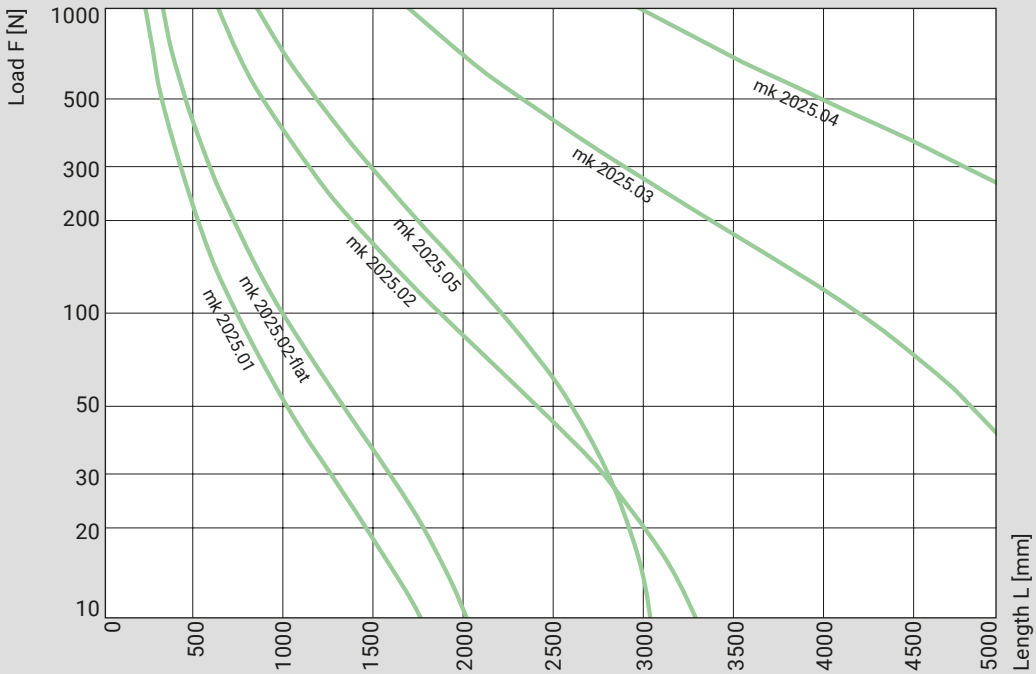

Calculating the Deflection

Use our online tool at www.mk-group.com/en/deflection

$$\sigma_b = \frac{M_{bmax}}{W_{x,y}}$$

$$S = \frac{R_{p0.2}}{\sigma_b}$$

$$R_{p0.2} = 200 \text{ N/mm}^2 \text{ (AlMgSi 0.5 F25)}$$

$$R_{p0.2} = 215 \text{ N/mm}^2 \text{ (AlMgSi 0.7 F27)}$$

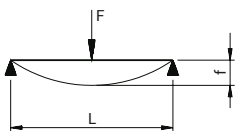

$$M_{bmax} = \frac{F \cdot L}{4}$$



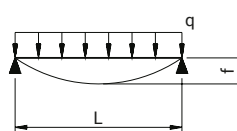

$$f = \frac{F \cdot L^3}{48 \cdot E \cdot I_{x,y}}$$



$$M_{bmax} = \frac{q \cdot L^2}{8}$$

$$f = \frac{5}{384} \cdot \frac{q \cdot L^4}{E \cdot I_{x,y}}$$

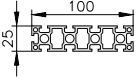
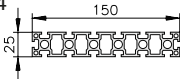
Mounting Profiles with Properties

	Area A [mm ²]	Mass m [kg/m]	Moments of inertia		Section moduli	
			I _x [cm ⁴]	I _y [cm ⁴]	W _x [cm ³]	W _y [cm ³]
Series 25 Profiles						
mk 2025.01 25.01. 	279	0.75	1.73	1.73	1.38	1.38
mk 2025.02 25.02. 	501	1.35	12.20	3.30	4.87	2.64
mk 2025.03 25.03. 	945	2.55	87.00	6.44	17.40	5.15
mk 2025.04 25.04. 	1390	3.75	280.00	9.58	37.30	7.66
mk 2025.05 25.05. 	816	2.21	22.30	22.30	8.90	8.90

Series 40 Mounting Profiles

Selection Based on Load and Length

Example

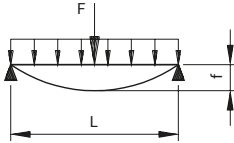

$F = 300 \text{ N}$
 $L = 1500 \text{ mm}$
 \Rightarrow suitable profile mk 2040.02-flat
 with $\frac{f}{L} \leq \frac{1}{1000}$

With point load at centre and profile weight for the case: $\frac{f}{L} = \frac{1}{1000}$

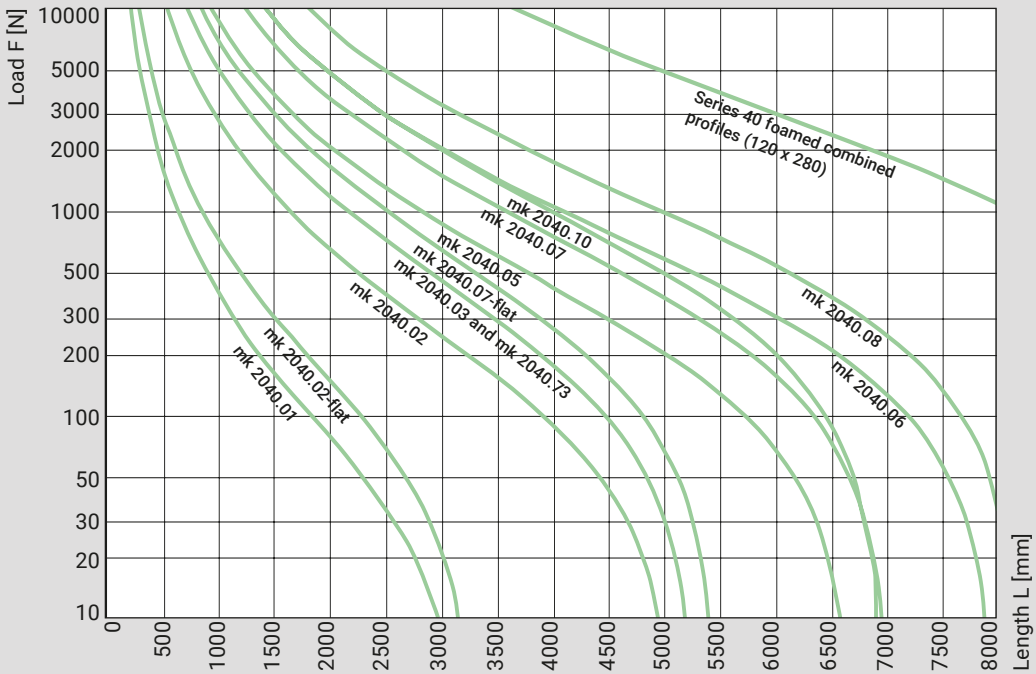

Calculating the Deflection

Use our online tool at www.mk-group.com/en/deflection

$$\sigma_b = \frac{M_{bmax}}{W_{x,y}}$$

$$S = \frac{R_{p0.2}}{\sigma_b}$$

$R_{p0.2} = 200 \text{ N/mm}^2$ (AlMgSi 0.5 F25)

$R_{p0.2} = 215 \text{ N/mm}^2$ (AlMgSi 0.7 F27)

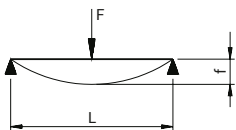

$$M_{bmax} = \frac{F \cdot L}{4}$$

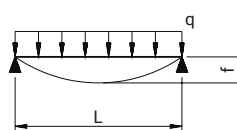

$$f = \frac{F \cdot L^3}{48 \cdot E \cdot I_{x,y}}$$



$$M_{bmax} = \frac{q \cdot L^2}{8}$$

$$f = \frac{5}{384} \cdot \frac{q \cdot L^4}{E \cdot I_{x,y}}$$

Mounting Profiles with Properties

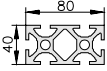
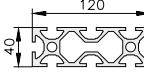
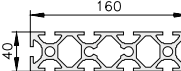
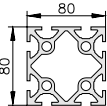
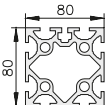
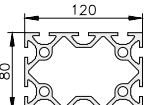
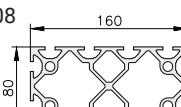
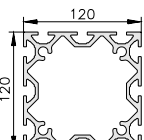
	Area A [mm ²]	Mass m [kg/m]	Moments of inertia		Section moduli	
			I _x [cm ⁴]	I _y [cm ⁴]	W _x [cm ³]	W _y [cm ³]
Series 40 Profiles						
mk 2040.01 54.01. 	742	2.00	12.10	12.10	6.06	6.06
mk 2040.02 54.02. 	1340	3.62	83.30	22.60	20.80	11.30
mk 2040.05 54.05. 	1740	4.69	257.00	31.60	43.70	15.80
mk 2040.06 54.06. 	2320	6.26	576.00	41.40	72.00	20.70
mk 2040.03 54.03. 	2060	5.57	150.00	150.00	37.40	37.40
mk 2040.73 54.73. 	2110	5.72	150.00	150.00	37.10	37.40
mk 2040.07 54.07. 	2580	6.96	441.00	208.00	73.40	52.10
mk 2040.08 54.08. 	3500	9.46	949.00	272.00	119.00	68.00
mk 2040.10 54.10. 	3060	8.26	585.00	585.00	97.50	97.50

Series 50 Mounting Profiles

Selection Based on Load and Length

Example

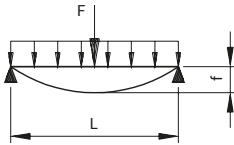

$$F = 400 \text{ N}$$

$$L = 2000 \text{ mm}$$

=> suitable profile mk 2004-flat

$$\text{with } \frac{f}{L} \leq \frac{1}{1000}$$

With point load at centre and profile weight for the case: $\frac{f}{L} = \frac{1}{1000}$

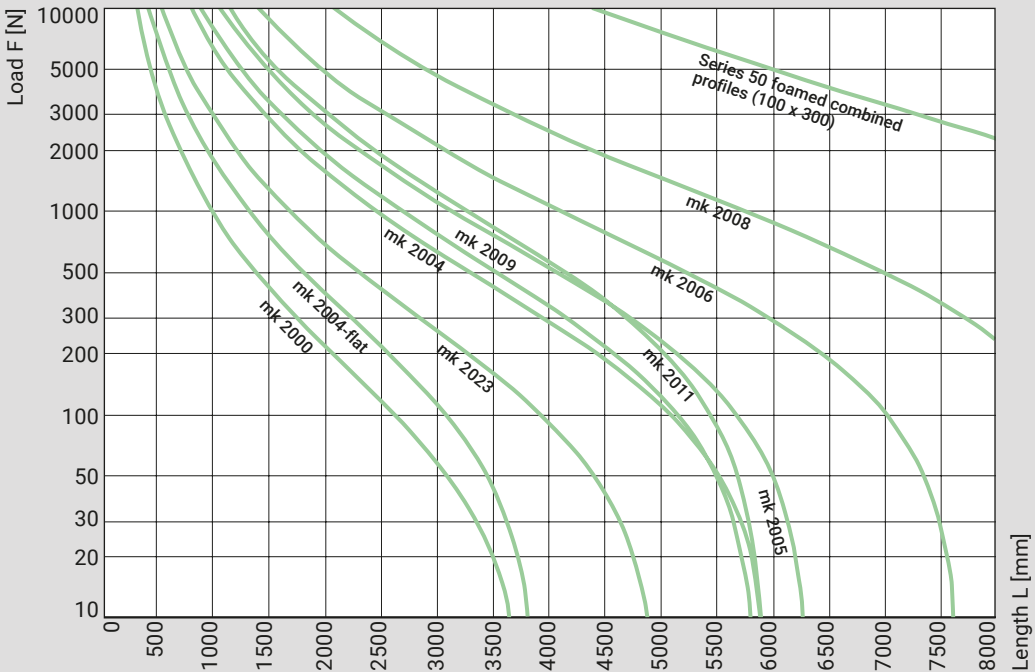

Calculating the Deflection

Use our online tool at www.mk-group.com/en/deflection

$$\sigma_b = \frac{M_{bmax}}{W_{x,y}}$$

$$S = \frac{R_{p0,2}}{\sigma_b}$$

$$R_{p0,2} = 200 \text{ N/mm}^2 \text{ (AlMgSi 0.5 F25)}$$

$$R_{p0,2} = 215 \text{ N/mm}^2 \text{ (AlMgSi 0.7 F27)}$$

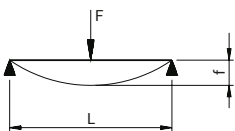

$$M_{bmax} = \frac{F \cdot L}{4}$$

$$f = \frac{F \cdot L^3}{48 \cdot E \cdot I_{x,y}}$$

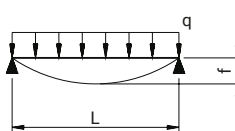

$$M_{bmax} = \frac{q \cdot L^2}{8}$$

$$f = \frac{5}{384} \cdot \frac{q \cdot L^4}{E \cdot I_{x,y}}$$

Mounting Profiles with Properties

		Area A [mm ²]	Mass m [kg/m]	Moments of inertia		Section moduli	
				I _x [cm ⁴]	I _y [cm ⁴]	W _x [cm ³]	W _y [cm ³]
Series 50 Profiles							
mk 2000 51.00.		1080	2.85	29.90	29.90	12.00	12.00
mk 2023 51.23.		1400	3.78	89.3	39.6	23.8	15.8
mk 2004 51.04.		1810	4.87	200.00	55.40	40.00	22.10
mk 2006 51.06.		2600	7.00	597.00	80.50	79.70	32.10
mk 2008 51.08.		3370	9.09	1300.00	107.00	130.00	42.70
mk 2005 (light duty) 51.05.		2650	7.00	335.00	335.00	67.00	67.00
mk 2011 51.11.		3670	9.70	383.00	383.00	76.70	76.70
mk 2009 51.09.		2320	6.27	239	239	42	42

Series 60 Mounting Profiles

Selection Based on Load and Length

Example

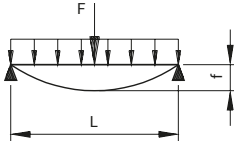

$F = 800 \text{ N}$
 $L = 4500 \text{ mm}$
 \Rightarrow suitable profile mk 2060.05
 with $\frac{f}{L} \leq \frac{1}{1000}$

With point load at centre and profile weight for the case: $\frac{f}{L} = \frac{1}{1000}$

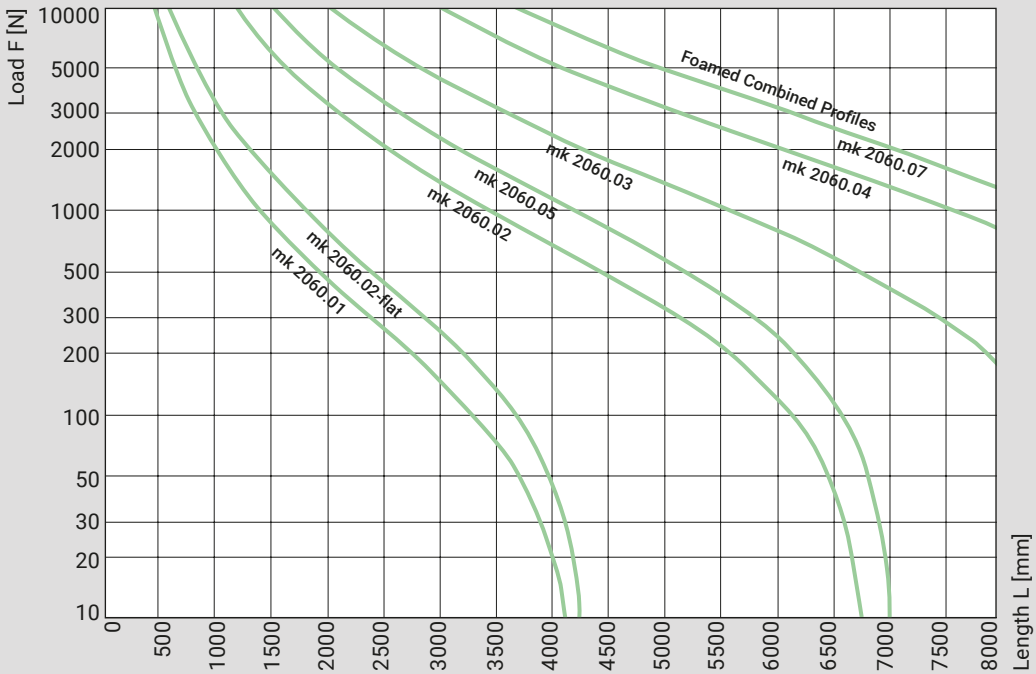

Calculating the Deflection

Use our online tool at www.mk-group.com/en/deflection

$$\sigma_b = \frac{M_{b\max}}{W_{x,y}}$$

$$S = \frac{R_{p0.2}}{\sigma_b}$$

$R_{p0.2} = 200 \text{ N/mm}^2$ (AlMgSi 0.5 F25)

$R_{p0.2} = 215 \text{ N/mm}^2$ (AlMgSi 0.7 F27)

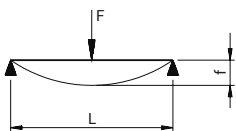

$$M_{b\max} = \frac{F \cdot L}{4}$$

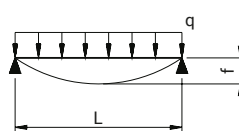

$$f = \frac{F \cdot L^3}{48 \cdot E \cdot I_{x,y}}$$



$$M_{b\max} = \frac{q \cdot L^2}{8}$$

$$f = \frac{5}{384} \cdot \frac{q \cdot L^4}{E \cdot I_{x,y}}$$

Mounting Profiles with Properties

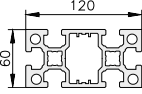
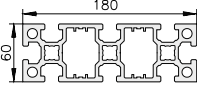
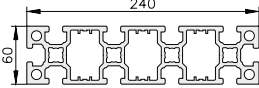
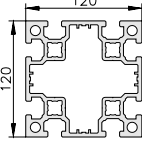
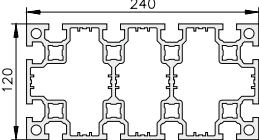
	Area A [mm ²]	Mass m [kg/m]	Moments of inertia		Section moduli	
			I _x [cm ⁴]	I _y [cm ⁴]	W _x [cm ³]	W _y [cm ³]
Series 60 Profiles						
mk 2060.01 60.01. 	1600	4.31	60.20	60.20	20.00	20.00
mk 2060.02 60.02. 	2580	6.95	404.00	103.00	67.30	34.50
mk 2060.03 60.03. 	3540	9.57	1210.00	147.00	134.00	48.90
mk 2060.04 60.04. 	4520	12.20	2660.00	190.00	221.00	63.30
mk 2060.05 60.05. 	3800	10.30	660.00	660.00	110.00	110.00
mk 2060.07 60.07. 	6700	18.10	4090.00	1180.00	340.00	169.00

Individual Components

Clamping Profiles for Series 25

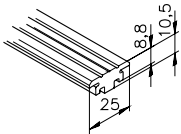

Profile mk 2038.20

0.44 kg/m

Stock length	38.20.6100
Cut	38.20.

Used for \varnothing 6 mm guide rod

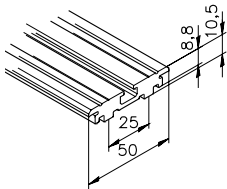

Profile mk 2038.21

0.88 kg/m

Stock length	38.21.6100
Cut	38.21.

Used for \varnothing 6 mm guide rod

Clamping Profiles for Series 40

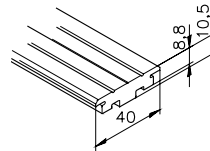

Profile mk 2038.30

0.79 kg/m

Stock length	38.30.6100
Cut	38.30.

Used for \varnothing 6 mm guide rod

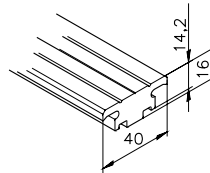

Profile mk 2038.31

1.07 kg/m

Stock length	38.31.6100
Cut	38.31.

Used for \varnothing 10 mm guide rod

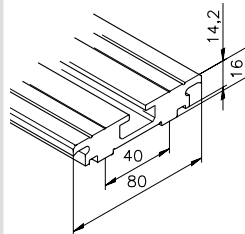

Profile mk 2038.32

0.44 kg/m

Stock length	38.32.6100
Cut	38.32.

Used for \varnothing 10 mm guide rod

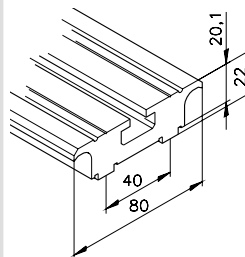

Profile mk 2038.33

2.96 kg/m

Stock length	38.33.6100
Cut	38.33.

Used for \varnothing 16 mm guide rod

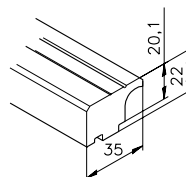

Profile mk 2038.07

1.50 kg/m

Stock length	38.07.6100
Cut	38.07.

Used for \varnothing 16 mm guide rod

Clamping Profiles for Series 40

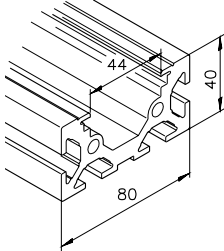

Profile mk 2038.75

3.41 kg/m

Stock length **38.75.6100**

Cut **38.75.**

Used for \varnothing 6 mm guide rod
 Internal guide

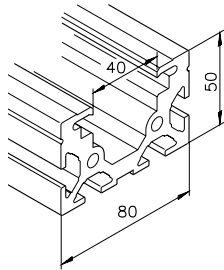

Profile mk 2038.77

4.34 kg/m

Stock length **38.77.6100**

Cut **38.77.**

Used for \varnothing 10 mm guide rod
 Internal guide

Clamping Profiles for Series 50

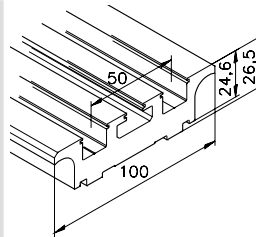

Profile mk 2038.46

3.97 kg/m

Stock length **38.46.6100**

Cut **38.46.**

Used for \varnothing 20 mm guide rod

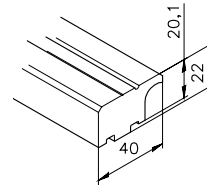

Profile mk 2038.12

1.77 kg/m

Stock length **38.12.6100**

Cut **38.12.**

Used for \varnothing 16 mm guide rod

Clamping Profiles for Series 50

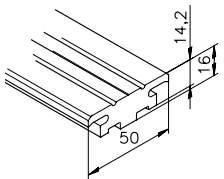

Profile mk 2038.41

1.36 kg/m

Stock length **38.41.6100**

Cut **38.41.**

Used for \varnothing 10 mm guide rod

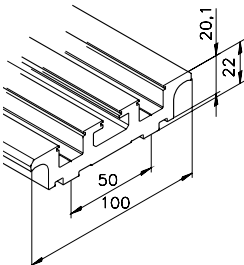

Profile mk 2038.44

3.09 kg/m

Stock length **38.44.6100**

Cut **38.44.**

Used for \varnothing 16 mm guide rod

Clamping Profiles for Series 60

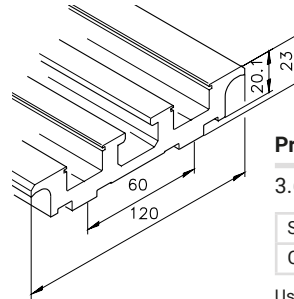

Profile mk 2038.36

3.62 kg/m

Stock length **38.36.6100**

Cut **38.36.**

Used for \varnothing 16 mm guide rod

Individual Components

Adapter Profiles for Series 25

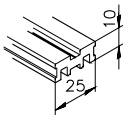

Profile mk 2038.50

0.46 kg/m

Stock length	38.50.6100
Cut	38.50.

Adapter Profiles for Series 50

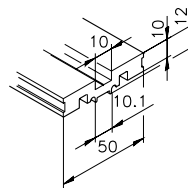

Profile mk 2038.60

1.04 kg/m

Stock length	38.60.6100
Cut	38.60.

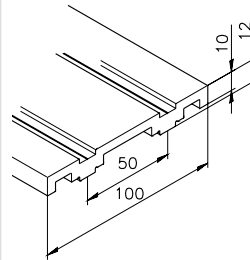

Profile mk 2038.61

1.90 kg/m

Stock length	38.61.6100
Cut	38.61.

Adapter Profiles for Series 40 and 50

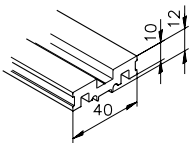

Profile mk 2038.55

0.77 kg/m

Stock length	38.55.6100
Cut	38.55.

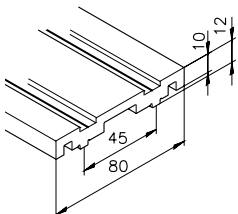

Profile mk 2038.56

1.67 kg/m

Stock length	38.56.6100
Cut	38.56.

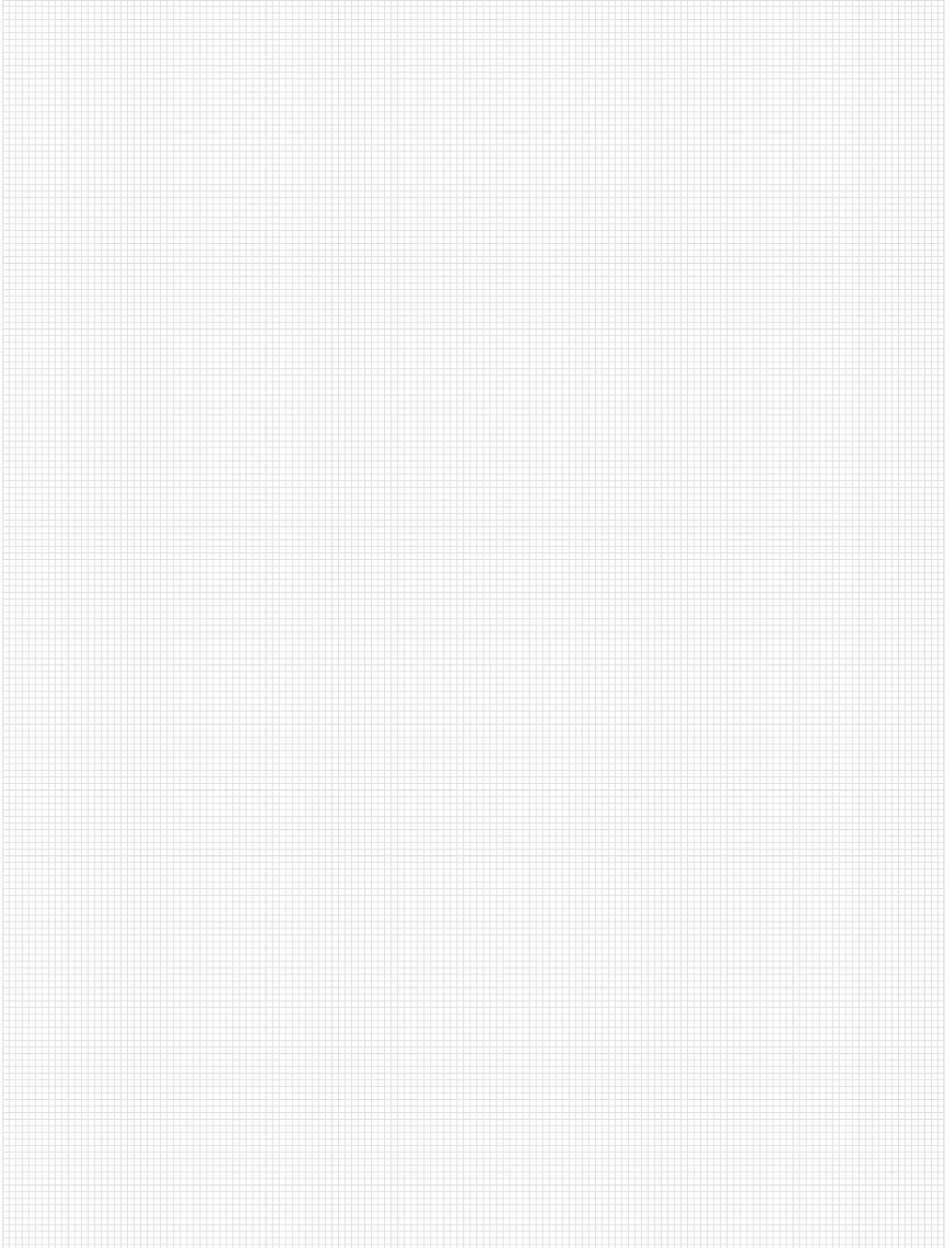

Individual Components

Guide Rollers

for $\varnothing 6$, $\varnothing 10$, $\varnothing 16$, $\varnothing 20$ guide rods

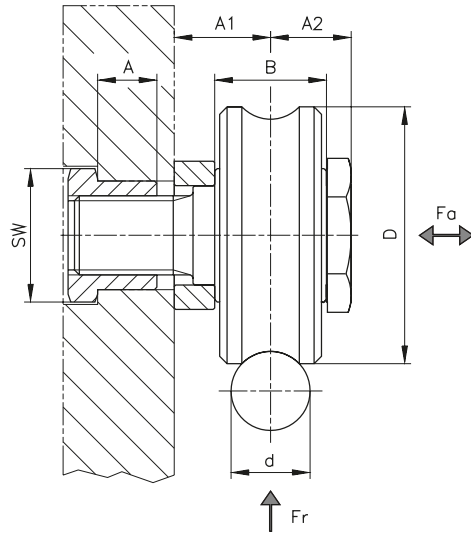
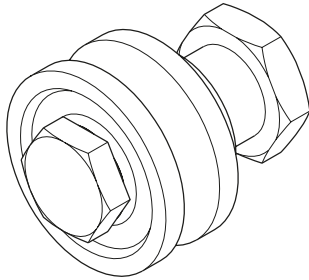

Technical Values

Item no.	D [mm]	B [mm]	A [mm]	A1 [mm]	A2 [mm]	SW [mm]	d for Rod	Consisting of:			
								Track roller	Bolt	Spacer ring	Bushing
B60.02.017 centric	17	8	6	7	7	13	$\varnothing 6^*$	K101100003	25.51.3201	25.51.3301	25.51.3101
B60.02.018 eccentric	17	8	6	7	7	13	$\varnothing 6^*$	K101100003	25.51.3201	25.51.3301	25.51.3102
B60.02.015 centric	35	15.9	12	12.5	13	22	$\varnothing 10^*$	K101100001	05.06.0003	14.04.0003	06.01.0013
B60.02.016 eccentric	35	15.9	12	12.5	13	22	$\varnothing 10^*$	K101100001	05.06.0003	14.04.0003	06.01.0014
B60.02.013 centric	52	22.6	12	19.5	16.3	27	$\varnothing 16^*$	K101100002	05.06.0007	14.04.0004	06.01.0018
B60.02.014 eccentric	52	22.6	12	19.5	16.3	27	$\varnothing 16^*$	K101100002	05.06.0007	14.04.0004	06.01.0017
B60.02.011 centric	72	25.8	18	22	18	36	$\varnothing 20^*$	K101100006	05.06.0009	14.04.0020	06.01.0021
B60.02.012 eccentric	72	25.8	18	22	18	36	$\varnothing 20^*$	K101100006	05.06.0009	14.04.0020	06.01.0022

*For item numbers, see page 351

Guide rollers also available in stainless steel for all diameters.

Load Specifications per Roller

Value	Roller for $\varnothing 6$ mm rod	Roller for $\varnothing 10$ mm rod	Roller for $\varnothing 16$ mm rod	Roller for $\varnothing 20$ mm rod
so*	4	4	4	4
Fr	175N	1000N	2000N	3250N
Fa	60N	300N	500N	825N
Static load capacity C_{ow}	890N	5100N	9500N	16600N
Dynamic load capacity C_w	1270N	8500N	16800N	29500N

*Static load safety factor against plastic deformation on the roller contact in the track roller.

For stainless steel guide rods, these values must be reduced by 30%.

Guide Rods

The stock length for Cf 53 and X46 Cr13 with corrosion resistance (magnetisable) is 4000 mm. For galvanised Cf 53 with corrosion protection, it is 3000 mm.

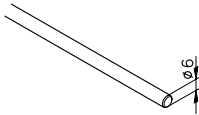

Guide rod 6
0.22 kg/m

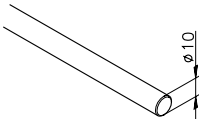

Guide rod 10
0.62 kg/m

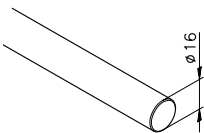

Guide rod 16
1.58 kg/m

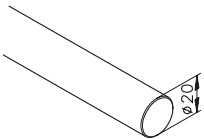

Guide rod 20
2.47 kg/m

Item no.

Cf 53	Cf 53**	X46 Cr13
11,213	11,213	14,034

Wipers

Polyamide

The wipers act as a safety element (for protection against pinch points while guiding the roller) and also wipe coarse dirty from the guide rod.

With the wipers for rod diameters 10 and 16, a sealing lip clings to the guide rod and wipes away even finer particles.

The wipers for rod diameters 10 and 16 are also available on request with felt strips and lubrication nipples for lubrication with oil.

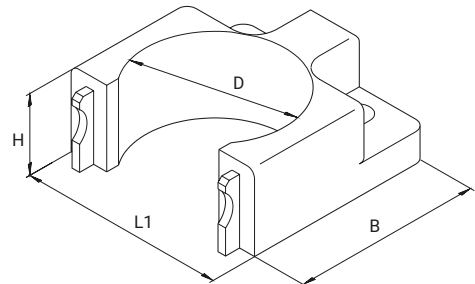

Technical Values

	Cf 53	Cf 53**	X46 Cr13	Item no.	d for Rod	L1 [mm]	B [mm]	H [mm]	D [mm]
ϕ 6 mm	7003AK....*	7003DC....*	7003EC....*	B03.00.014	ϕ 6***	25	22.5	11	19
ϕ 10 mm	7003AA....*	7003DH....*	7003EH....*	B03.00.003	ϕ 10	50	46	20	37
ϕ 16 mm	7003AM....*	7003DP....*	7003EP....*	B03.00.004	ϕ 16	70	64	30	56
ϕ 20 mm	7003CM....*	7003DT....*	7003ET....*	B03.00.013	ϕ 20***	100	80	35	76

...* Shaft length in mm
** Galvanised

***Wiper without sealing lip

Series 25 Linear Units

Profile Guide PF 6-38.20/50

The profile guide PF 6-38.20 with or without an adapter profile can be combined with the profiles from series 25 and the roller carriage shown on the next page. When combined, they form a linear unit.

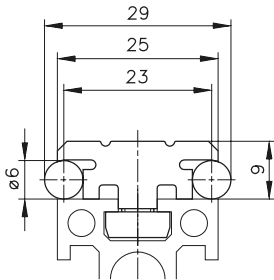
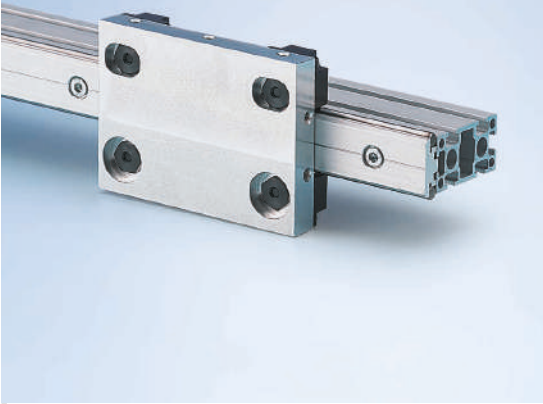

Profile guide PF 6-38.20
B51.04.025

1.5 kg/m
L1 up to 6000 mm

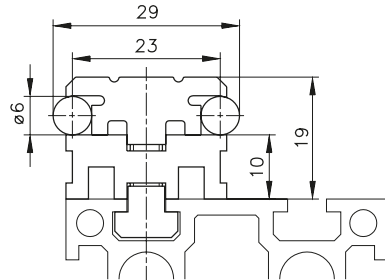

Profile Guide PF 6-38.20/50
B51.04.029

With adapter profile
2 kg/m
L1 up to 6000 mm

Borehole spacing specifications

Scope of application: $75 \leq L1 \leq 6000$

$12.5 \leq A < 37.5$

$$N = \frac{L1 - (2 \times A)}{50} + 1$$

L1 = length of the profile guide

A = distance from the first borehole to the profile edge

N = number of screws

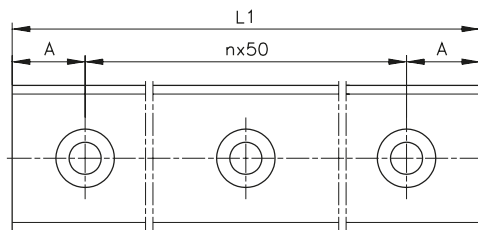

Roller Carriage LW 38.20-04

for Profile Guide PF 6-38.20/50

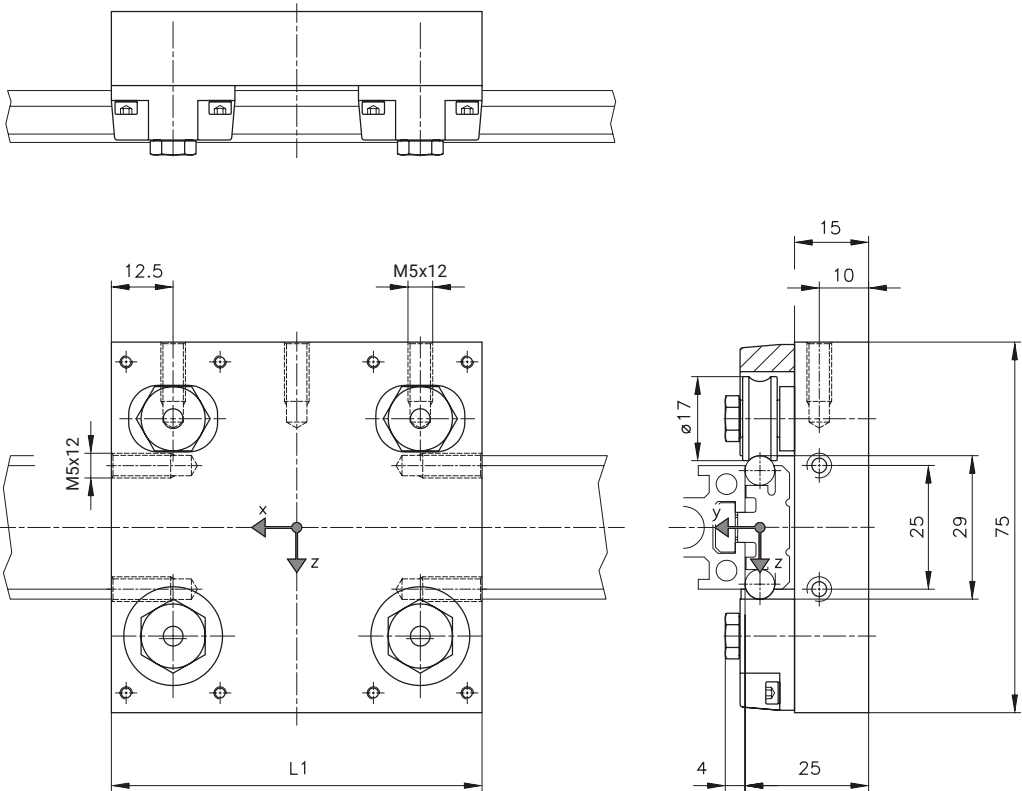

Technical Values

Item no.	Designation	L1 [mm]	F _{y0} [N]	F _{z0} [N]	M _{x0} [Nm]	M _{y0} [Nm]	M _{z0} [Nm]	m _{carriage} [kg]	Plate, individual
B90.25.041	LW 38.20-04	75	200	350	2.5	8.5	5	0.35	5009CA0075
B90.25.041	LW 38.20-04	100	200	350	2.5	13	8.0	0.43	5009CA0100

- Max. load specifications for $v \leq 10$ m/s and $a \leq 10$ m/s²; with $s_0 = 4$
- Max. acceleration $a = 50$ m/s² with reduced load
- Load application point max. 15 mm off-centre
- For X46 Cr13 rods and rollers, the load capacity must be reduced by 30%

Series 25 Linear Units

Profile Guide PF 6-38.21

The profile guide PF 6-38.21 can be combined with the profiles from series 25 and the roller carriage shown on the next page. When combined, they form a linear unit.

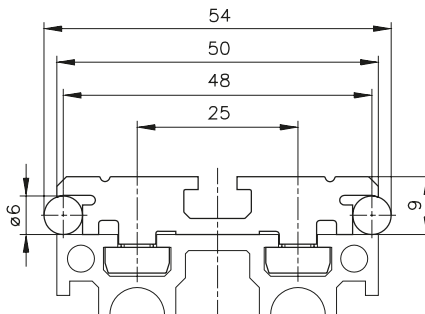
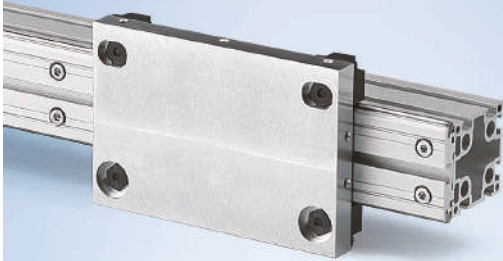

Profile guide PF 6-38.21

B51.04.030

2 kg/m
L1 up to 6000 mm

Borehole spacing specifications

Range: $100 \leq L1 \leq 6000$

$12.5 \leq A < 50$

$$N = \left(\frac{L1 - (2 \times A)}{75} + 1 \right) \times 2$$

L1 = length of the profile guide

A = distance from the first borehole to the profile edge

N = number of screws

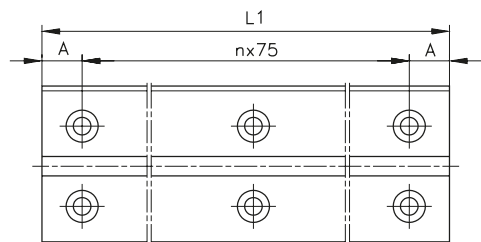

Roller Carriage LW 38.21-04

For profile guide PF 6-38.21

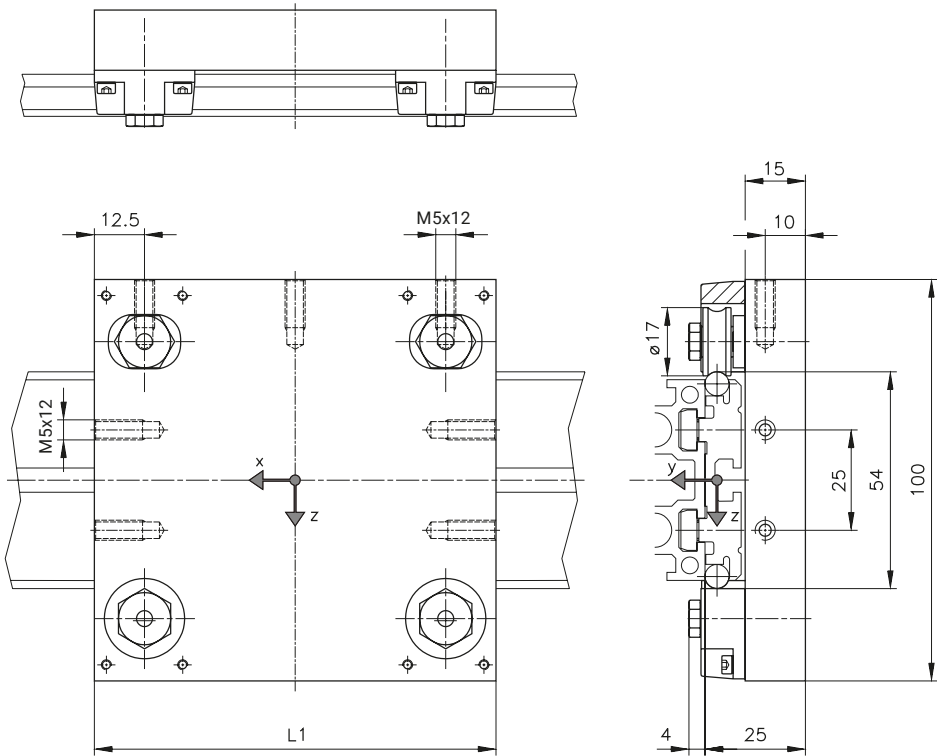

Technical Values

Item no.	Designation	L1 [mm]	F_{y0} [N]	F_{z0} [N]	M_{x0} [Nm]	M_{y0} [Nm]	M_{z0} [Nm]	m_{carriage} [kg]	Plate, individual
B90.25.042	LW 38.21-04	100	200	350	5	13	8	0.55	5009CB0100
B90.25.042	LW 38.21-04	150	200	350	5	21	13	0.75	5009CB0150

- Max. load specifications for $v \leq 10$ m/s and $a \leq 10$ m/s²; with $s_0 = 4$
- Max. acceleration $a = 50$ m/s² with reduced load
- Load application point max. 15 mm off-centre
- For X46 Cr13 rods and rollers, the load capacity must be reduced by 30%

Series 40 Linear Units

Profile Guide PF 6-38.30/55

The profile guide PF 6-38.30 with or without an adapter profile can be combined with the profiles from series 40 and the roller carriage shown on the next page. When combined, they form a linear unit.

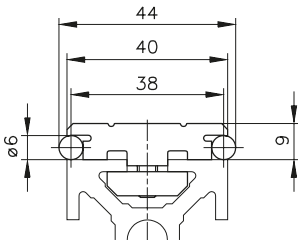
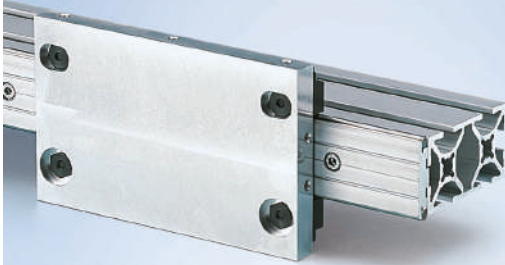

Profile Guide PF 6-38.30
B51.04.042

1.8 kg/m
L1 up to 6000 mm

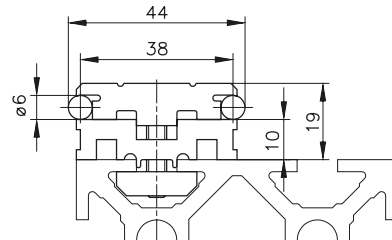

Profile Guide PF 6-38.30/55
B51.04.043

With adapter profile
2.6 kg/m
L1 up to 6000 mm

Borehole spacing specifications

Range: $75 \leq L1 \leq 6000$

$12.5 \leq A < 37.5$

$$N = \frac{L1 - (2 \times A)}{50} + 1$$

L1 = length of the profile guide

A = distance from the first borehole to the profile edge

N = number of screws

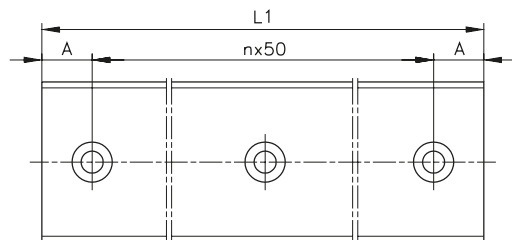

Roller Carriage LW 38.30-04

for Profile Guide PF 6-38.30/55

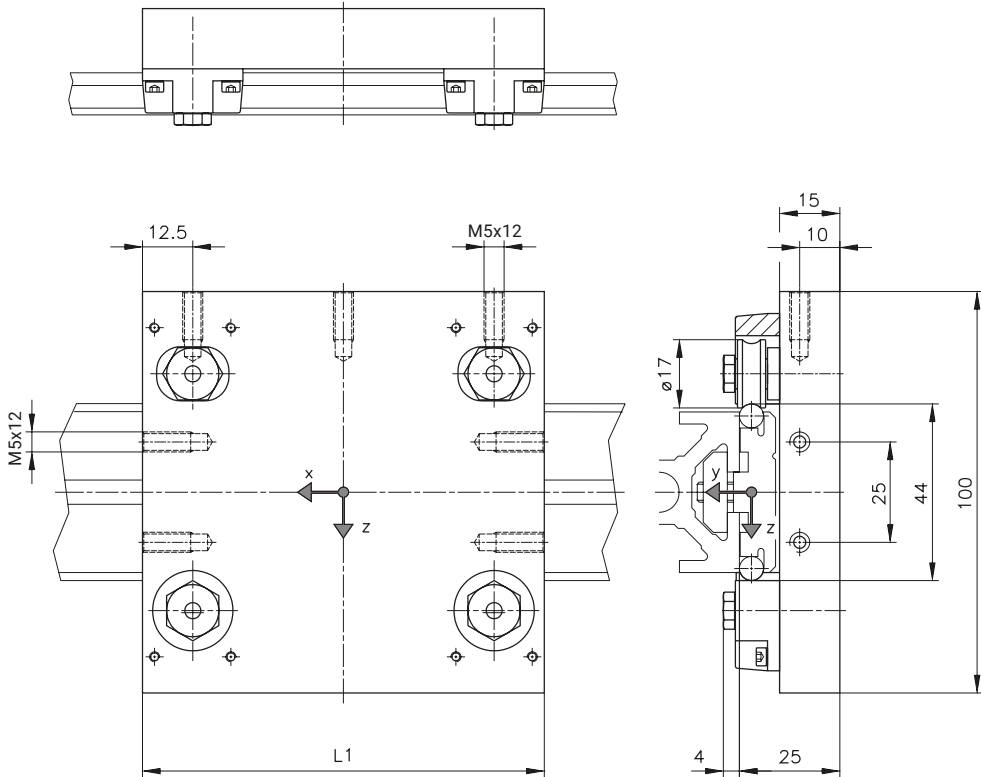

Technical Values

Item no.	Designation	L1 [mm]	F _{y0} [N]	F _{z0} [N]	M _{x0} [Nm]	M _{y0} [Nm]	M _{z0} [Nm]	m _{carriage} [kg]	Plate, individual
B90.40.041	LW 38.30-04	100	200	350	4	13	8	0.55	5009CC0100
B90.40.041	LW 38.30-04	160	200	350	4	23	14	0.8	5009CC0160

- Max. load specifications for $v \leq 10$ m/s and $a \leq 10$ m/s²; with $s_0 = 4$
- Max. acceleration $a = 50$ m/s² with reduced load
- Load application point max. 15 mm off-centre
- For X46 Cr13 rods and rollers, the load capacity must be reduced by 30%

Series 40 Linear Units

Profile Guide PF 10-38.31/55

The profile guide PF 10-38.31 with or without an adapter profile can be combined with the profiles from series 40 and the roller carriage shown on the next page. When combined, they form a linear unit.

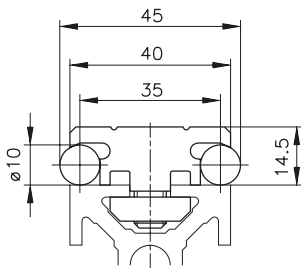
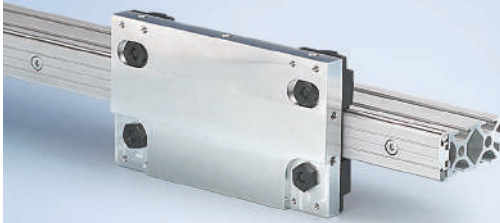

Profile Guide PF 10-38.31
B51.04.046

2.8 kg/m
L1 up to 6000 mm

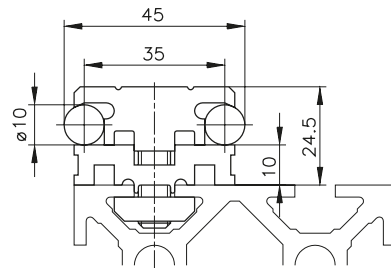

Profile Guide PF 10-38.31/55
B51.04.047

With adapter profile
3.6 kg/m
L1 up to 6000 mm

Borehole spacing specifications

Range: $150 \leq L1 \leq 6000$

$25 \leq A < 75$

$$N = \frac{L1 - (2 \times A)}{100} + 1$$

L1 = length of the profile guide

A = distance from the first borehole to the profile edge

N = number of screws

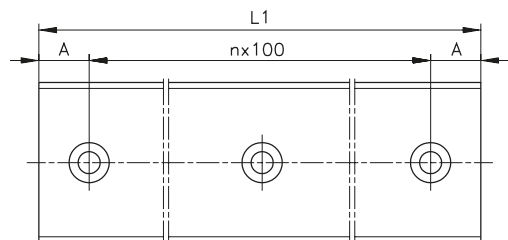

Roller Carriage LW 38.31-04

for Profile Guide PF 10-38.31/55

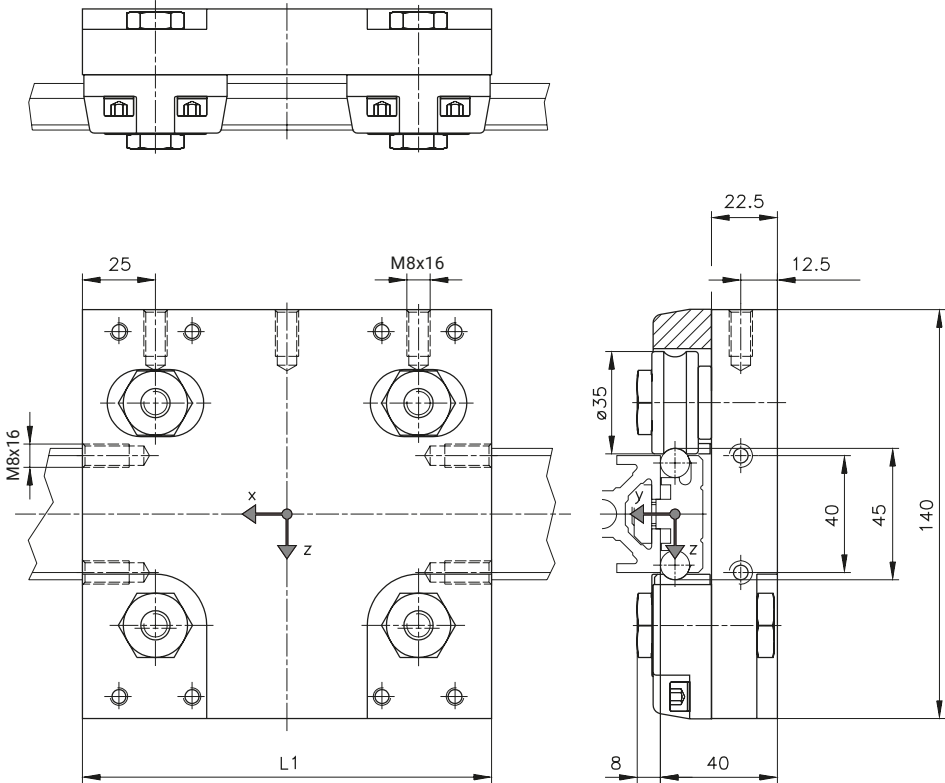

11

Technical Values

Item no.	Designation	L1 [mm]	F _{y0} [N]	F _{z0} [N]	M _{x0} [Nm]	M _{y0} [Nm]	M _{z0} [Nm]	m _{carriage} [kg]	Plate, individual
B90.40.042	LW 38.31-04	140	1000	2000	18	90	45	2	5009CD0140
B90.40.042	LW 38.31-04	240	1000	2000	18	190	95	2.8	5009CD0240

- Max. load specifications for $v \leq 10$ m/s and $a \leq 10$ m/s²; with $s_0 = 4$
- Max. acceleration $a = 50$ m/s² with reduced load
- Load application point max. 25 mm off-centre
- For X46 Cr13 rods and rollers, the load capacity must be reduced by 30%

Series 40 Linear Units

Profile Guide PF 10-38.32/56

The profile guide PF 10-38.32 with or without an adapter profile can be combined with the profiles from series 40 and the roller carriage shown on the next page. When combined, they form a linear unit.

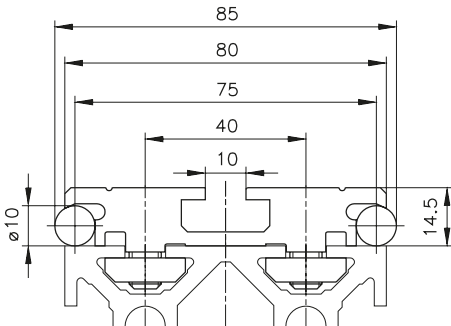
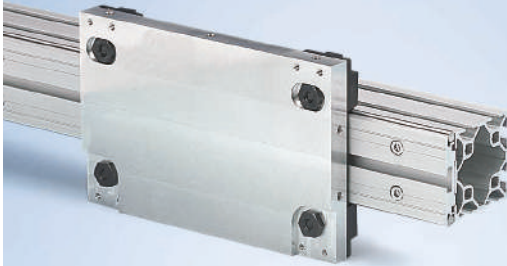

Profile Guide PF 10-38.32
B51.04.048

4 kg/m
L1 up to 6000 mm

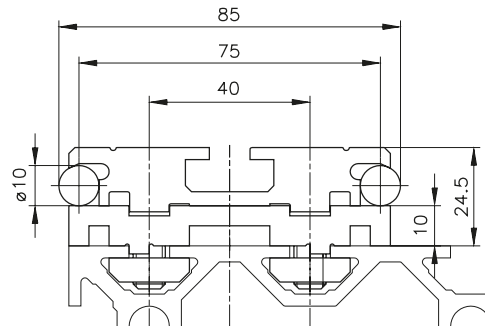

Profile Guide PF 10-38.32/56
B51.04.049

With adapter profile
5,8 kg/m
L1 up to 6000 mm

Borehole spacing specifications

Range: $200 \leq L1 \leq 6000$

$25 \leq A < 100$

$$N = \left(\frac{L1 - (2 \times A)}{150} + 1 \right) \times 2$$

L1 = length of the profile guide

A = distance from the first borehole to the profile edge

N = number of screws

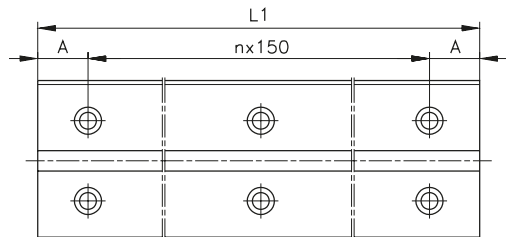

Roller Carriage LW 38.32-04

for Profile Guide PF 10-38.32/56

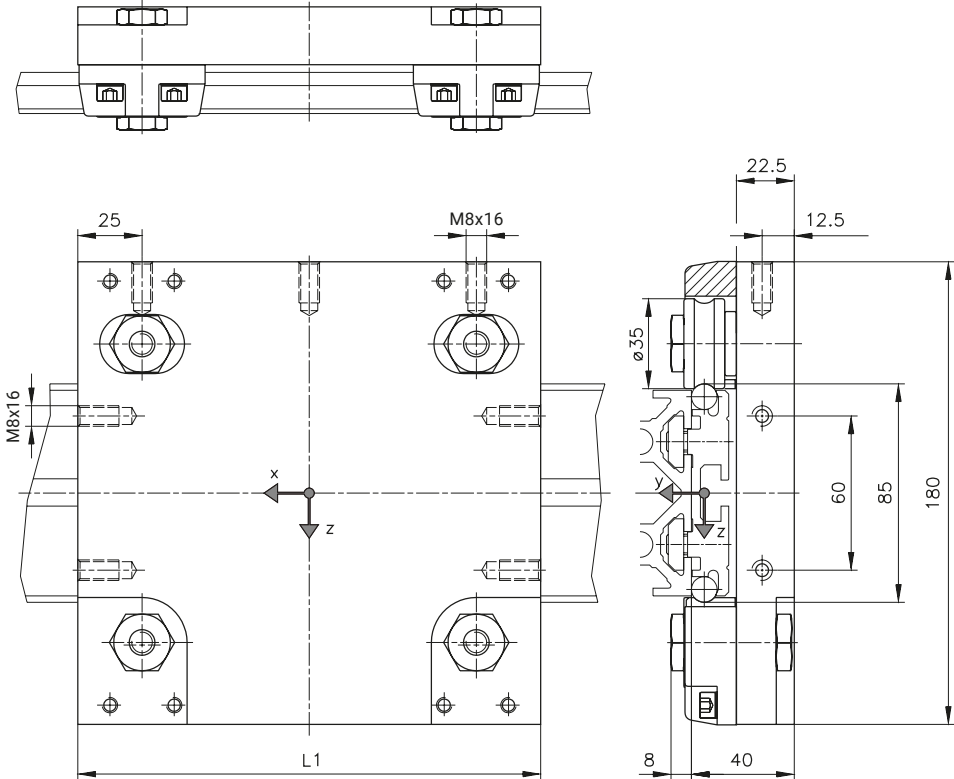

Technical Values

Item no.	Designation	L1 [mm]	F _{y0} [N]	F _{z0} [N]	M _{x0} [Nm]	M _{y0} [Nm]	M _{z0} [Nm]	m _{carriage} [kg]	Plate, individual
B90.40.043	LW 38.32-04	180	1000	2000	40	130	65	2.8	5009CE0180
B90.40.043	LW 38.32-04	280	1000	2000	40	230	115	3.8	5009CE0280

- Max. load specifications for $v \leq 10$ m/s and $a \leq 10$ m/s²; with $s_0 = 4$
- Max. acceleration $a = 50$ m/s² with reduced load
- Load application point max. 25 mm off-centre
- For X46 Cr13 rods and rollers, the load capacity must be reduced by 30%

Series 40 Linear Units

Profile Guide PF 16-38.33/56

The profile guide PF 16-38.33 with or without an adapter profile can be combined with the profiles from series 40 and the roller carriage shown on the next page. When combined, they form a linear unit.

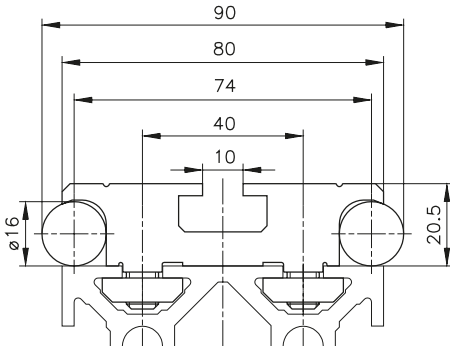

Profile Guide PF 16-38.33
B51.04.052

7 kg/m
L1 up to 6000 mm

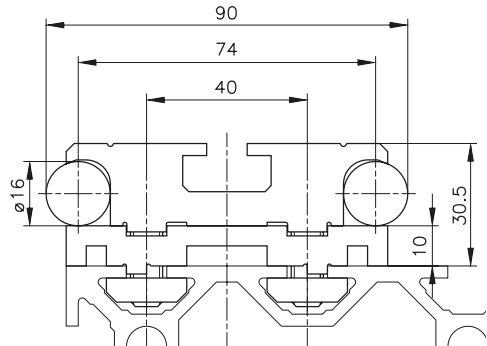

Profile Guide PF 16-38.33/56
B51.04.053

With adapter profile
8.8 kg/m
L1 up to 6000 mm

Borehole spacing specifications

Range: 150 ≤ L1 < 450 450 ≤ L1 < 6000

25 ≤ A < 75

125 ≤ A < 225

$$N = \left(\frac{L1 - (2 \times A)}{100} + 1 \right) \times 2$$

$$N = \left(\frac{L1 - (2 \times A)}{200} + 3 \right) \times 2$$

L1 = length of the profile guide

A = distance from the first borehole to the profile edge

N = number of screws

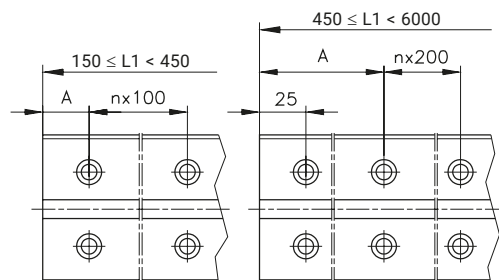

Roller Carriage LW 38.33-04

for Profile Guide PF 16-38.33/56

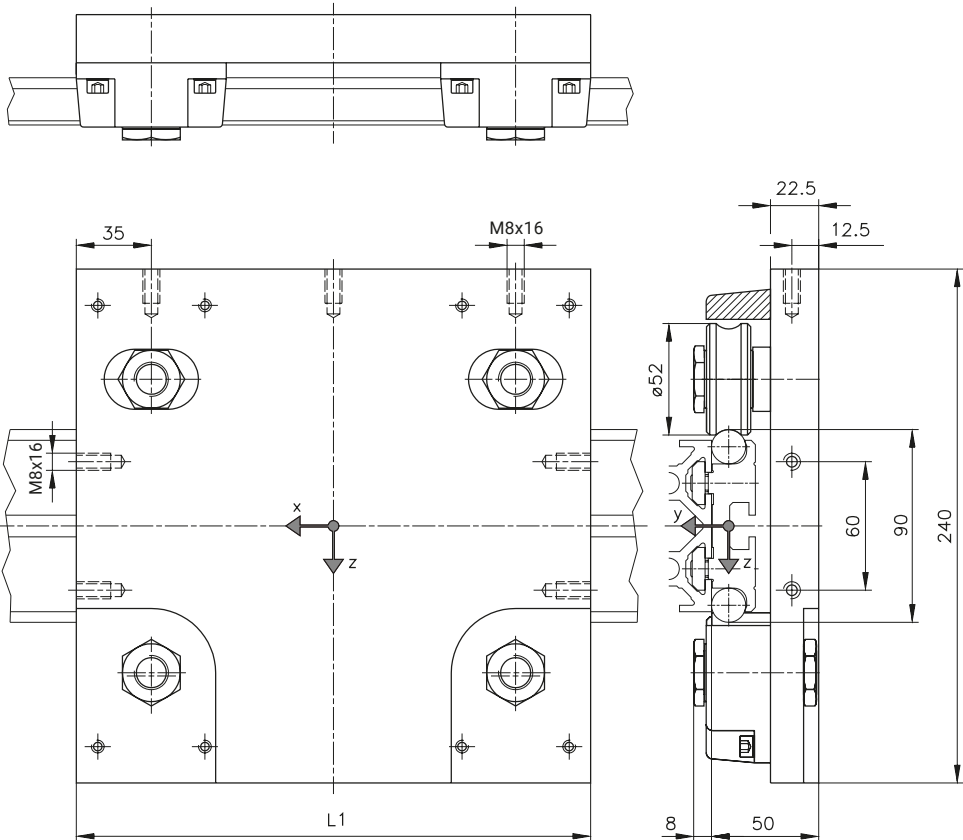

Technical Values

Item no.	Designation	L1 [mm]	F _{y0} [N]	F _{z0} [N]	M _{x0} [Nm]	M _{y0} [Nm]	M _{z0} [Nm]	m _{carriage} [kg]	Plate, individual
B90.40.044	LW 38.33-04	240	1600	4000	60	340	140	5.5	5009CF0240
B90.40.044	LW 38.33-04	400	1600	4000	60	660	260	8	5009CF0400

- Max. load specifications for $v \leq 10$ m/s and $a \leq 10$ m/s²; with $s_0 = 4$
- Max. acceleration $a = 50$ m/s² with reduced load
- Load application point max. 30 mm off-centre
- For X46 Cr13 rods and rollers, the load capacity must be reduced by 30%

Series 40 Linear Units

Internal Profile Guide PF 6-38.75

The profile guide PF 6-38.75 can be combined with the roller carriage shown on the next page. When combined, they form a linear unit.

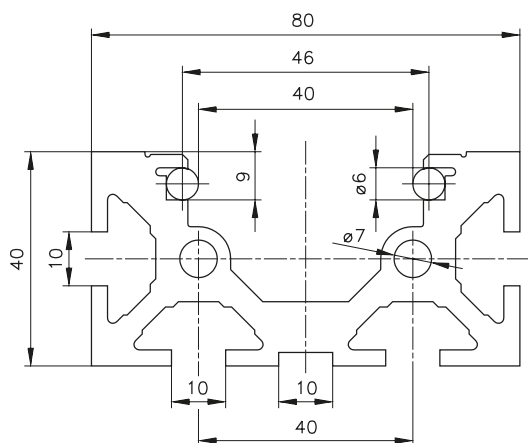

Profile Guide PF 6-38.75
B51.04.140

3.9 kg/m
L1 up to 6000 mm

Roller Carriage LW 38.75-44

For profile guide PF 6-38.75

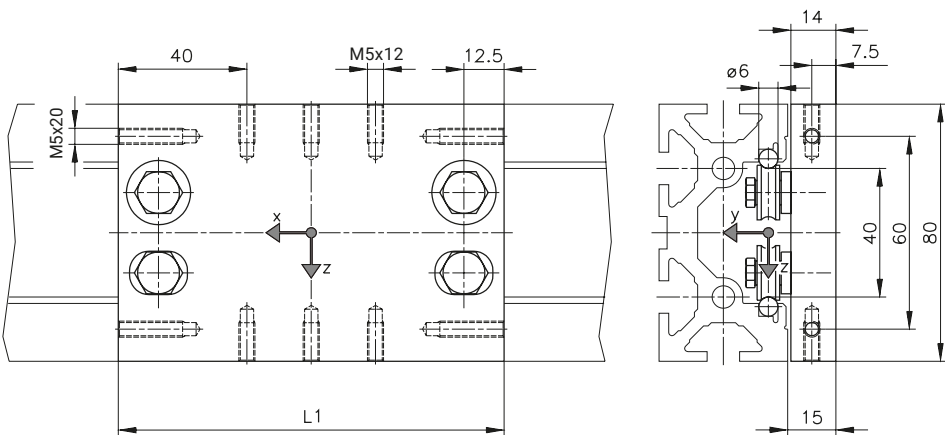
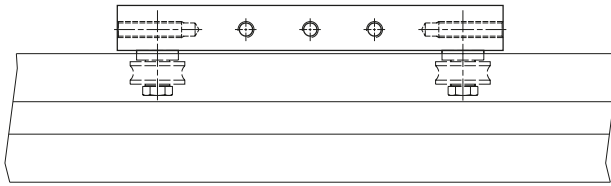

Technical Values

Item no.	Designation	L1 [mm]	F _{y0} [N]	F _{z0} [N]	M _{x0} [Nm]	M _{y0} [Nm]	M _{z0} [Nm]	m _{carriage} [kg]	Plate, individual
B90.40.441	LW 38.75-44	120	200	350	5	15	10	0.5	5009CN0120

- Max. load specifications for $v \leq 10$ m/s and $a \leq 10$ m/s²; with $s_0 = 4$
- Max. acceleration $a = 50$ m/s² with reduced load
- Load application point max. 15 mm off-centre
- For X46 Cr13 rods and rollers, the load capacity must be reduced by 30%

Series 40 Linear Units

Internal Profile Guide PF 10-38.77

The profile guide PF 10-38.77 can be combined with the roller carriage shown on the next page. When combined, they form a linear unit.

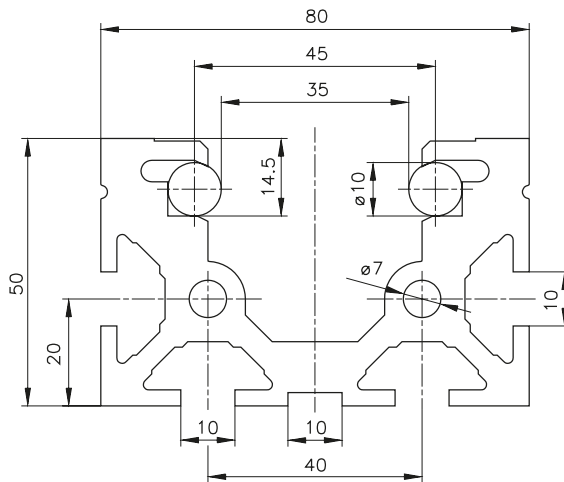

Profile guide PF 10-38.77

B51.04.142

5.6 kg/m
L1 up to 6000 mm

Roller Carriage LW 38.77-44

For profile guide PF 10-38.77

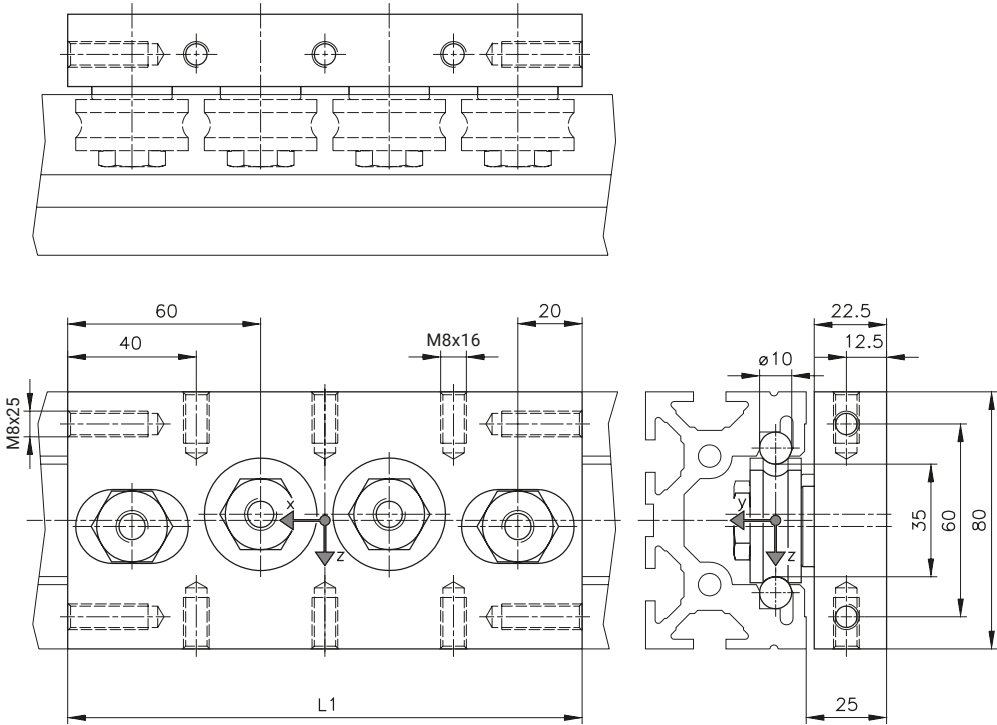

Technical Values

Item no.	Designation	L1 [mm]	F _{y0} [N]	F _{z0} [N]	M _{x0} [Nm]	M _{y0} [Nm]	M _{z0} [Nm]	m _{carriage} [kg]	Plate, individual
B90.40.443	LW 38.77-44	160	1000	1500	20	60	40	1.5	5009CO0160

- Max. load specifications for $v \leq 10$ m/s and $a \leq 10$ m/s²; with $s_0 = 4$
- Max. acceleration $a = 50$ m/s² with reduced load
- Load application point max. 25 mm off-centre
- For X46 Cr13 rods and rollers, the load capacity must be reduced by 30%

Series 50 Linear Units

Profile Guide PF 10-38.41/60

The profile guide PF 10-38.41 with or without an adapter profile can be combined with the profiles from series 50 and the roller carriage shown on the next page. When combined, they form a linear unit.

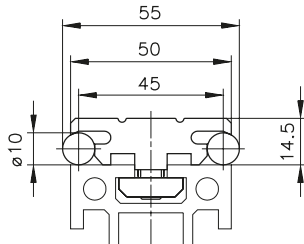
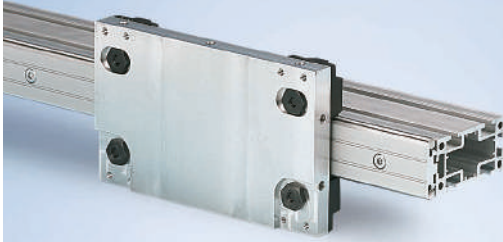

Profile guide PF 10-38.41
B51.04.020

3 kg/m
L1 up to 6000 mm

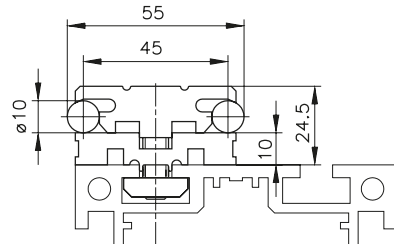

Profile Guide PF 10-38.41/60
B51.04.015

With adapter profile
4.2 kg/m
L1 up to 6000 mm

Borehole spacing specifications

Range: $150 \leq L1 \leq 6000$

$25 \leq A < 75$

$$N = \frac{L1 - (2 \times A)}{100} + 1$$

L1 = length of the profile guide

A = distance from the first borehole to the profile edge

N = number of screws

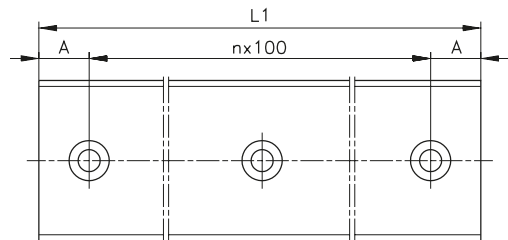

Roller Carriage LW 38.41-04

for Profile Guide PF 10-38.41/60

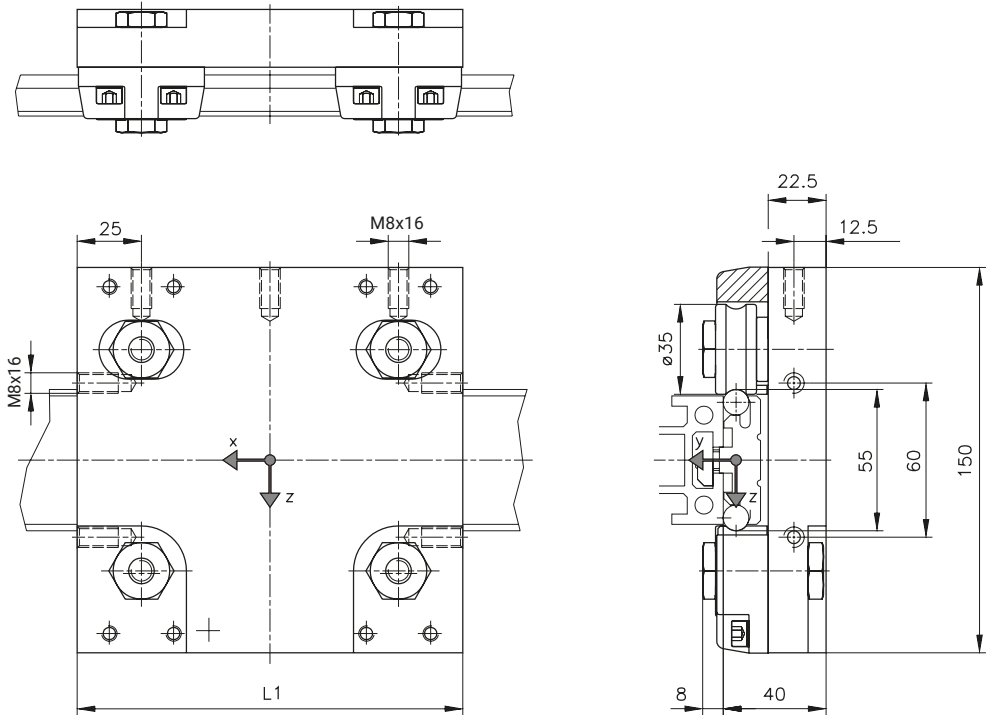

Technical Values

Item no.	Designation	L1 [mm]	F _{y0} [N]	F _{z0} [N]	M _{x0} [Nm]	M _{y0} [Nm]	M _{z0} [Nm]	m _{carriage} [kg]	Plate, individual
B90.50.042	LW 38.41-04	150	1000	2000	25	100	50	2.2	5009CG0150
B90.50.042	LW 38.41-04	250	1000	2000	25	200	100	3	5009CG0250

- Max. load specifications for $v \leq 10$ m/s and $a \leq 10$ m/s²; with $s_0 = 4$
- Max. acceleration $a = 50$ m/s² with reduced load
- Load application point max. 25 mm off-centre
- For X46 Cr13 rods and rollers, the load capacity must be reduced by 30%

Series 50 Linear Units

Profile Guide PF 16-38.44/61

The profile guide PF 16-38.44 with or without an adapter profile can be combined with the profiles from series 50 and the roller carriage shown on the next page. When combined, they form a linear unit.

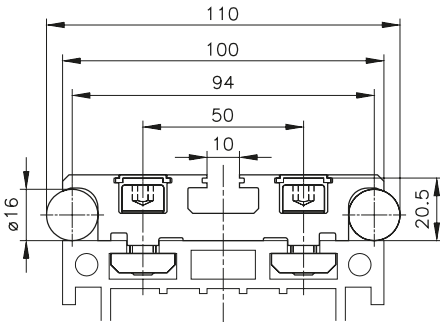
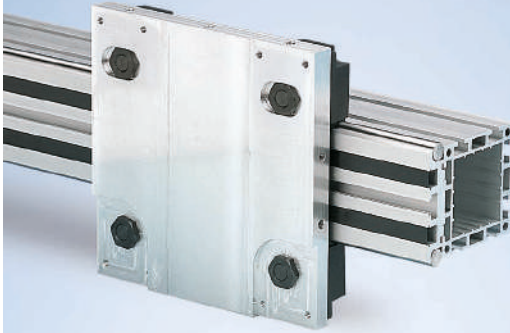

Profile guide PF 16-38.44
B51.04.004

6.8 kg/m
L1 up to 6000 mm

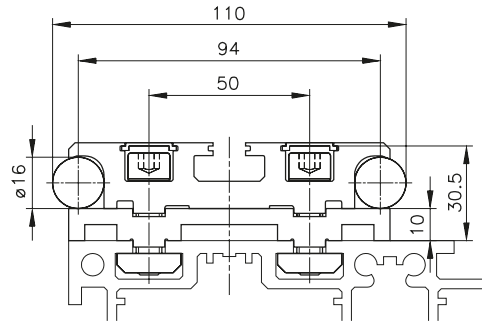

Profile guide PF 16-38.44/61
B51.04.016

With adapter profile
8.8 kg/m
L1 up to 6000 mm

Borehole spacing specifications

Range of app.: $150 \leq L1 < 450$ $450 \leq L1 < 6000$

$25 \leq A < 75$

$125 \leq A < 225$

$$N = \left(\frac{L1 - (2 \times A)}{100} + 1 \right) \times 2 \quad N = \left(\frac{L1 - (2 \times A)}{200} + 3 \right) \times 2$$

L1 = length of the profile guide

A = distance from the first borehole to the profile edge

N = number of screws

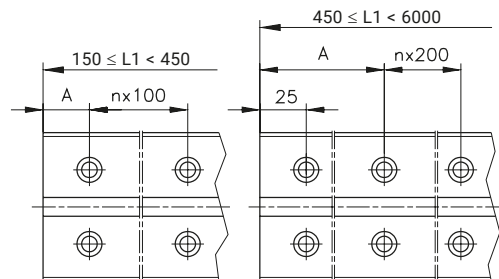

Roller Carriage LW 38.44-04

for Profile Guide PF 16-38.44/61

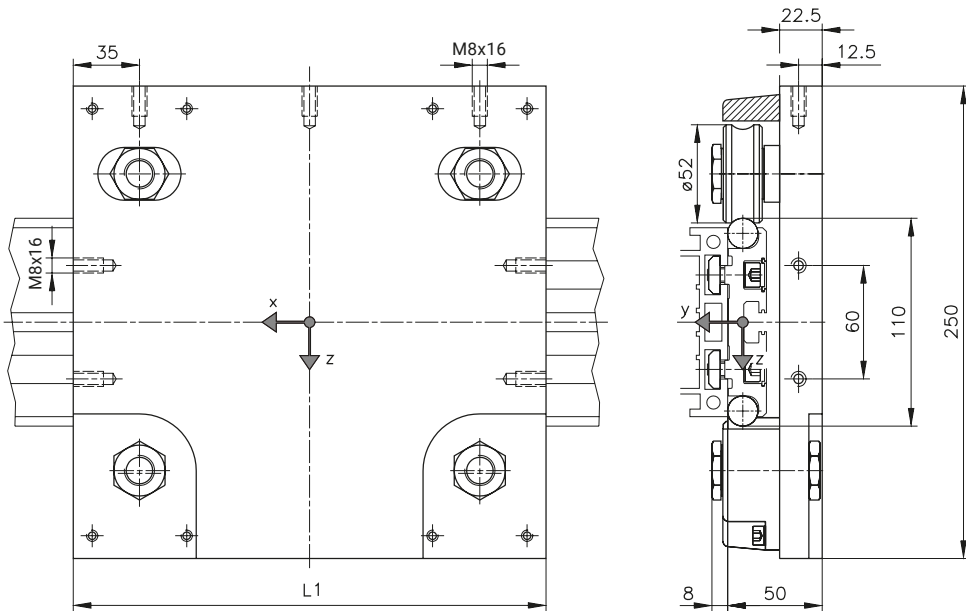
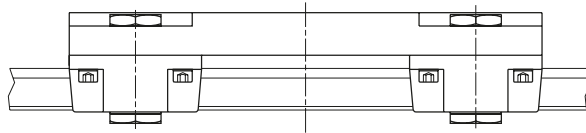

Technical Values

Item no.	Designation	L1 [mm]	F _{y0} [N]	F _{z0} [N]	M _{x0} [Nm]	M _{y0} [Nm]	M _{z0} [Nm]	m _{carriage} [kg]	Plate, individual
B90.50.044	LW 38.44-04	250	1600	4000	80	360	150	5.5	5009CI0250
B90.50.044	LW 38.44-04	450	1600	4000	80	760	300	8.5	5009CI0450

- Max. load specifications for $v \leq 10$ m/s and $a \leq 10$ m/s²; with $s_0 = 4$
- Max. acceleration $a = 50$ m/s² with reduced load
- Load application point max. 30 mm off-centre
- For X46 Cr13 rods and rollers, the load capacity must be reduced by 30%

Series 60 Linear Units

Profile guide PF 16-38.36

The profile guide PF 16-38.36 can be combined with the profiles from series 60 and the roller carriage shown on the next page. When combined, they form a linear unit.

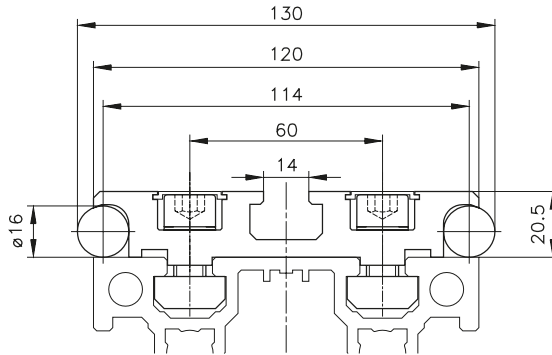
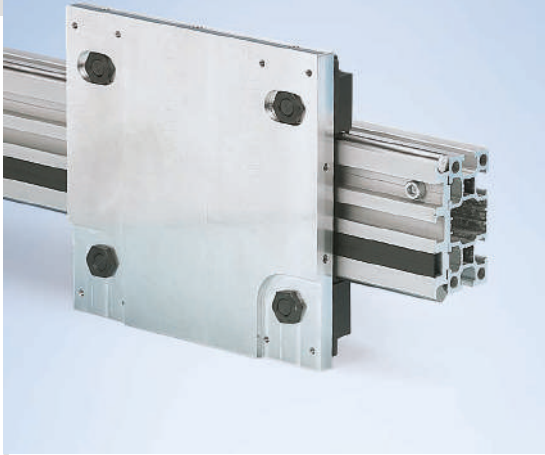

Profile guide PF 16-38.36
B51.04.109

9.5 kg/m
L1 up to 6000 mm

Borehole spacing specifications

Range of app.: $150 \leq L1 < 450$ $450 \leq L1 < 6000$

$25 \leq A < 75$

$125 \leq A < 225$

$$N = \left(\frac{L1 - (2 \times A)}{100} + 1 \right) \times 2$$

$$N = \left(\frac{L1 - (2 \times A)}{200} + 3 \right) \times 22$$

L1 = length of the profile guide

A = distance from the first borehole to the profile edge

N = number of screws

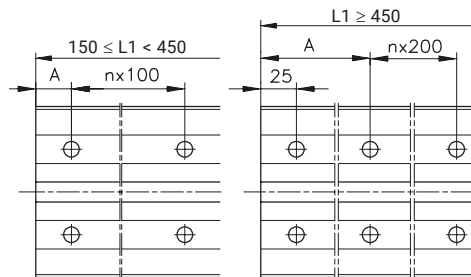

Roller Carriage LW 38.36-04

For profile guide PF 16-38.36

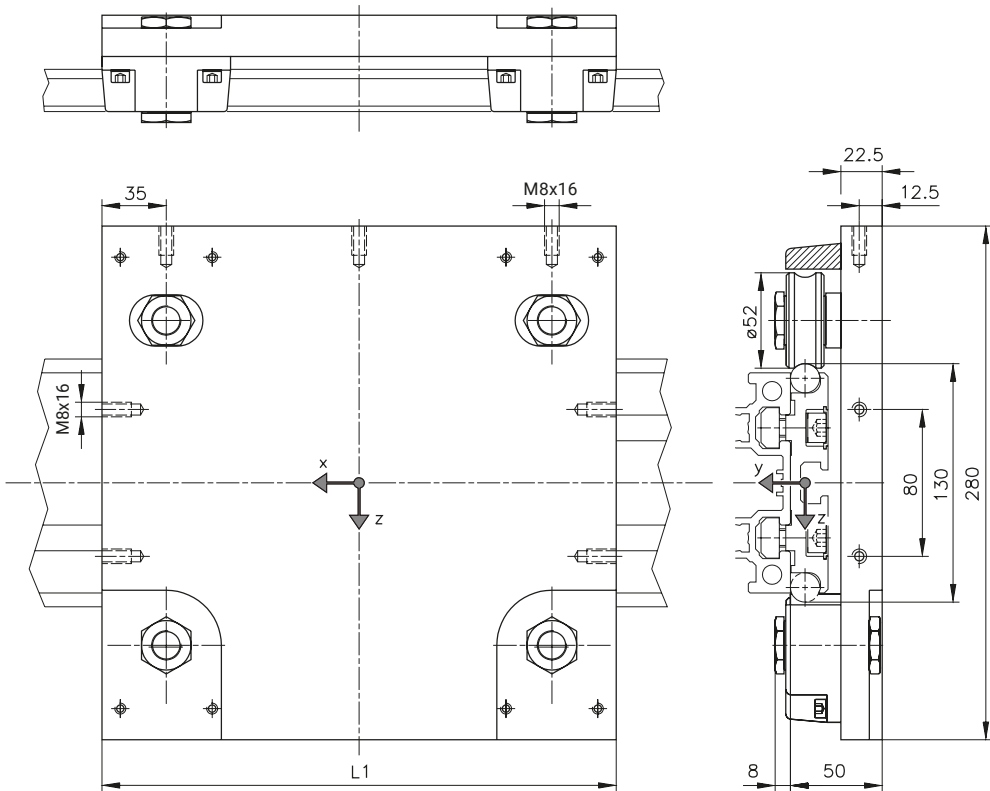

Technical Values

Item no.	Designation	L1 [mm]	F_{y0} [N]	F_{z0} [N]	M_{x0} [Nm]	M_{y0} [Nm]	M_{z0} [Nm]	m_{carriage} [kg]	Plate, individual
B90.60.042	LW 38.36-04	280	1600	4000	100	420	170	6.5	5009CL0280
B90.60.042	LW 38.36-04	480	1600	4000	100	820	330	10	5009CL0480

- Max. load specifications for $v \leq 10$ m/s and $a \leq 10$ m/s²; with $s_0 = 4$
- Max. acceleration $a = 50$ m/s² with reduced load
- Load application point max. 30 mm off-centre
- For X46 Cr13 rods and rollers, the load capacity must be reduced by 30%

Linear Modules LZR

Linear modules with timing belts (LZR) have a modular design and are installed on the track roller assemblies. Their basic components include the mounting profile, profile guide and carriage plate and the timing belt drive components required to transmit power, such as the pulleys and connectors.

The LZR design facilitates the attachment of motors as standard. With the appropriately drilled shafts, the pulleys allow the motor to be attached directly on any side. In addition, shaft ends for flanged mounting of a gearmotor with a hollow shaft, adaptations with a motor flange and coupling and an indirect drive are available on request.

For electromotive drives using a stepper motor or servomotor, we recommend using the optional single-piece drive shafts.

The linear modules can be combined in two-axis and three-axis systems and in area gantries and three-dimensional gantries.

Level of Accuracy that can be achieved by Linear Modules with Timing Belts

The LZR with a 8M-30-type timing belt can achieve the following values without a load:

Repeatability: 0.1 mm

Positioning accuracy: ± 0.2 mm

Reversal error: 0.2 mm

These values vary depending on the stroke length and application.

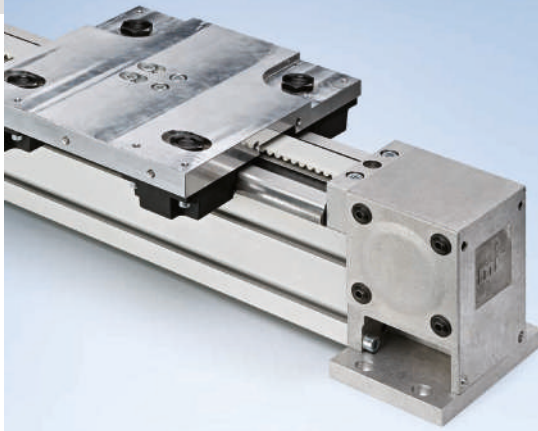

Order designation

LZR 2025-38.20-16

System designation

Mounting profile

Clamping profile

Timing belt width

Sample order

Linear module	LZR 2025-38.20-16
Item no.	B38.25.001
Stroke	=mm
Length	L =mm
Roller carriage length	L1 =mm
Drive shaft borehole	\varnothing =mm
Travel speed	v =m/s
Acceleration	a =m/s ²

Notes on the Load Specifications

For information about load specifications for track roller assemblies, refer to the information beginning on page 42.

Notes on the Load Specifications for Timing Belts

The standard timing belts used are PU (polyurethane) with steel cord tension members. Other types, including conductive belts, are available on request.

The maximum track roller assembly travel speed of $v = 10$ m/s can be achieved using timing belts with no reduction of the load capacities.

From $a > 10$ m/s² onwards, the values must be reduced by the usual load factors (e.g. without load peaks $s = 1$ to high load peaks $s = 2.5$).

The allowable tension loads are based on a 0.4% elongation of the timing belt.

The breaking strength of the belts is significantly higher. The normal usable belt pull strength (F_u) and required pretension (F_v) is approximately:

$$F_{\text{allowable}} = F_v + F_u \quad \text{with } F_v = F_u$$

Timing Belts	AT 5-16	5M-15	8M-30
F_{breaking}	3900 N	3600 N	14900 N
$F_{\text{allowable}}$	1200 N	1150 N	4000 N
$F_v = F_u$	600 N	575 N	2000 N

The usable starting torque results from the maximum usable belt pull strength, of the engaged teeth and the pitch diameter of the timing belt pulley.

The values for the mk LZR modules are:

Timing belt	AT 5-16	5M-15	8M-30
D_{Pitch}	41.4 mm	50.9 mm	71.3 mm
Z	26	32	28
M_{Drive}	12 Nm	15 Nm	70 Nm

Motor Selection/ Drive Design

For the drive selection, several factors must be considered, including the timing belt (especially the allowable belt pull strength and required stiffness) and the motor (especially the starting torque, the revolutions per minute and the resulting performance). The most important consideration is the required driving force. As a simple starting point for the calculations, the transition point from acceleration to constant speed can be used.

Constant acceleration (a = constant):

$$v = a \cdot t = \sqrt{2 \cdot a \cdot s}$$

Constant speed (v = constant):

$$v = \frac{s}{t}$$

Max. driving force:

$$F_{\text{Drive}} = F_a + F_{\text{Roll}} + F_{\text{Empty}} + F_{\text{Additional}}$$

$$F_a = m \cdot (a+g)$$

with m = moving mass in kg
 a = const. acceleration in m/s²
 $g = 10$ m/s², for vertical travel
 $g = 0$ m/s², for horizontal travel

$$F_{\text{Roll}} = F_N \cdot \mu_{\text{Roll}}$$

with $F_N = F_G$ for horizontal travel

$$\mu_{\text{Roll}} = 0.05 \text{ for lightly preloaded track roller}$$

$F_{\text{Empty}} = 50$ to 100 N depending on the module and pre-tension of the timing belt

$F_{\text{Additional}} =$ additional loads from the application

$$F_{\text{Drive}} = m \cdot (a+g) + F_N \cdot 0.05 + 100 \text{ N} + F_{\text{Additional}}$$

For timing belt selection:

Indicated $F_{\text{Drive}} < F_u$

For motor selection:

$$M_{\text{req}} = \frac{F_{\text{Drive}} \cdot D_{\text{Pitch}} [\text{m}]}{2 \cdot \eta}$$

$$n_{\text{req}} = \frac{v \cdot 60}{D_{\text{Pitch}} [\text{m}] \cdot \pi}$$

$$P_{\text{req}} = \frac{F_{\text{Drive}} \cdot v}{\eta}$$

With D_{Pitch} in m of timing belt pulley $\eta = 50$ too 75% depending on selected drive (gearbox, motor, etc.)

v in m/s

Linear Modules LZR

LZR 2000-38.41-15 with Plate Carriage

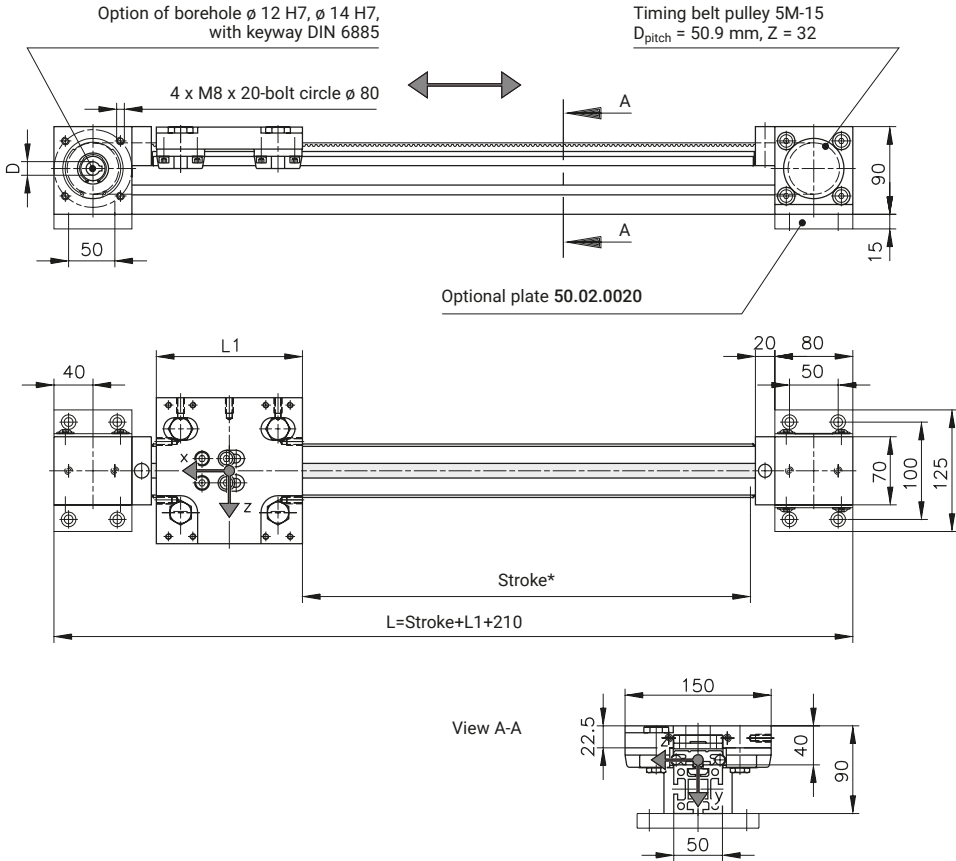

Load Specifications for LZR 2000-38.41-15 with Plate Carriage

Item no.	L1 [mm]	F_x^{**} [N]	F_{y0} [N]	F_{z0} [N]	M_{x0} [Nm]	M_{y0} [Nm]	M_{z0} [Nm]
B38.02.003	150	1150	1000	2000	25	100	50
B38.02.003	250	1150	1000	2000	25	200	100

* Maximum stroke between the mechanical stops. Note the discharge section!

** $F_x = F_{allowable}$; $F_u = 575$ N = F_v

LZR 2000-38.41-15 with Side Mounted Plate Carriage

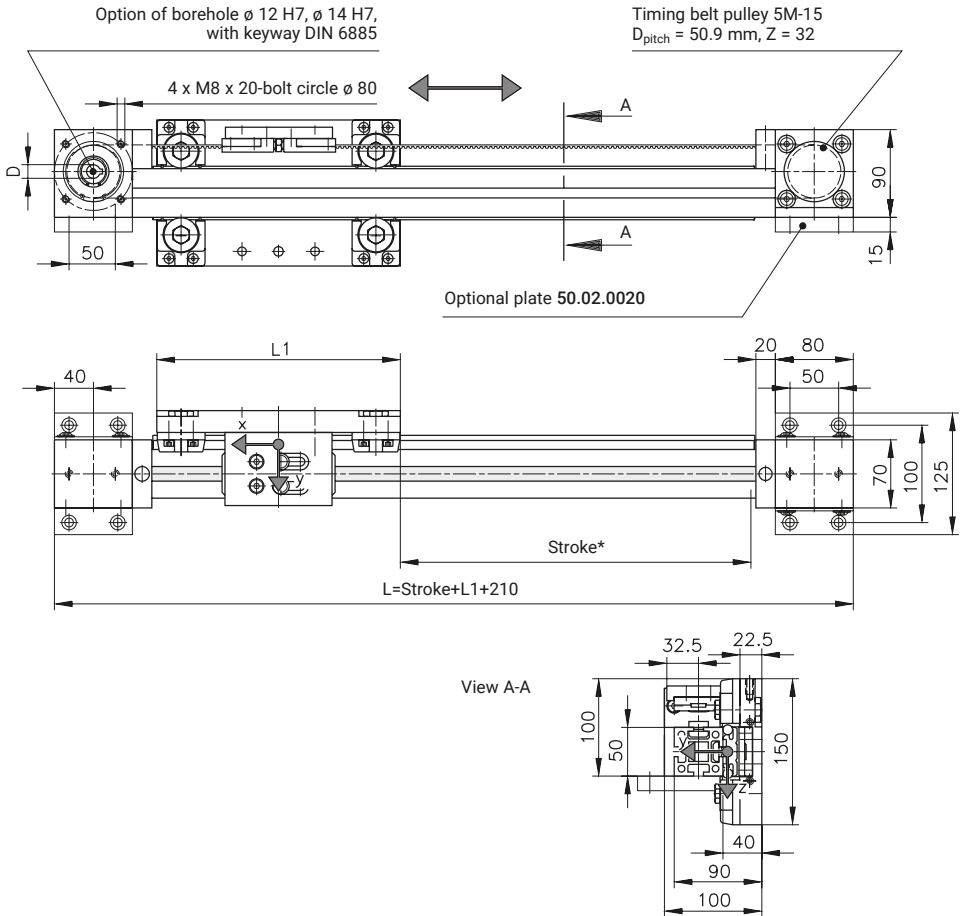

Load Specifications for LZR 2000-38.41-15 with Side Mounted Plate Carriage

Item no.	L1 [mm]	F_x^{**} [N]	F_{y0} [N]	F_{z0} [N]	M_{x0} [Nm]	M_{y0} [Nm]	M_{z0} [Nm]
B38.02.007	250	1150	1000	2000	25	200	100

* Maximum stroke between the mechanical stops. Note the discharge section!

** $F_x = F_{\text{allowable}}$; $F_u = 575\text{ N} = F_v$

Linear Modules LZR

LZR 2004-38.41-30 with Plate Carriage

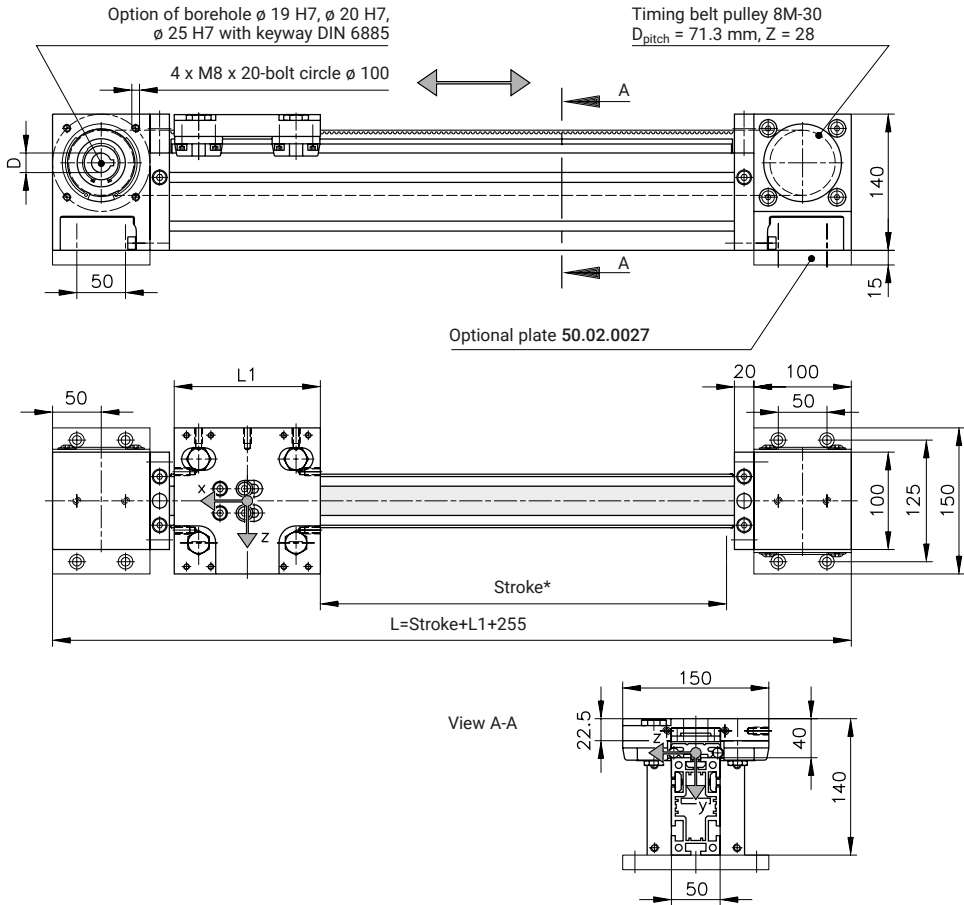

Load Specifications for LZR 2004-38.41-30 with Plate Carriage

Item no.	L1 [mm]	F_x^{**} [N]	F_{y0} [N]	F_{z0} [N]	M_{x0} [Nm]	M_{y0} [Nm]	M_{z0} [Nm]
B38.02.004	150	4000	1000	2000	25	100	50
B38.02.004	250	4000	1000	2000	25	200	100

* Maximum stroke between the mechanical stops. Note the discharge section!

** $F_x = F_{allowable}$; $F_u = 2000$ N = F_v

LZR 2004-38.44-30 with Side Mounted Plate Carriage

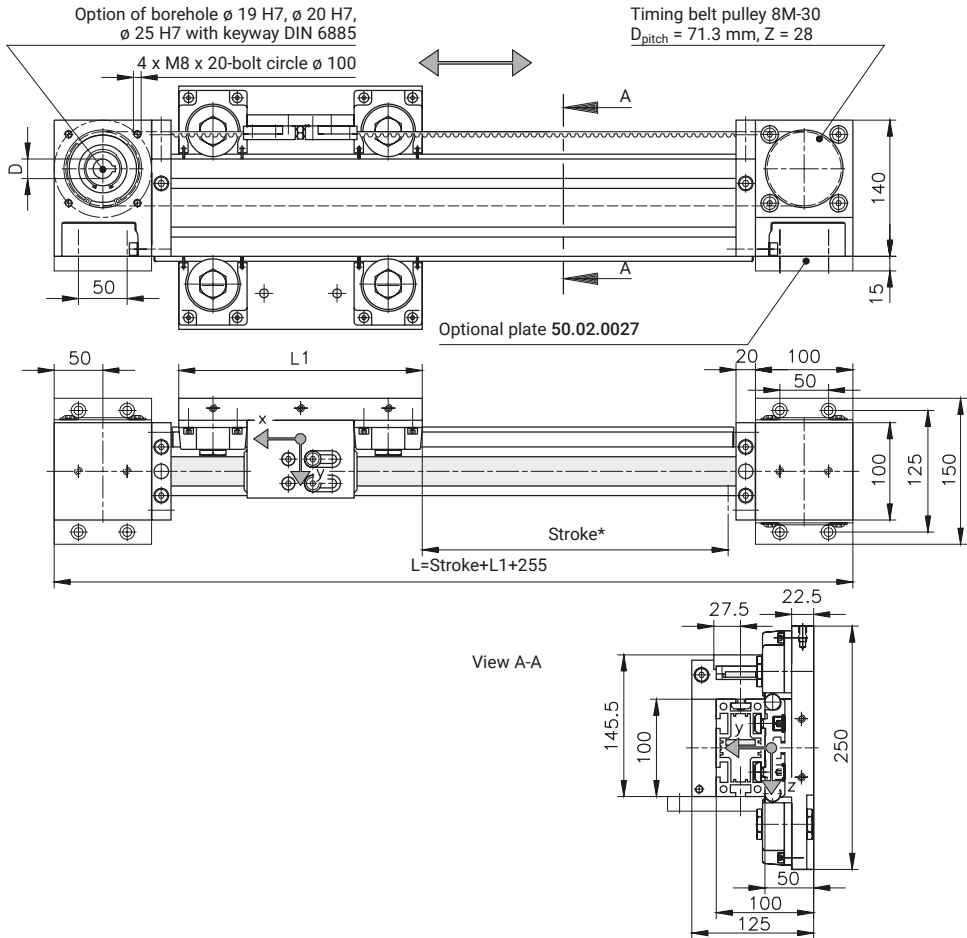

Load Specifications for LZR 2004-38.44-30 with Side Mounted Plate Carriage

Item no.	L1 [mm]	F_x^{**} [N]	F_{y0} [N]	F_{z0} [N]	M_{x0} [Nm]	M_{y0} [Nm]	M_{z0} [Nm]
B38.02.005	250	4000	1600	4000	80	350	150
B38.02.005	450	4000	1600	4000	80	760	300

* Maximum stroke between the mechanical stops. Note the discharge section!

** $F_x = F_{\text{allowable}}$; $F_u = 2000\text{ N} = F_v$

Linear Modules LZR

LZR 2005-38.44-30 with Plate Carriage

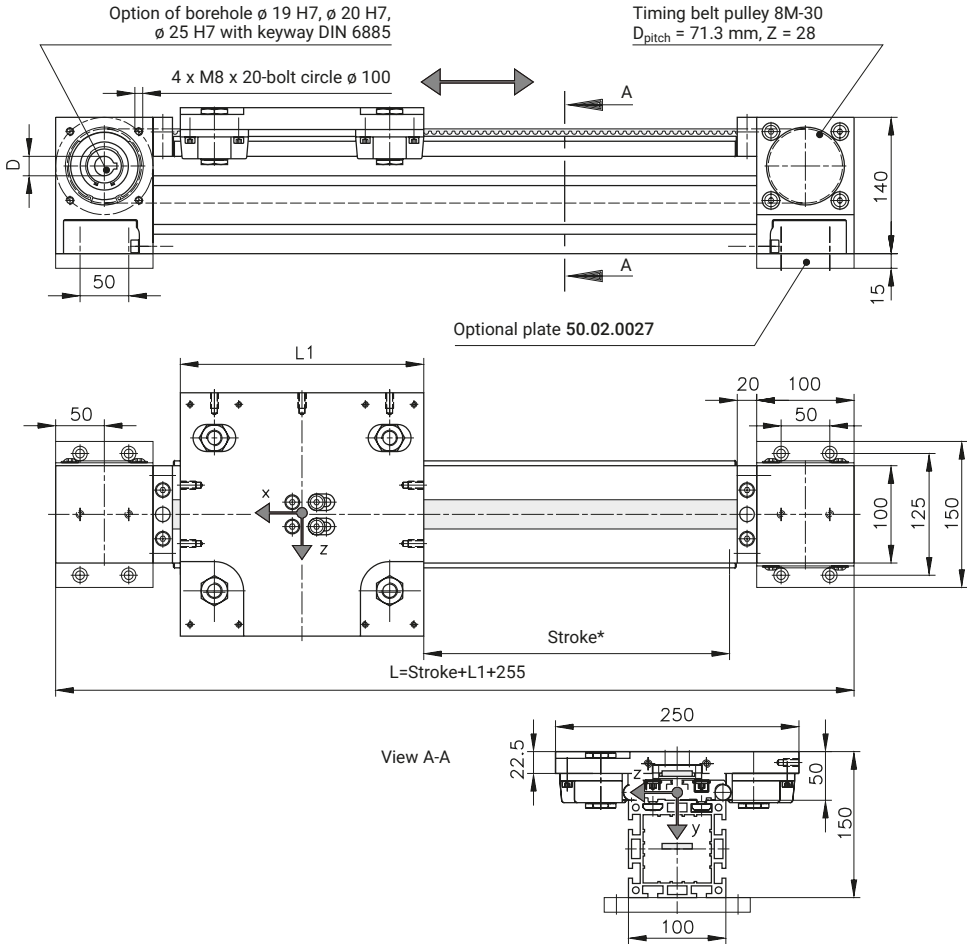

Load Specifications for LZR 2005-38.44-30 with Plate Carriage

Item no.	L1 [mm]	F_x^{**} [N]	F_{y0} [N]	F_{z0} [N]	M_{x0} [Nm]	M_{y0} [Nm]	M_{z0} [Nm]
B38.02.006	250	4000	1600	4000	80	350	150
B38.02.006	450	4000	1600	4000	80	760	300

* Maximum stroke between the mechanical stops. Note the discharge section!

** $F_x = F_{allowable}$; $F_u = 2000$ N = F_v

LZR 2005-38.44-30 with Side Mounted Plate Carriage

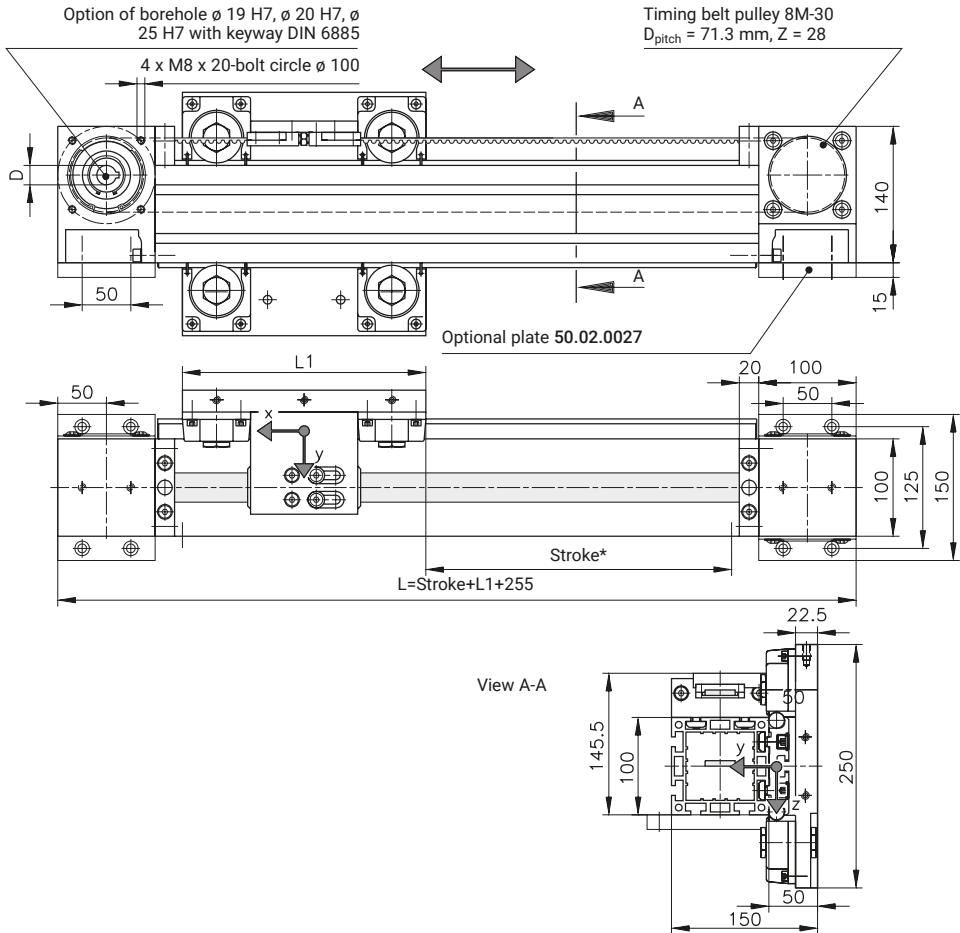

Load Specifications for LZR 2005-38.44-30 with Side Mounted Plate Carriage

Item no.	L1 [mm]	F _x ** [N]	F _{y0} [N]	F _{z0} [N]	M _{x0} [Nm]	M _{y0} [Nm]	M _{z0} [Nm]
B38.02.009	250	4000	1600	4000	80	350	150
B38.02.009	450	4000	1600	4000	80	760	300

* Maximum stroke between the mechanical stops. Note the discharge section!

** F_x = F_{allowable}; F_u = 2000 N = F_v

Linear Modules LZR

LZR 2011-38.44-30 with Plate Carriage

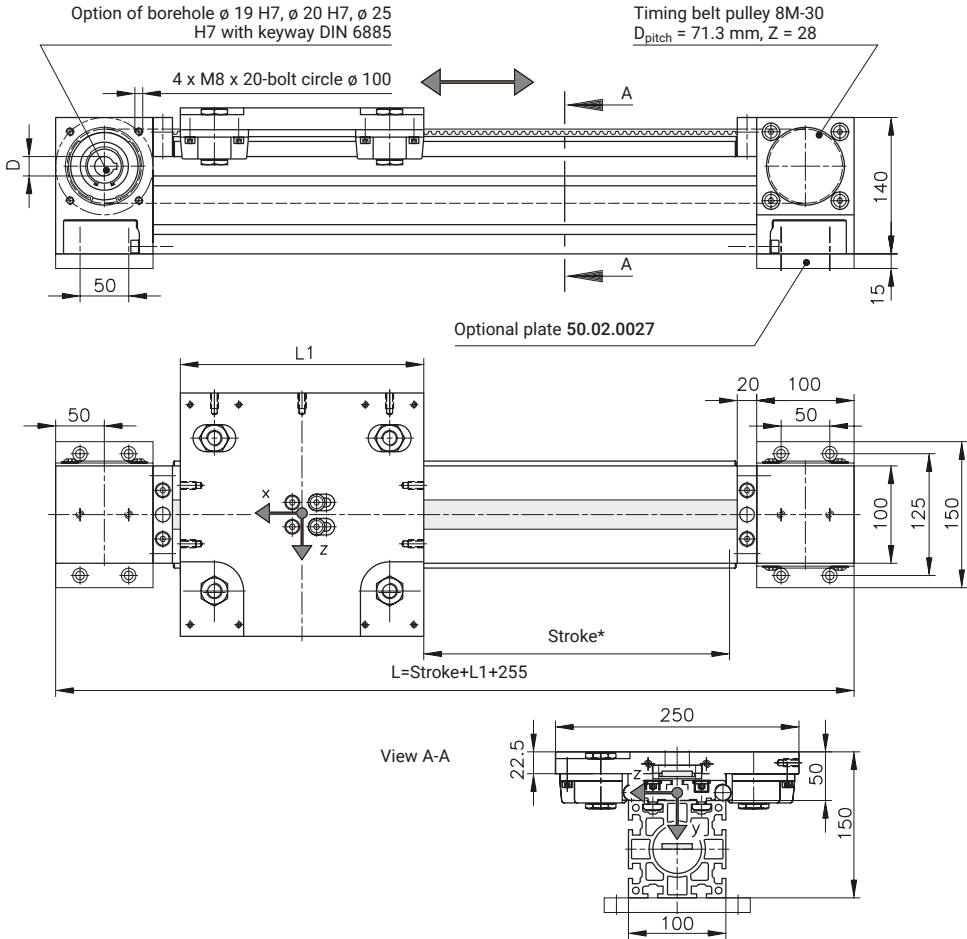

Load Specifications for LZR 2011-38.44-30 with Plate Carriage

Item no.	L1 [mm]	F _x ** [N]	F _{y0} [N]	F _{z0} [N]	M _{x0} [Nm]	M _{y0} [Nm]	M _{z0} [Nm]
B38.02.011	250	4000	1600	4000	80	350	150
B38.02.011	450	4000	1600	4000	80	760	300

* Maximum stroke between the mechanical stops. Note the discharge section!

** F_x = F_{allowable}; F_u = 2000 N = F_v

LZR 2011-38.44-30 with Side Mounted Plate Carriage

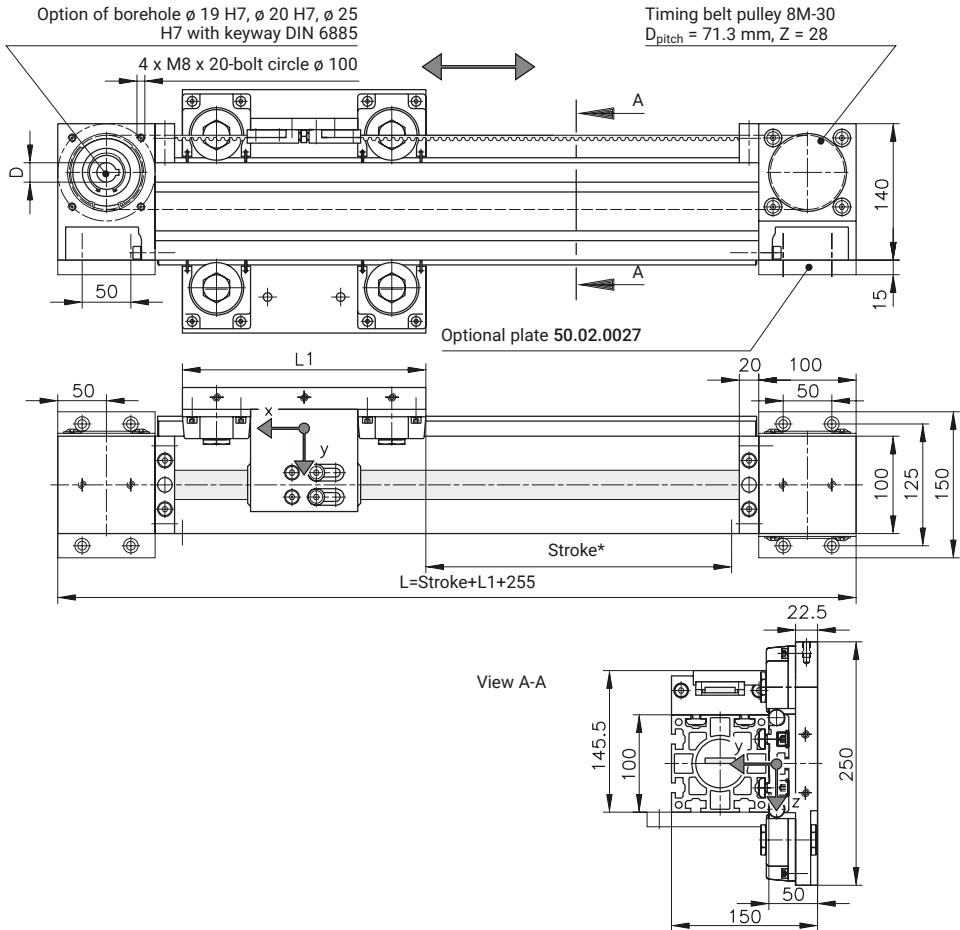

Load Specifications for LZR 2011-38.44-30 with Side Mounted Plate Carriage

Item no.	L1 [mm]	F_x^{**} [N]	F_{y0} [N]	F_{z0} [N]	M_{x0} [Nm]	M_{y0} [Nm]	M_{z0} [Nm]
B38.02.010	250	4000	1600	4000	80	350	150
B38.02.010	450	4000	1600	4000	80	760	300

* Maximum stroke between the mechanical stops. Note the discharge section!

** $F_x = F_{allowable}$; $F_u = 2000$ N = F_v

Recirculating Ball Bearing Guides



» Compact linear units with recirculating ball bearing guide. «

Recirculating ball bearing guides feature high load capacity along with outstanding precision. They have a very compact design. The recirculating ball bearing units can bear loads along multiple axes and are extremely stiff thanks to the steel rails mounted on the guide profile.

A recirculating ball bearing unit consists of a track and a guide carriage with four rows of interior ball bearings, which are recirculated in closed channels with plastic recirculation mechanisms. The recirculating ball bearing unit's roller carriage consists of hardened, ground steel and can be slid directly from the guard rail onto the track.

Our standard guide carriages are lightly pre-tensioned, making them suitable for most common applications. You may require higher pre-tension or no pre-tension, depending on your requirements. The guide carriages are custom-tailored to your specific conditions.

Benefits of mk Recirculating Ball Bearing Guides

- High load capacity and high stiffness
- Compact design
- Just one track for different types of roller carriage
- Lightly pre-tensioned (standard), available with play or high pre-tension
- Medium to high acceleration up to $a = 30\text{m/s}^2$
- Medium to high speed up to $v = 5\text{ m/s}$
- Four-row multi-axial recirculating ball bearing guide bears loads in all directions (forces and torques)
- High precision with appropriate contact surfaces

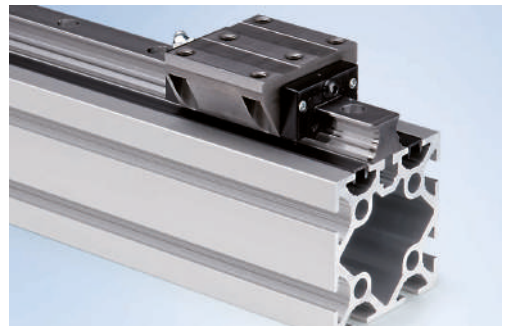
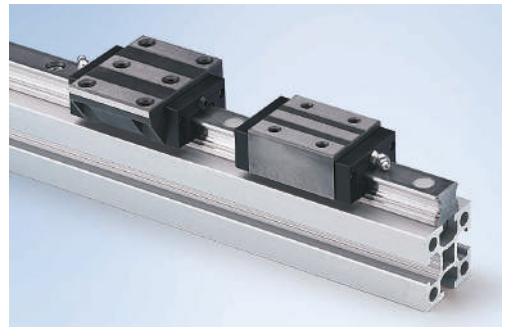
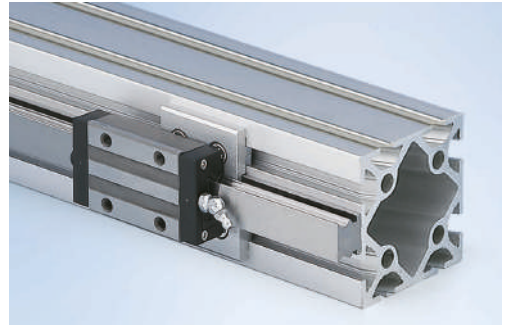
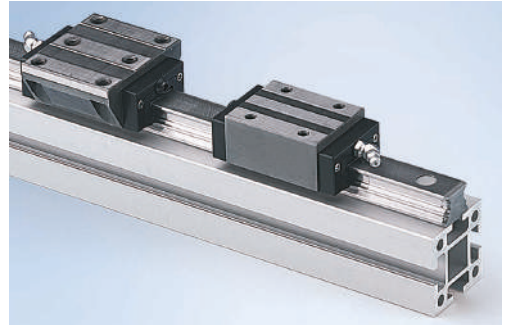

Recirculating Ball Bearing Guides

Recirculating Ball Bearing Units

General design

mk recirculating ball bearing units consist of a track and the guide carriage.

The roller carriage for the recirculating ball bearing unit is made from hardened and ground steel. Closed channels with plastic recirculation mechanisms recirculate the four rows of ball bearings. The roller carriage can be slid directly from the guard rail onto the track.

The recirculating ball bearing units can carry loads from any direction and have very rigid, heavy-duty linear guides.

The standard mk guide carriages are lightly pre-tensioned, making them suitable for most common applications. If multiple carriages are arranged on a rail or in parallel, then we recommend using carriages with no pre-tension and little play to provide better misalignment compensation and ease of movement.

For products with high rigidity or fluctuating loads, we recommend carriages with strong pre-tension and precise, rigid contact surfaces. mk can supply these versions on request.

The specified maximum load specifications already take into account a static safety factor of $s_0 = 5$ in relation to plastic deformation on the roller contact, and $s_0 = 2$ for screw connections with 8.8 screws.

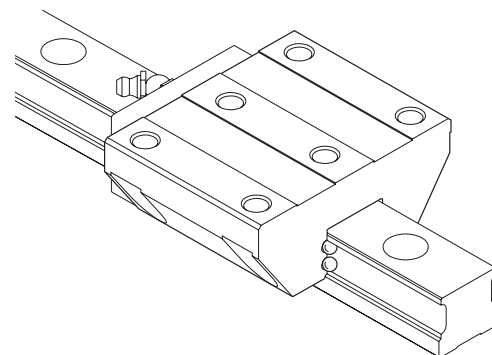

Sample order for a guide

Recirculating ball bearing guide KU 25.10

Item no. **B51.04.404**

Size =mm

Length L =mm

Sample order for a carriage

Guide carriage KU 25.11

Item no. **K116041125**

Size =mm

Carriage Normal

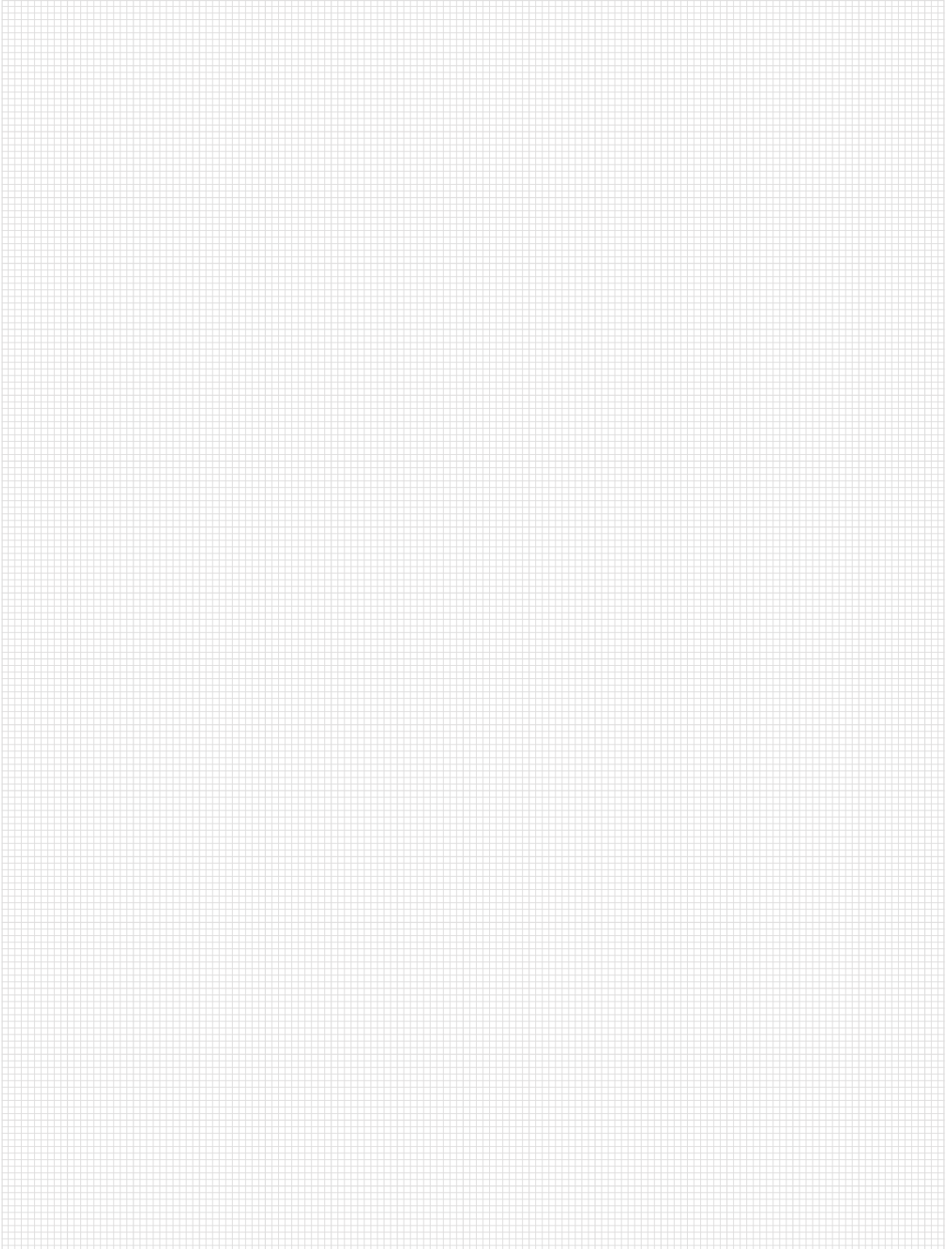

Recirculating Ball Bearing Guides

Recirculating Ball Bearing Guide KU 25.10

The track KU 25.10 must be combined into one unit with the guide carriages KU 25.11 and KU 25.13. However, they must be ordered individually.

The KU 25.10 track is especially suitable for Series 40 and 50. Due to its small contact surface, it is not suitable for the 14 mm slot in Series 60.

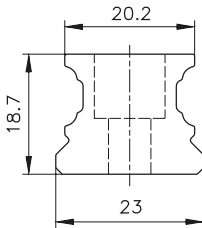
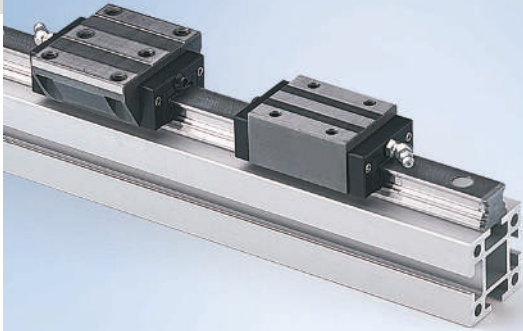

Track KU 25.10
K116041025

m = 2.7 kg/m

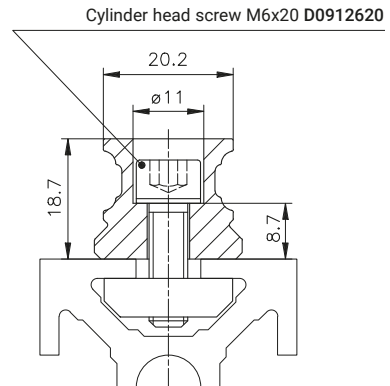

Track KU 25.10 with mounting elements
B51.04.404

Borehole spacing specifications

Support rail, L up to 1980 mm, single piece

Scope of application for A: $20 \leq A < 50$

$$N = \frac{L1 - (2 \times A)}{60} + 1 \text{ (+1 per joint)}$$

L1 = length of the support rail

A = distance from the first borehole to the profile edge (symmetrical)

N = number of screws

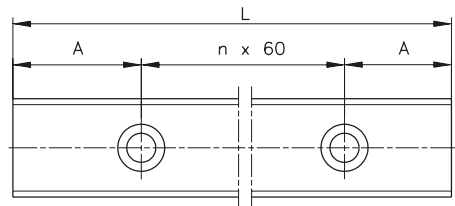

Guide Carriages

Guide carriage, normal
 KU 25.11

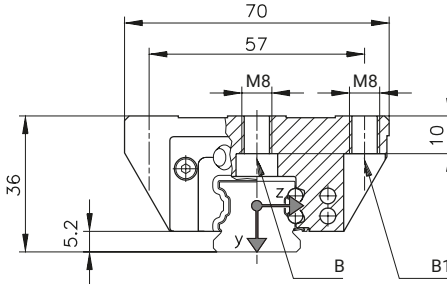

Guide carriage, narrow
 KU 25.13

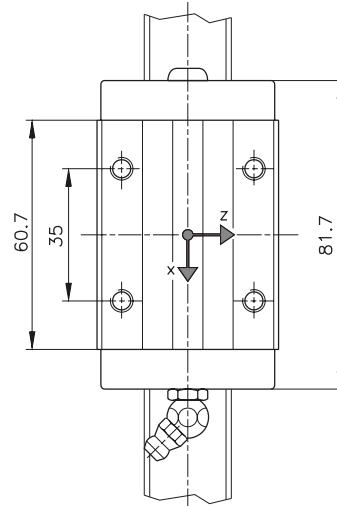
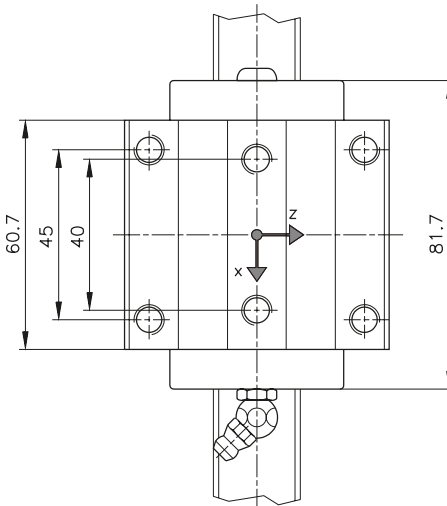
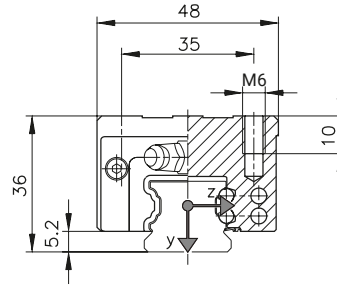

B= through-bore for screw M6 DIN 6912

B1= through-bore for screw M6 DIN EN ISO 4762

Load specifications

Item no.	Designation	F_{y0} [N]	F_{z0}^* [N]	M_{x0} [Nm]	M_{y0} [Nm]	M_{z0} [Nm]	C_0 [N]	C_0 [N]	m_{carriage} [kg]
K116041125	KU 25.11	7000	7000	75	75	75	37,000	17,900	0.71
K116041325	KU 25.13	7000	7000	75	75	75	37,000	17,900	0.56

*Lateral load without close fit,
 only frictional connection on design profile with screw 8.8 – reduced to 2000N

Recirculating Ball Bearing Guides

Recirculating Ball Bearing Guide KU 30.10

The track KU 30.10 must be combined into one unit with the guide carriages KU 30.11 and KU 30.13. However, they must be ordered individually.

The KU 30.10 track is especially suitable for Series 60.

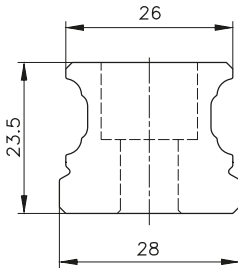
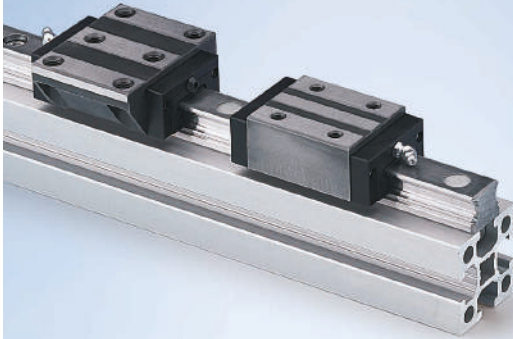

Track KU 30.10
K116041030

m = 4.3 kg/m

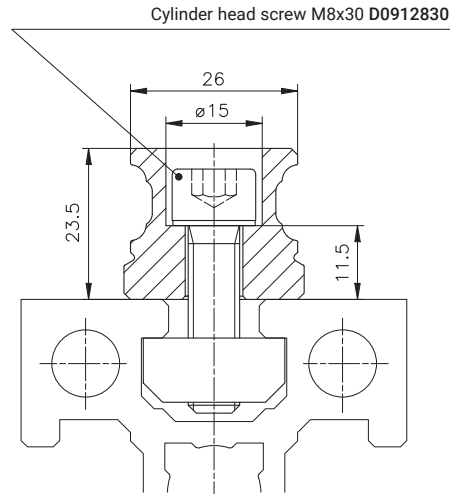

Track KU 30.10 with mounting elements
B51.04.406

Borehole spacing specifications

Support rail, L1 up to 2000 mm, single piece

Scope of application for A: $20 \leq A < 60$

$$N = \frac{L1 - (2 \times A)}{80} + 1 \text{ (+1 per joint)}$$

L1 = length of the support rail

A = distance from the first borehole to the profile edge (symmetrical)

N = number of screws

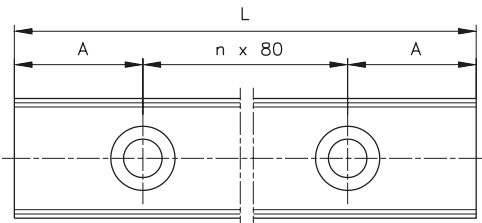

Guide Carriages

Guide carriage, normal
 KU 30.11

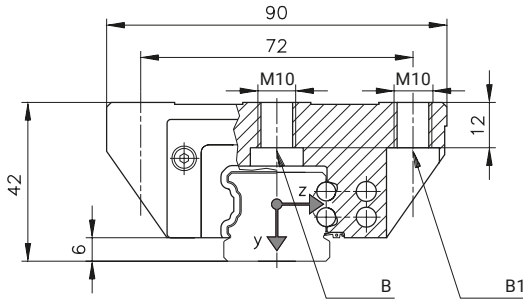

Guide carriage, narrow
 KU 30.13

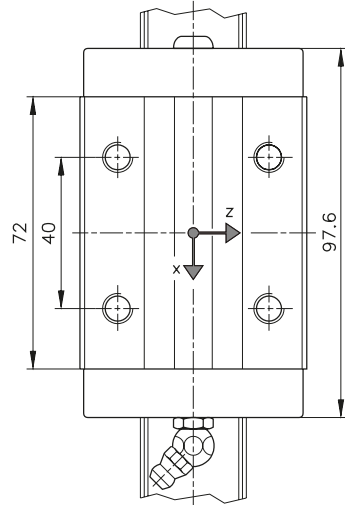
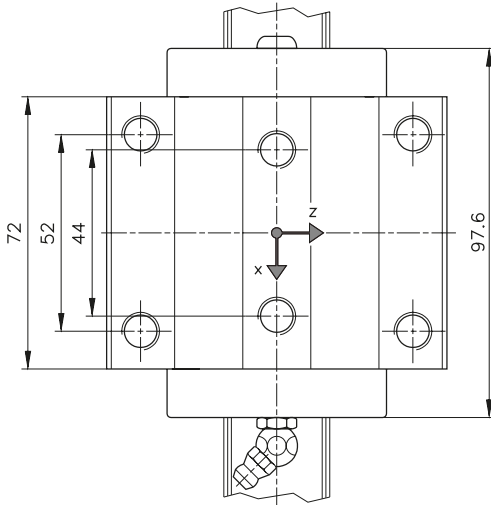
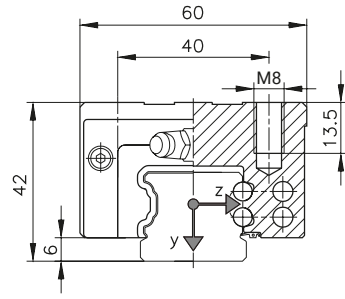

B= through-bore for screw M8 DIN 6912

B1= through-bore for screw M8 DIN EN ISO 4762

Load specifications

Item no.	Designation	F_{y0} [N]	F_{z0}^* [N]	M_{x0} [Nm]	M_{y0} [Nm]	M_{z0} [Nm]	C_0 [N]	C_0 [N]	m_{carriage} [kg]
K116041130	KU 30.11	10000	10000	140	140	140	55,000	27,500	1.4
K116041330	KU 30.13	10000	10000	140	140	140	55,000	27,500	1.09

*Lateral load without close fit,
 only frictional connection on structural profile with screw 8.8 – reduced to 3500N

Application Examples

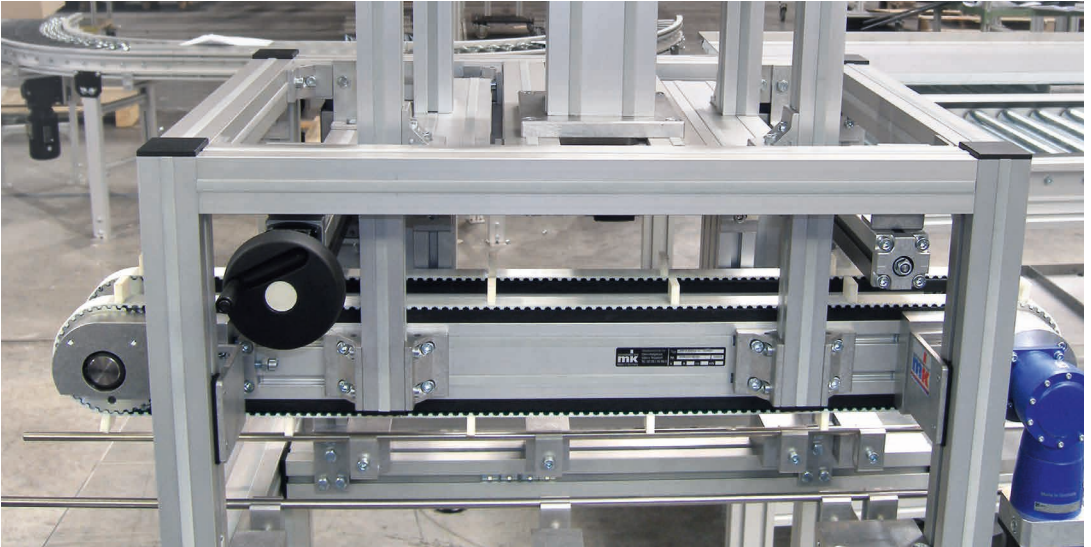

Dual VST 2015 with coupling via timing belts for width adjustment of the ZRF-P 2040.02 cycle conveyor



Dual VST 2015 with manual digital display for adjusting the stop bar



System 2015 adjusting units with handwheel and scale



Electromotive VST 2015 with recirculating ball bearing guide

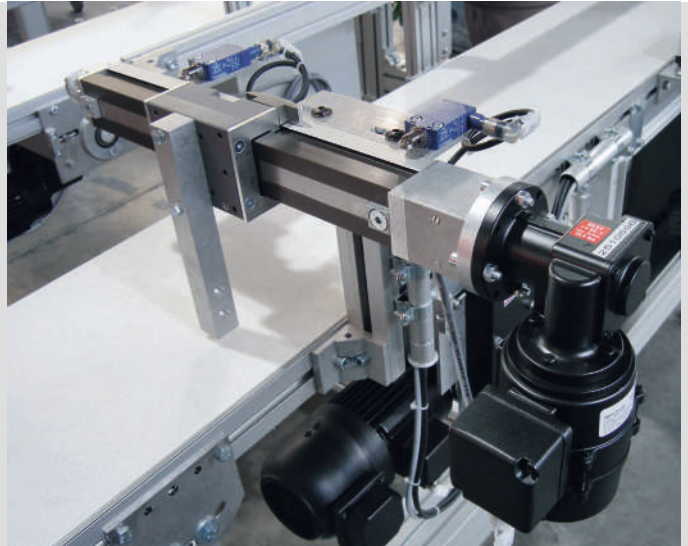

Dual electromotive VST 2015 for automatic width adjustment with scanning via safety limit switch

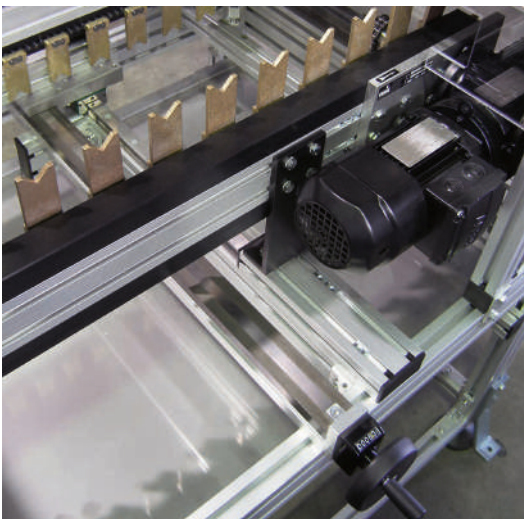

Dual VST 2015 with parallel recirculating ball bearing guide for supporting the load



Manual two-axis adjustment system for holding a marking device with VST 2015

Application Examples

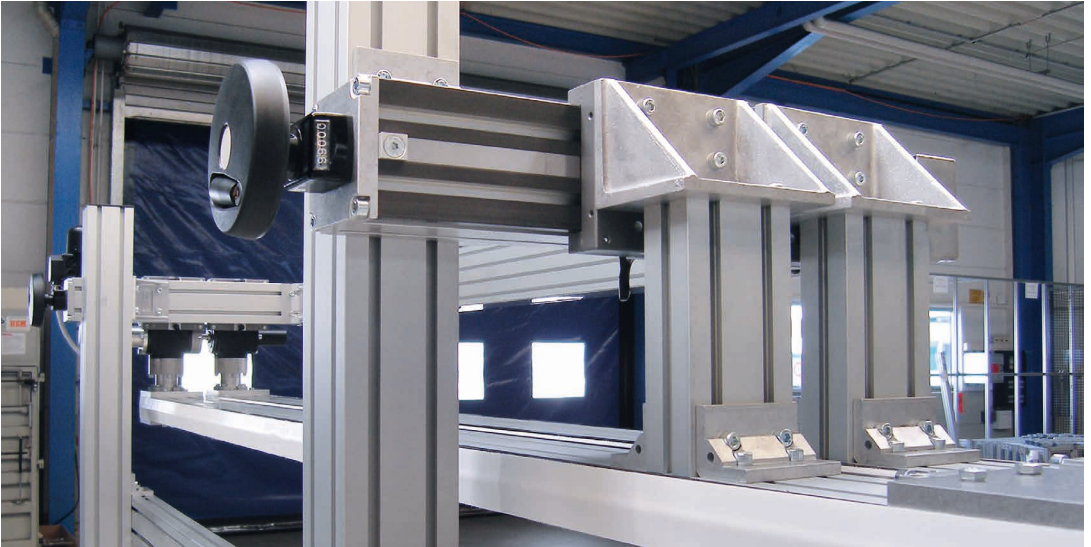

Dual VST 2011 for manual lane width adjustment on a side conveyor

11

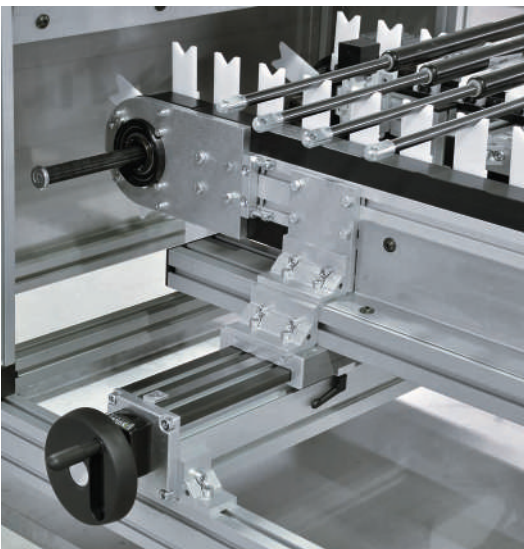

VST 2011 adjusting unit used for semi-automatic conveyor width adjustment in a chain conveyor system



Electromotive VST 2011 with custom measuring system on LZR 2005-38.44-30



VST 2011 with two counter-rotating slide carriages and digital display for adjusting the width of the pneumatic centring unit on the modular belt conveyor



VST 2011-H with handwheel as add-on kit for the belt conveyor with incline adjustment



System mk 2011 adjusting unit for brush cantilever

Application Examples

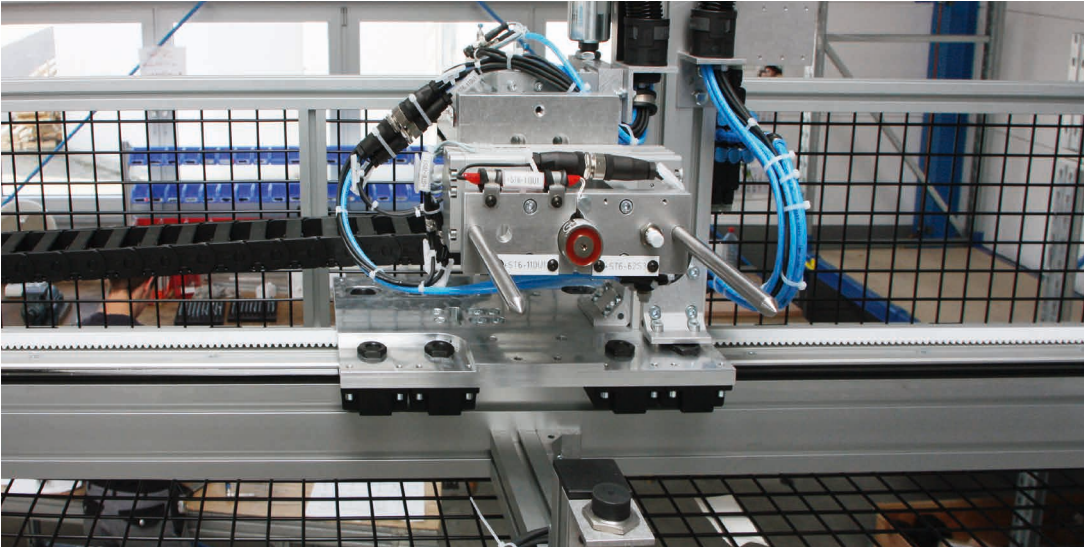

Horizontal slides comprised of linear module type LZR 2005-38.44-30 with fork grippers and swivel unit for moving and emptying workpiece baskets

11



Linear module type LZR 2005-38.44-30 as a direct length measuring system with measuring head on the roller carriage

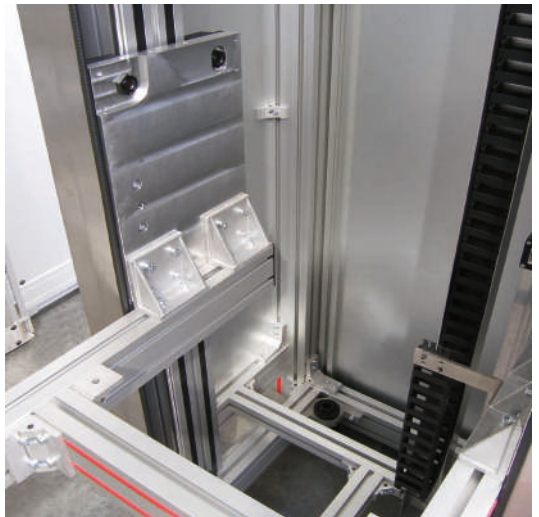

Double-LZR 2005-38.44-30 with side mounted carriage plate and cantilever for conveyor as lift



Pneumatic linear module with PF 38.77 and LW 38.77-44 as a transfer unit with 10 vacuum suction grippers

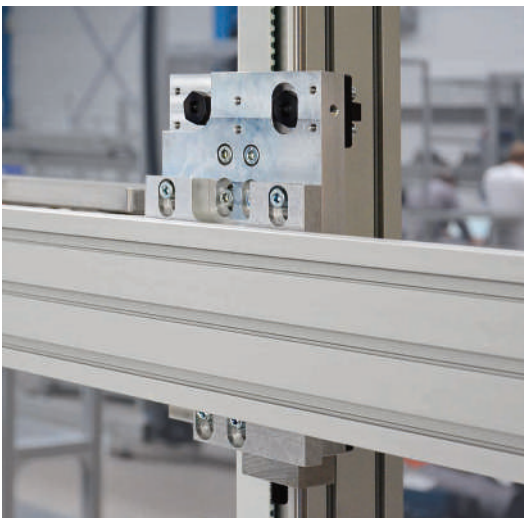

Linear unit LZR 2004-38.41-30 as a height adjustment unit for an assembly and testing workstation

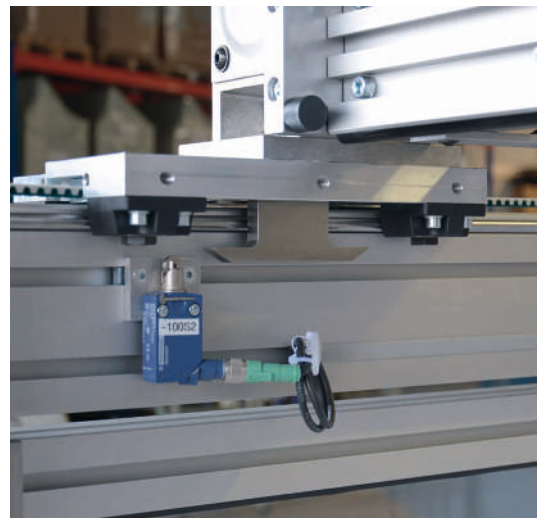

Linear unit LZR 2004-38.41-30 drive coupled via a slip clutch

Application Examples

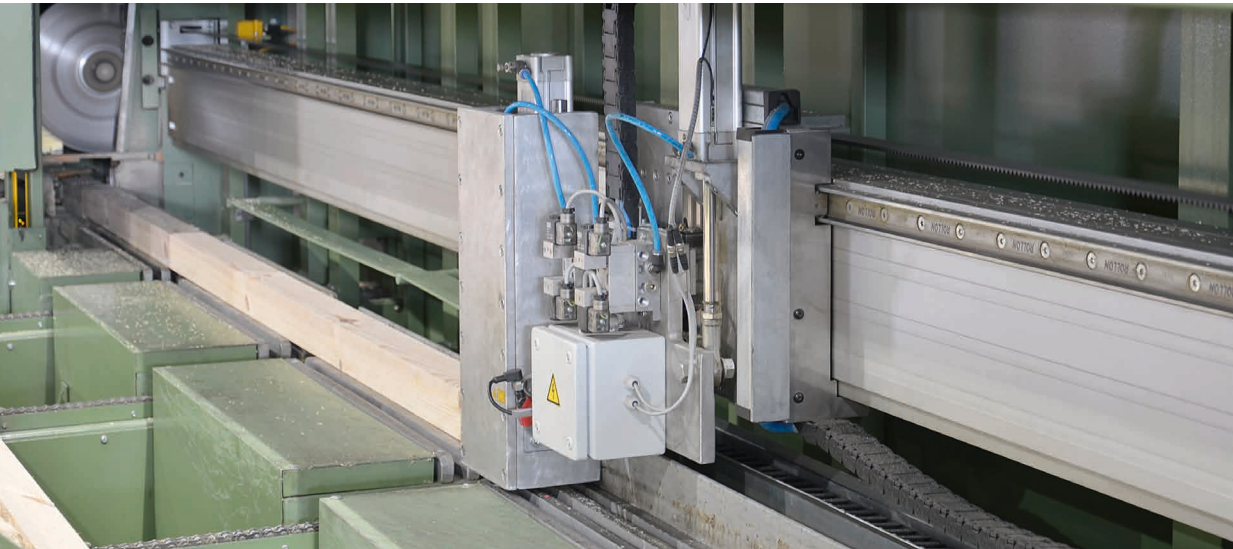

LZR Series 60 linear module based on the mk 2060.07 profile with track rollers and rails from Rollon

11

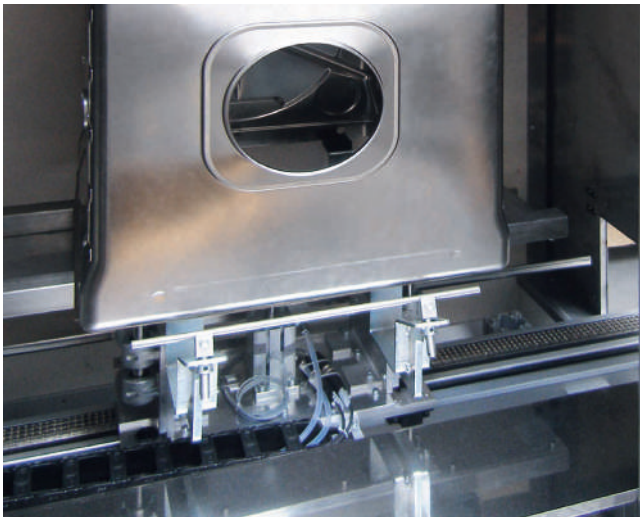

Linear module with chain for HT range and in ESD version Product intake with pneumatic lift for lifting/depositing before, in and after the oven

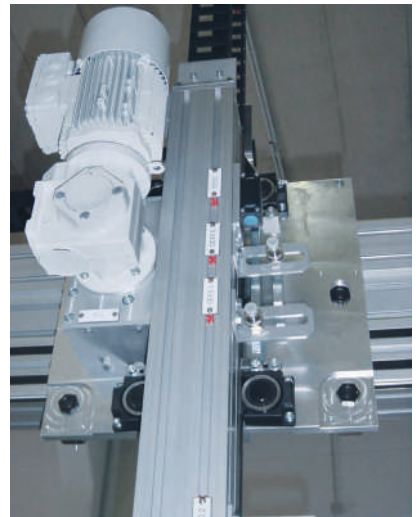

Gantry with LZR 2005 on foamed combined profile Roller carriage with support rollers as cross-carriage with LZR 2005 and Omega drive as X-Z surface gantry



Base LZR 2005-38.44-30 with side roller carriage on foamed combined profile as gantry, with support rollers for torque loads and manual VST 2011 as Z axis

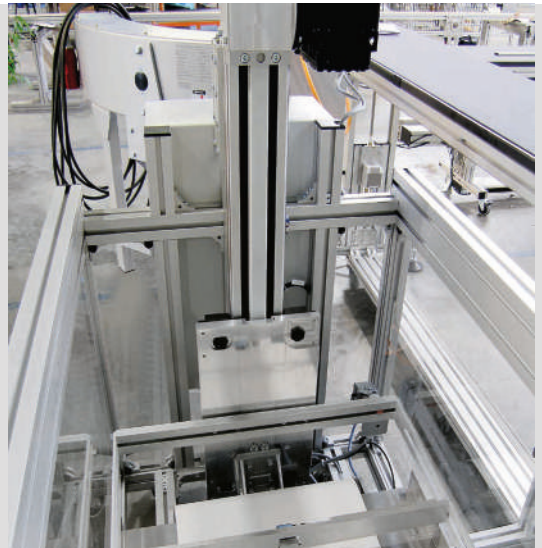

Linear module type LZR 2005-38.44-30 with motor and controller as a lift with a belt conveyor



Linear module type LZR 2004-38.41-30 with absolute value rotary encoder mounted on the tail

Application Examples



Dual LZR 2005-38.44 with cantilever for dual ZRF-P 2010 for lift and transfer from a dual ZRF-P as a lift-and-transfer module

11



Dual-axis linear module comprising LZR 2011-38.44.30 with side mounted carriage plate

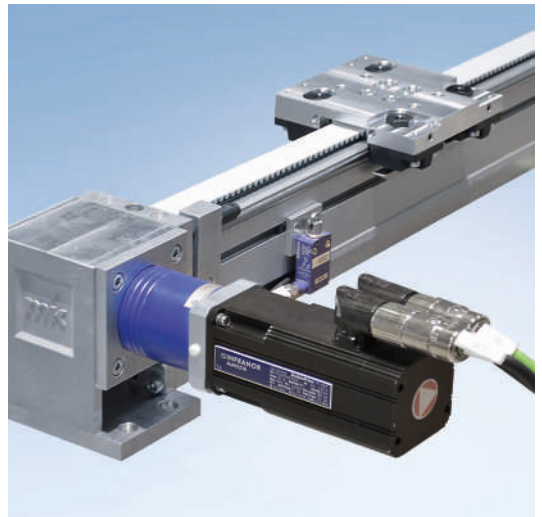

LZR 2004-38.41-30 with servo gearmotor from Infranor



Dual LZR 2005 as lift in steel rack



Dual linear module type LZR 2005-38.44-30 with cantilever for conveyor as a lifting unit

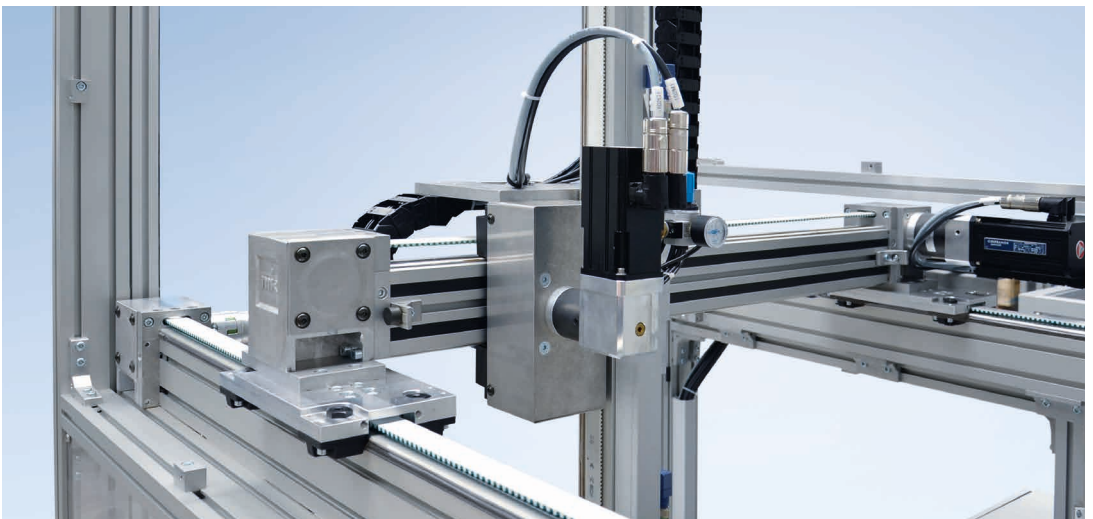

Three-axis gantry with driven linear modules, gripper and controller

Application Examples



Two-dimensional gantry with vacuum gripper as a handling and loading system for steel. Two independent loading systems on a common X axis with gear rack with track rollers and riding rack drive

11



X-Z gantry with gripper for transferring crankshafts. X axis as LZR with support roller and timing belts, Z axis with timing belt Omega drive and fall arrest

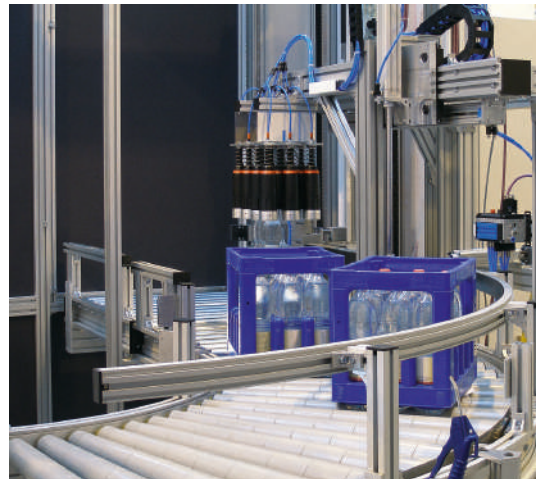

X-Z axis combination with pneumatic drive and vacuum grippers for loading and unloading beverage crates



Gantry stand with telescopic gripper unit



Horizontal axis with foamed combined profile for reinforcement



Lift for storage system

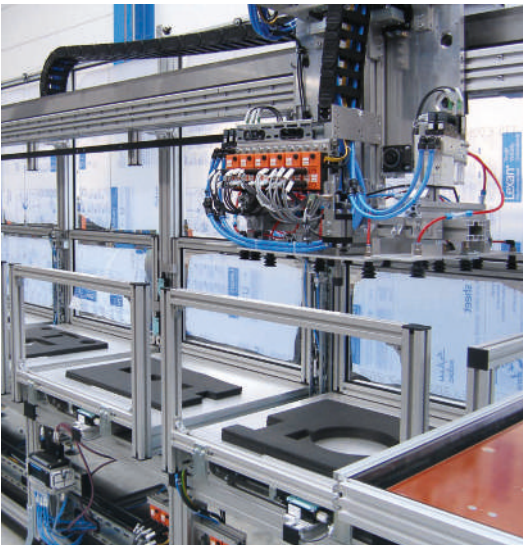

X-Z gantry with additional pneumatic weight balancing as a holder for a vacuum gripping system



Short stroke lift based on PF-38.44 linear guide system

Application Examples



Lift station for lifting and lowering conveyors on two conveyor levels. Cross-conveyor unit with recirculating ball bearing guides positioned horizontally in the frame



Recirculating ball bearing guide for manual lane width adjustment and for clamping the pneumatic centring device and electromotive rotating unit



Lifting unit with KU 25 recirculating ball bearing guide and angle bracket

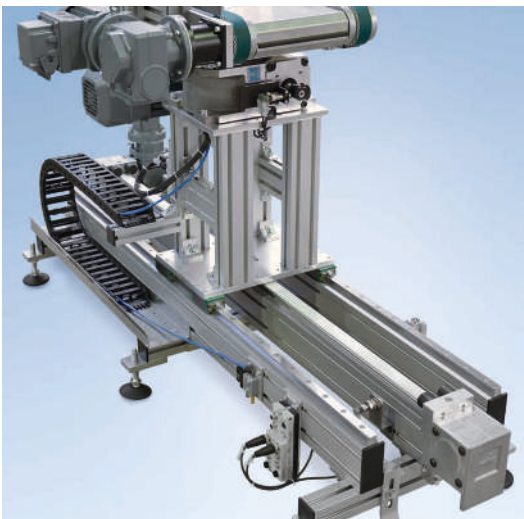

Shuttle system with rotary indexing table for pallet transport, guided via a double linear axis with recirculating ball bearing guide



Frame for stress testing based on KU 30.10 recirculating ball bearing guide

Application Examples



Gantry for handling sleeves. The X axis is moved by a dual linear module with a KU 30.30 recirculating ball bearing guide

11

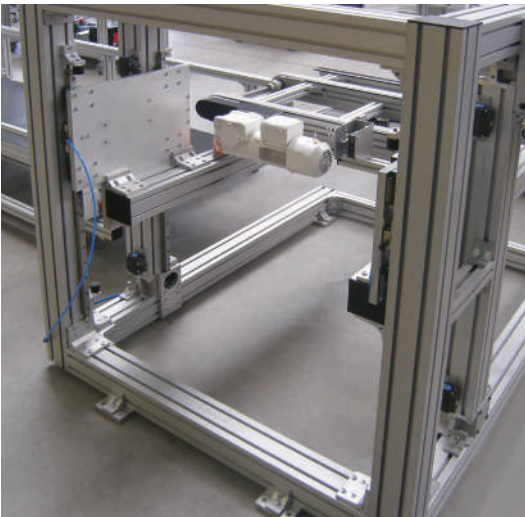

Lifting unit with LZR with recirculating ball bearing guide KU 25 with profile cantilever for supporting the ZRF-P 2010 conveyor



Two-track feed for machine loading. The separator can be adjusted for various diameters using a recirculating ball bearing guide

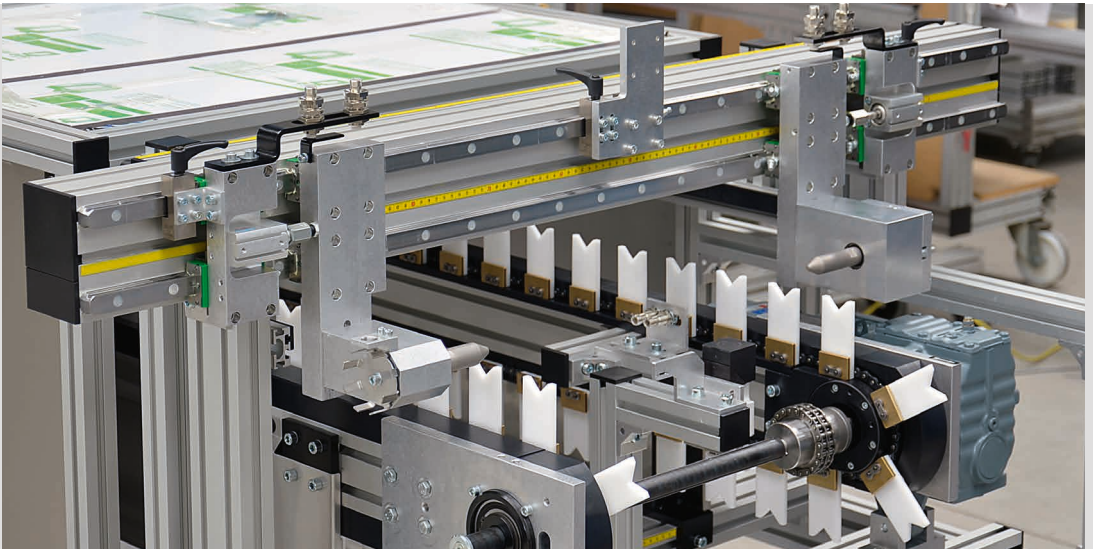

Timing chain conveyor with alignment unit for camshafts using recirculating ball bearing guide



Transfer shuttle with pallet carriers, carriage with recirculating ball bearing guide

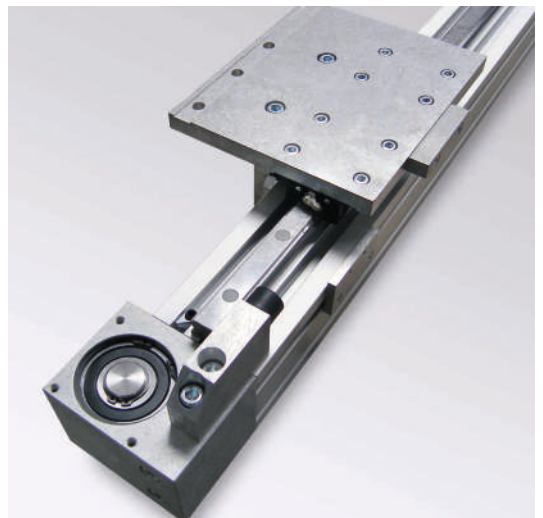

LZR with recirculating ball bearing guide

Chapter 12 Application Examples of System Solutions

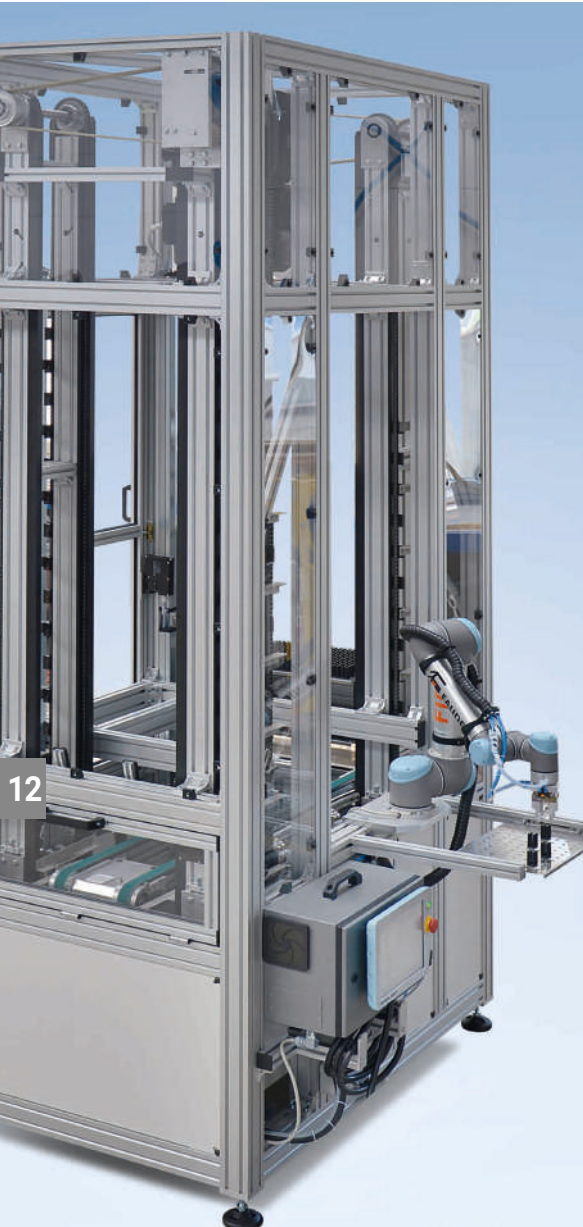

» System solutions for transferring, interlinking and handling. «

mk transfer and handling systems provide you with reliable and practical system solutions. Designed according to your needs, we optimise your manufacturing and assembly processes.

Standardised transfer systems

Versamove is a transfer system for transporting pallets that can be optimally tailored to the customer's specific requirements. Divided into three weight and size classes, it always has the right system for any application. With its modular construction and compatibility with other systems on the market, it can be used for a broad range of applications.

The **SPU 2040** accumulating pallet recirculation system with automatic pallet return is suitable for cost-effective interlinking, feeding, buffering, positioning and separation of workpieces in the tightest of spaces. Pallets are transported from above and then conveyed back suspended below the transport level once the workpieces have been removed.

The robust **TKU 2040** chain conveyor system with optional adjustable width for various workpieces is especially well suited for cycled, defined and position-oriented supply and removal as well as for interlinking machines and machining centres.

Handling Systems

mk handling systems are built from our linear technology components as standard. Examples include multi-axis gantry systems with linear modules and custom grippers. They can be used as pick-and-place units in combination with transfer systems, or they can be used as a standalone solution.

versa *move*

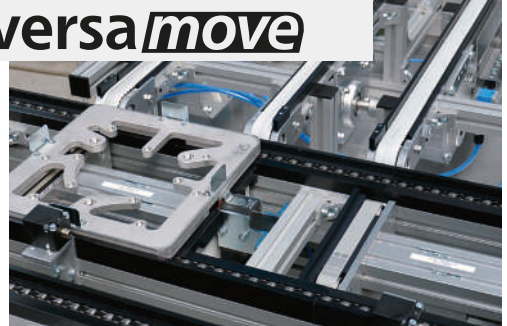

Benefits of mk System Solutions

- Efficient solutions for conveying, feeding, interlinking, sorting, buffering, separating, rotating, loading and unloading
- Based on our proven construction kit of profile, conveyor and linear technology
- Planning, design, assembly and start-up of turnkey systems
- Maintenance and service agreements with choice of various response times
- Locations worldwide for local support
- Guaranteed supply of spare parts from reputable international suppliers
- Extensive industry references in the automotive, electrical, food, pharmaceutical, home appliance, machine tool, packaging and plastics industries

SPU 2040



TKU 2040

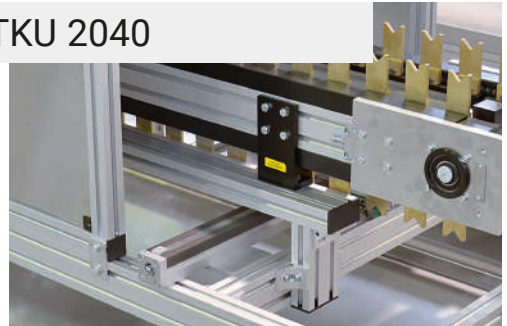

Handling Systems



Application Examples **versa***move*



Versamove standard pallet circulation system with FPF-P 2045 curved flat top chain conveyor and custom workpiece holder

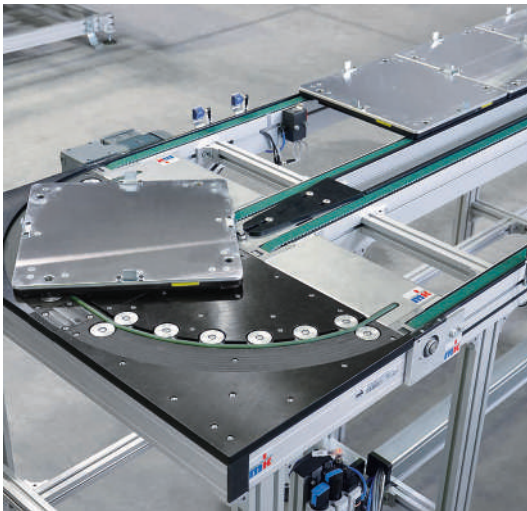

Versamove standard pallet circulation system with compact 180° KER 320 curved section



Versamove plus turnkey pallet system in assembly automation

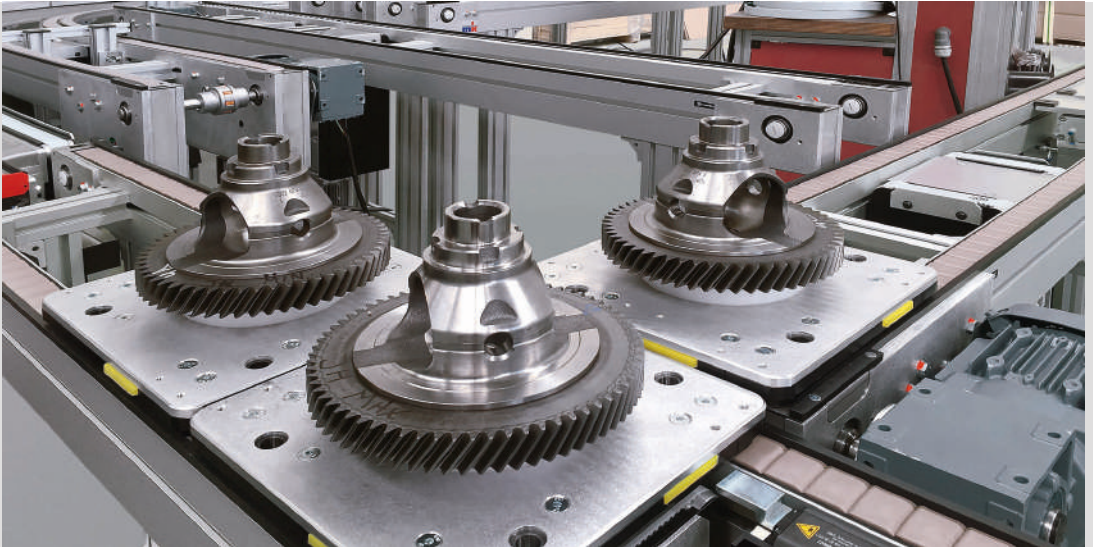

Versamove standard with flat top chain conveyor
and lift-and-transfer conveyors



Lift-and-transfer conveyor with
coupled drive and central stroke unit for
bridging very short transverse sections

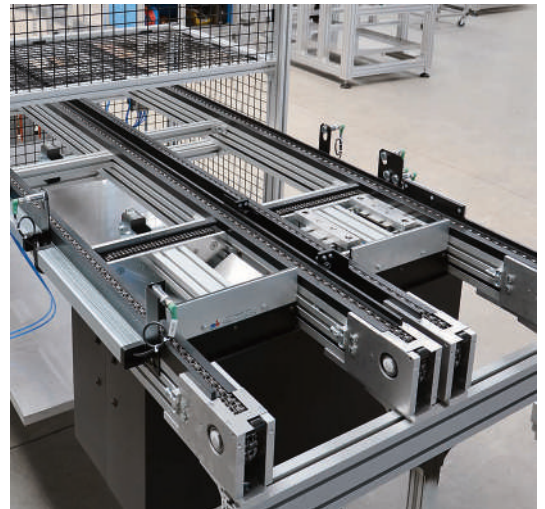

Lift-and-transfer conveyor with chain
and coupled drive for the automatic removal of
products with indexing from below

Application Examples **versa***move*



Separation of pallets from the main line in two parallel cross conveyor tracks



Electrically driven lift in "stand-alone" frame with guarding



Lift that is accessible from three sides, with rotating assembly in the lift carriage and feed via a Versamove ultra



Versamove plus with large custom pallets



Lift-and-transfer conveyor in parallel arrangement with support roller for bridging small gaps

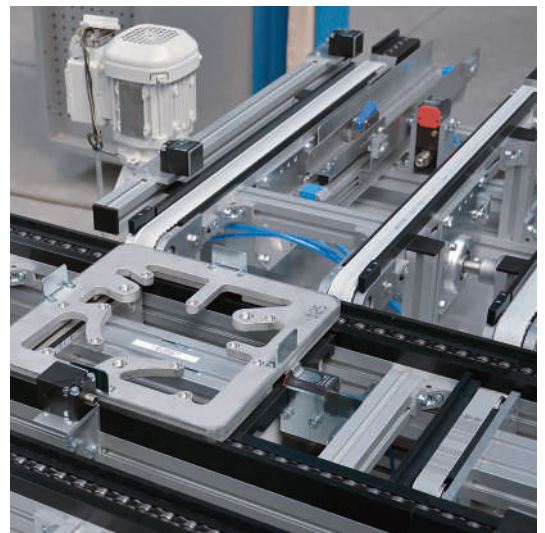

Versamove plus with custom pallet

Application Examples for SPU 2040



SPU accumulating pallet circulation system with pallet separation function as a feed for parts for a production system

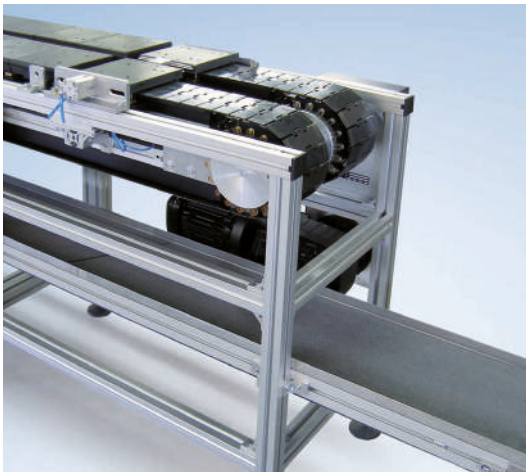

Interlink of dual-line pallet circulation system with GUF-P 2000 belt conveyor as a discharge conveyor for faulty parts

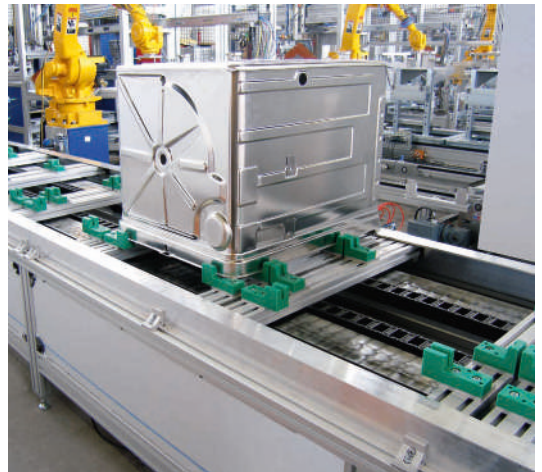

SPU double-line as an infeed conveyor for dishwasher housings

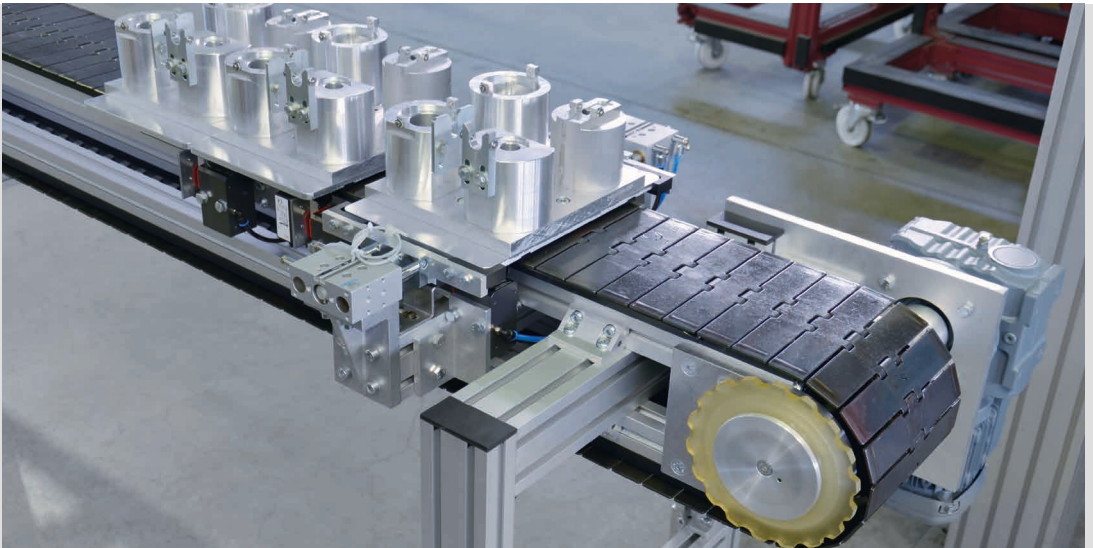

SPU with separator function for loading by hand and removal by robot

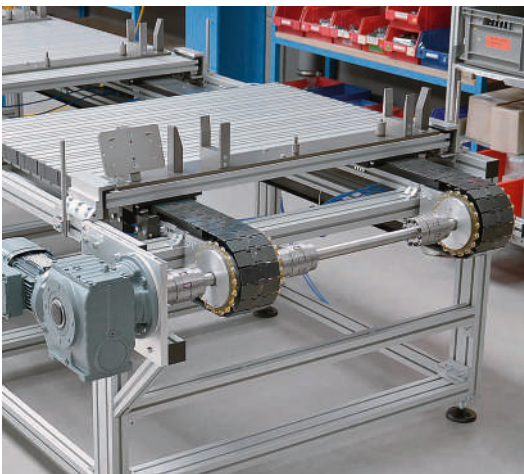

SPU double-line 114 system with custom pallet



Single-line SPU with custom pallet holder

Application Examples for TKU 2040

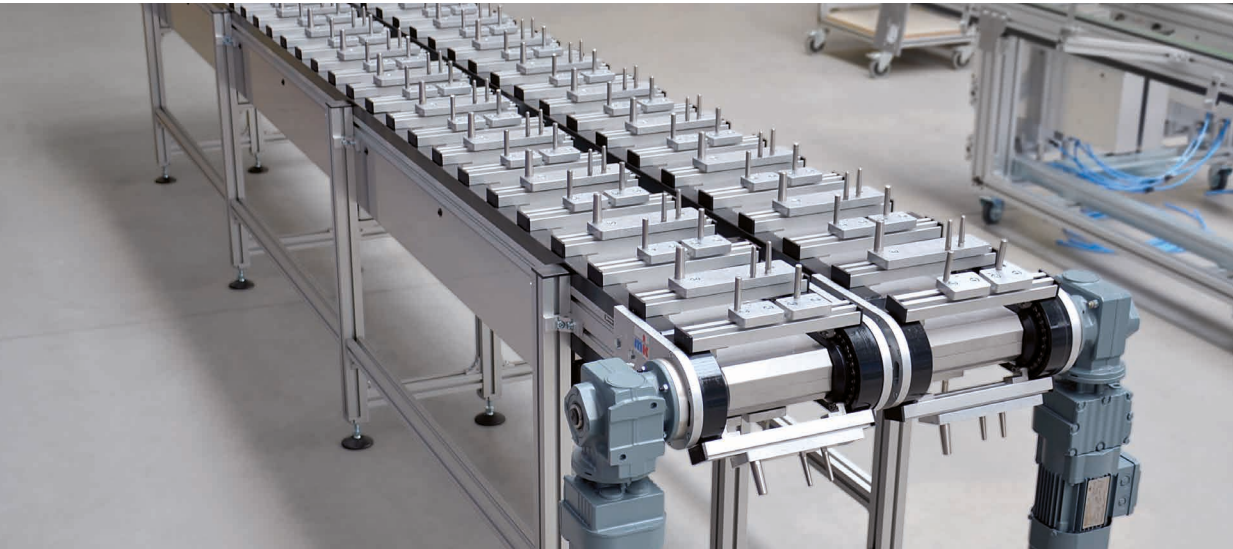

TKU as dual-line system with custom profile pallets and holders



TKU 2040 with special adjusting unit for adjusting the distance between the conveyor chains

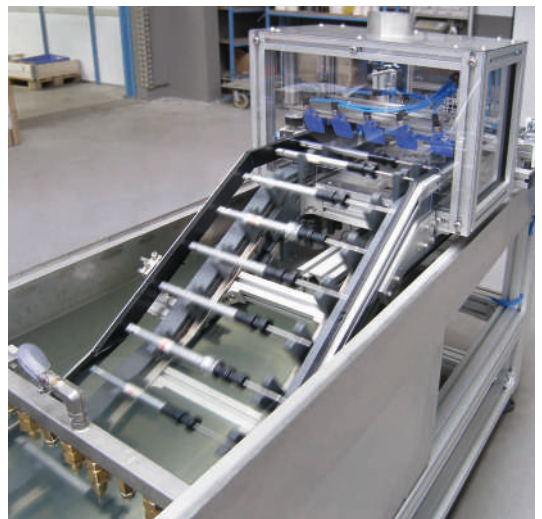

TKU 2040 with 20° inclination and transport of workpieces through a cleansing bath

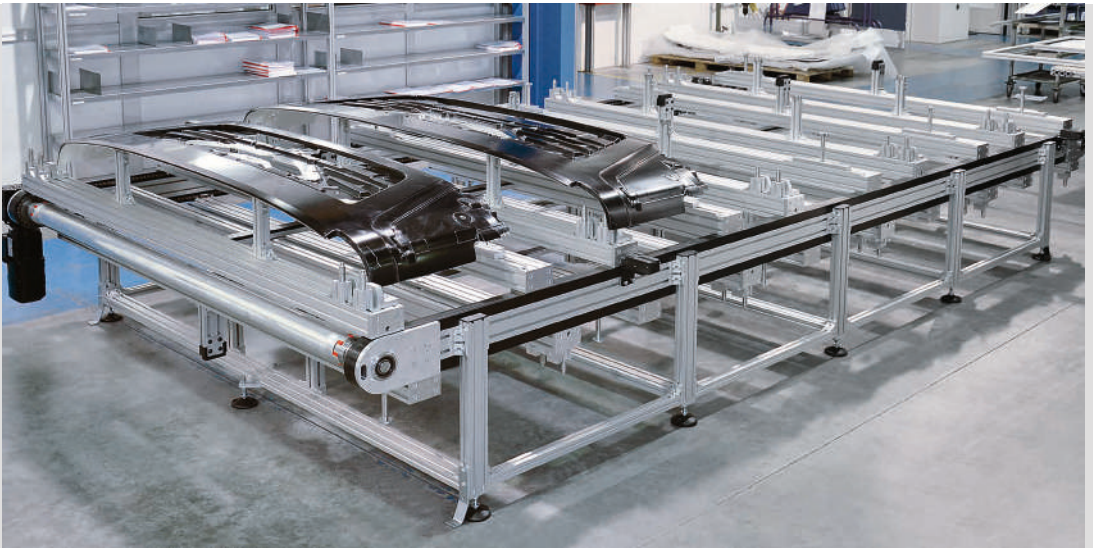

TKU 2040 indexing chain conveyor system with custom workpiece holder and centring system for the automotive industry

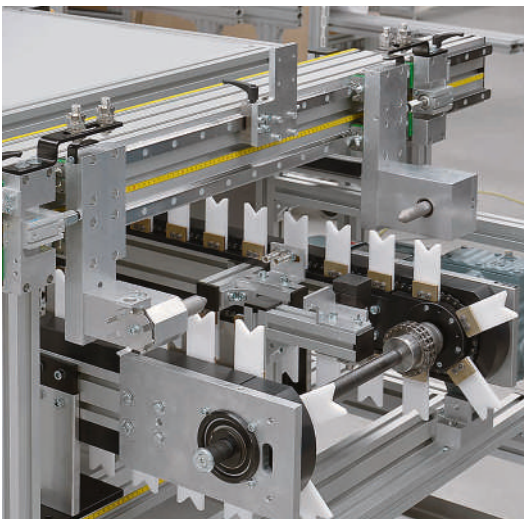

TKU 2040 for transporting camshafts with positioning sensors

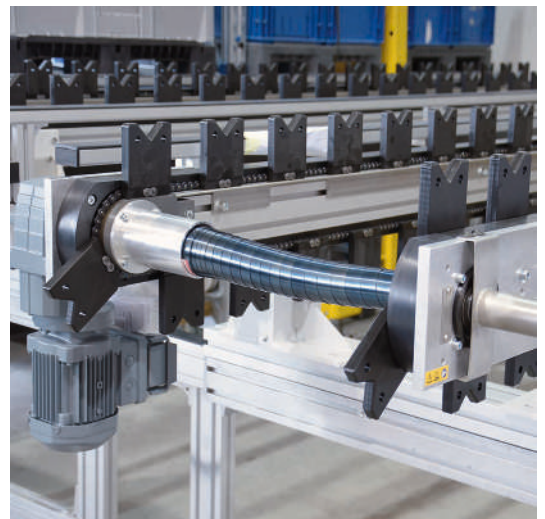

TKU 2040 for transporting camshafts with a spiralled cover as a protective guard on the connecting shaft

Application Examples for Handling Systems



Pivoting conveyor system with integrated slug clamping, that picks off and clamps blow moulded parts on the machine and transports them away.



Modu-Con circulation system – the transport medium is a 3/4" vertical hollow pin chain arranged between the wear strips



System for filling boxes with interlinking of an upstream tube filling station and integration of the provided scale with a discharge for defective boxes.

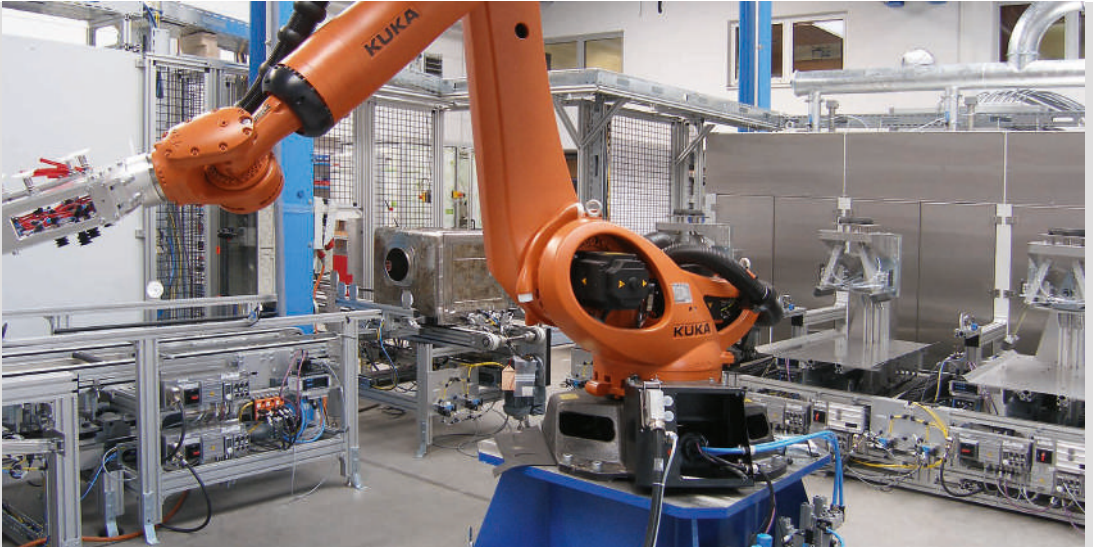

Turnkey interlink system, including controller and protective device guard with integrated robot island and melting ovens

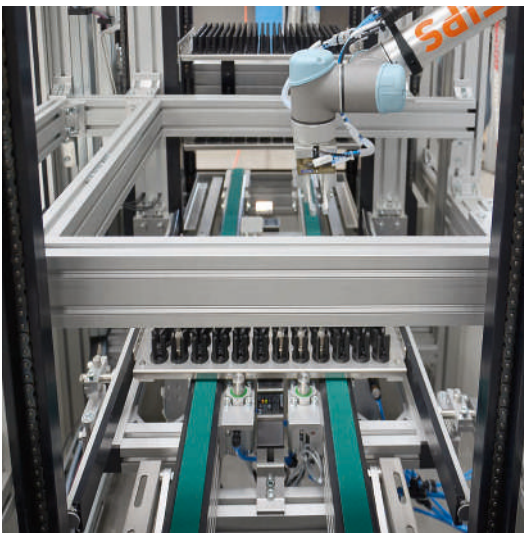

The pallet is transported in and out of a production cell through a double-line timing belt conveyor



Production cell with paternoster storage for infed and discharged parts

Application Examples for Handling Systems



Handling and loading system for large parts

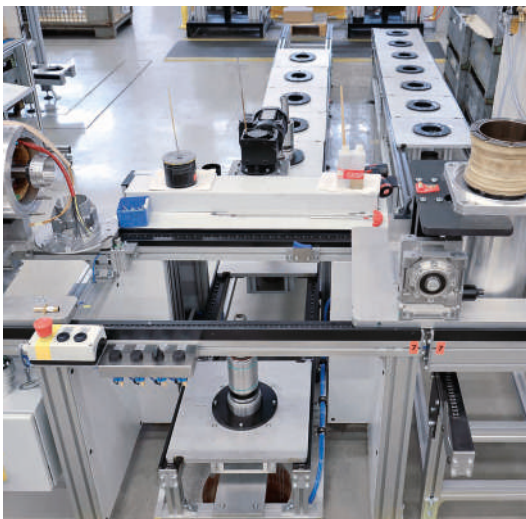

Marriage station for two production lines

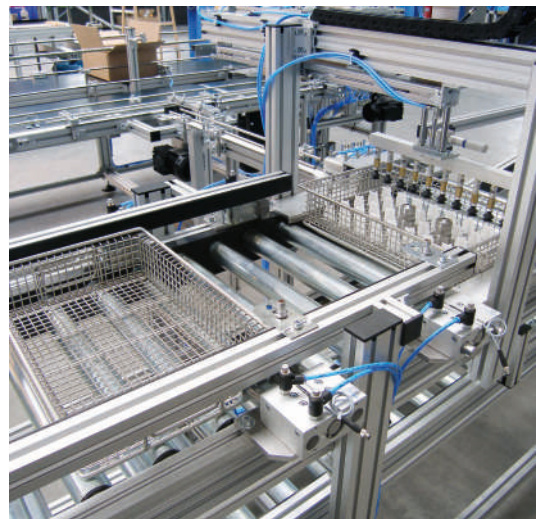

Transport in and out for a customer's measuring and packaging unit



Automated interlink with pallets, including rotating, stopping, separating and centring, based on flat top chain conveyor



RBT-P 2255 roller conveyor as a storage conveyor with central loading and unloading tasks



XYZ handling gantry for stacking and unstacking product pallets and euro pallets

Index – By Search Terms

Accessories, chain conveyors	216	Chain conveyors; application examples	220
Accessories, drip pan	305	Chain conveyors; pallets	216
Accessories, end stop	304	Chains	214
Accessories, timing belt conveyors	172	Chains for KTF-P 2010	214
Accumulating roller chain conveyor SRF-P 2010	196	Chains for SRF-P 2010 and SRF-P 2012	215
Accumulating roller chain conveyor SRF-P 2012	206	Chapter on belt conveyors	18
Adapter profiles	348	Chapter on chain conveyors	182
Adjustable side rails	295	Chapter on conveyor technology accessories	278
Adjusting units VST 2011	328	Chapter on flat top chain conveyors	226
Adjusting units VST 2015	324	Chapter on linear units and modules	318
Application examples for belt conveyors	96	Chapter on modular belt conveyors	116
Application examples for chain conveyors	220	Chapter on notes on linear technology	314
Application examples for conveyor technology accessories	306	Chapter on roller conveyors	244
Application examples for flat top chain conveyors	238	Chapter on rotary tables	272
Application examples for handling systems	418	Chapter on system solutions	408
Application examples for linear technology	392	Chapter on timing belt conveyors	152
Application examples for linear units and modules	392	Clamping profiles	346
Application examples for modular belt conveyors	146	Cleats and side walls	92
Application examples for roller conveyors	266	Configuration SBF-P 2254	230
Application examples for rotary tables	276	Conveyor stand fastening elements, stands	280
Application examples for SPU 2040	414	Conveyor technology accessories	278
Application examples for timing belt conveyors	176	Conveyor technology accessories; application examples	306
Application examples for TKU 2040	416	Conveyor technology configurator	16
Application examples for Versamove	410	Curved belt conveyor KGF-P 2040	80
Assembly aid for chain replacement	217	Curved modular belt conveyor KMF-P 2040	130
Belt conveyor, GUF-P 2000	36	Curved section, RBM-P 2255	263
Belt conveyor, GUF-P 2004	62	Curved section, RBS-P 2065/2066	251
Belt conveyor, GUF-P 2041	52	Curved section, RBS-P 2255	255
Belt conveyor, GUF-P 2045	32	Curved section, RBT-P 2255	259
Belt conveyor, GUF-P MINI	22	DGF-P 2001	84
Belt conveyor; application examples	96	DGF-P 2001; drive version AC	86
Belt conveyor; cleats and side walls	92	DGF-P 2001; pallet	87
Belt conveyors	18	Double belt conveyor DGF-P 2001	84
Belts	88	Drip pan	305
Benefits of mk conveyor technology	6	Drive roller conveyor RBM-P 2255	260
Benefits of mk linear technology	314	Drive roller conveyor, curved section; RBM-P 2255	263
Chain conveyor maintenance kit	217	Drive roller conveyor, RBM-P 2255	260
Chain conveyor, KTF-P 2010	186	Drive roller conveyor, straight section; RBM-P 2255	262
Chain conveyors	182	DTZ-P 2040, rotary table	274
Chain conveyors; accessories	216	Electrical components	302
		End stops	304
		Features of mk track roller assemblies	334
		Fixed side rails	294
		Flat top chain conveyor	226

Flat top chain conveyor; application examples	238	GUF-P MINI; drive version AG	27
Flat top chain conveyor; modular overview	231	GUF-P MINI; drive version BA	28
Flat top chains, SBF-P 2254	234	GUF-P MINI; drive version BC	29
Floor fastening element for single stand	283	GUF-P MINI; tails	29
Gliding assemblies	320	Guide rods	351
Gravity roller conveyor RBS-P 2065/2066	248	Guide rollers	350
Gravity roller conveyor RBS-P 2255	252	Handling systems; application examples	418
Gravity roller conveyor, curve; RBS-P 2066	251	Head drives, DGF-P 2001	86
Gravity roller conveyor, curve; RBS-P 2255	255	Head drives, GUF-P 2000	38
Gravity roller conveyor, straight section;		Head drives, GUF-P 2004	64
-RBS-P 2065/2066	250	Head drives, GUF-P 2041	54
Gravity roller conveyor, straight section;		Head drives, GUF-P MINI	24
-RBS-P 2255	254	Head drives, KFG-P 2000	72
GUF-P 2000, belt conveyor	36	Head drives, KFM-P 2040	126
GUF-P 2000; drive version AA	38	Head drives, KFS-P 2040.86	138
GUF-P 2000; drive version AC	39	Head drives, KMF-P 2040	134
GUF-P 2000; drive version AF	40	Head drives, KTF-P 2010	188
GUF-P 2000; drive version AG	41	Head drives, MBF-P 2040	122
GUF-P 2000; drive version AM	42	Head drives, SRF-P 2010	198
GUF-P 2000; drive version AS	43	Head drives, SRF-P 2012	208
GUF-P 2000; drive version AU	44	Head drives, ZRF-P 2010	162
GUF-P 2000; drive version BA	45	Head drives, ZRF-P 2040	158
GUF-P 2000; drive version BC	46	Hinged plate belts	145
GUF-P 2000; drive version BF	47	Incline conveyor belt	70
GUF-P 2000; drive version CA	48	Incline conveyor hinged plate belt	136
GUF-P 2000; tails	49	Incline conveyor modular belt	124
GUF-P 2004, belt conveyor	62	Individual components of side rails	297
GUF-P 2004; drive version AA	64	Individual components of	
GUF-P 2004; drive version AC	65	track roller assemblies	346
GUF-P 2004; drive version AM	66	Initiators	303
GUF-P 2004; drive version AS	67	Internal drive, GUF-P 2045	34
GUF-P 2004; tails	68	Internal drives, GUF-P 2000	48
GUF-P 2041, belt conveyor	52	Internal drives, GUF-P 2041	59
GUF-P 2041; drive version AA	54	KFG-P 2000 ECO; variants	77
GUF-P 2041; drive version AC	55	KFG-P 2000, incline conveyor belt	70
GUF-P 2041; drive version AF	56	KFG-P 2000; drive version AC	72
GUF-P 2041; drive version AS	57	KFG-P 2000; drive version AF	73
GUF-P 2041; drive version BC	58	KFG-P 2000; drive version AS	74
GUF-P 2041; drive version CA	59	KFG-P 2000; drive version AU	75
GUF-P 2041; tails	60	KFG-P 2000; side rail	79
GUF-P 2045, belt conveyor	32	KFG-P 2000; stand type ECO	78
GUF-P 2045; drive version CA	34	KFG-P 2040, incline conveyor modular belt	124
GUF-P 2045; tails	35	KFM-P 2040; drive version AC	126
GUF-P MINI, belt conveyor	22	KFM-P 2040; drive version AS	127
GUF-P MINI; drive version AA	24	KFM-P 2040; stands	128
GUF-P MINI; drive version AC	25	KFS-P 2040.86, incline conveyor	
GUF-P MINI; drive version AD	26	hinged plate belt	136

Index – By Search Terms

KFS-P 2040.86; drive version AC	138	Modular belts	142
KFS-P 2040.86; drive version AS	139	Modular belts for KFS-P 2040.86	145
KFS-P 2040.86; side rails	141	Modular belts for KMF-P 2040	144
KFS-P 2040.86; stands	140	Modular belts for MBF-P 2040	142
KGF-P 2040, curved belt conveyor	80	Modular overview, SBF-P 2254	231
KGF-P 2040; drive version BC	82	Mounting profiles	336
KGF-P 2040; stands	83	Notes on conveyor technology	6
KMF-P 2040, curved modular belt conveyor	130	Notes on linear technology	314
KMF-P 2040; drive versions	134	Nuts	300
KMF-P 2040; properties	132	Retrofit nuts	301
KMF-P 2040; variants	133	Other accessories	304
KTF-P 2010	186	Other conveyor technology accessories	304
KTF-P 2010; drive version AA	188	Pad options	281
KTF-P 2010; drive version AC	189	Pallets, chain conveyors	216
KTF-P 2010; drive version AF	190	Pallets, DGF-P 2001	87
KTF-P 2010; drive version AS	191	Pallets, timing belt conveyors	172
KTF-P 2010; drive version BC	192	Profile guide PF 10-38.31/55	358
KTF-P 2010; drive version BF	193	Profile guide PF 10-38.32/56	360
KTF-P 2010; wear strips	194	Profile guide PF 10-38.41/60	368
Line RBM-P 2255	262	Profile guide PF 10-38.77 (internal)	366
Line RBS-P 2065/2066	250	Profile guide PF 16-38.33/56	362
Line RBS-P 2255	254	Profile guide PF 16-38.36	372
Line RBT-P 2255	258	Profile guide PF 16-38.44/61	370
Linear modules, LZR	374	Profile guide PF 6-38.20/50	352
Linear technology; application examples	392	Profile guide PF 6-38.21	354
Linear units	352	Profile guide PF 6-38.30/55	356
Linear units and modules	318	Profile guide PF 6-38.75 (internal)	364
Linear units and modules; application examples	392	QuickDesigner – the conveyor technology configurator	16
Lower belt drives, GUF-P 2000	45	RBM-P 2255, drive roller conveyor, curved section	262
Lower belt drives, GUF-P 2041	58	RBM-P 2255, drive roller conveyor, straight section	282
Lower belt drives, GUF-P MINI	28	RBM-P 2255, roller conveyor, drive roller	260
Lower belt drives, KGF-P 2040	82	RBS-P 2065/2066, gravity roller conveyor	248
Lower belt drives, ZRF-P 2010	166	RBS-P 2065/2066, gravity roller conveyor, straight section	250
Lower run drives, KTF-P 2010	192	RBS-P 2066, gravity roller conveyor, curved section	251
Lower run drives, SRF-P 2010	202	RBS-P 2255, gravity roller conveyor	252
Lower run drives, SRF-P 2012	211	RBS-P 2255, gravity roller conveyor, curved section	255
LZR 2000-38.41-15, linear module	376	RBS-P 2255, gravity roller conveyor, straight section	254
LZR 2004-38.41-30, linear module	378	RBS-P 2255, tangential chain roller conveyor	256
LZR 2005-38.44-30, linear module	380	RBT-P 2255, tangential chain roller conveyor, curved section	259
LZR 2011-38.44-30, linear module	382		
MBF-P 2040, modular belt conveyor	120		
MBF-P 2040; drive version AC	122		
MBF-P 2040; drive version AS	123		
Modular belt conveyors	116		
Modular belt conveyors, MBF-P 2040	120		
Modular belt conveyors; application examples	146		

RBT-P 2255, tangential chain roller conveyor, straight section	258	SRF-P 2012; drive version BC	211
Recirculating ball bearing 25	388	SRF-P 2012; drive version BF	212
Recirculating ball bearing 30	390	SRF-P 2012; wear strips	213
Recirculating ball bearing guide KU 25.10	388	Stand versions and conveyor stand fastening elements	280
Recirculating ball bearing guide KU 30.10	390	Stand, heavy-duty	293
Recirculating ball bearing guides	384	Stand, KFG-P 2000	78
Reglomats	302	Stand, KFM-P 2040	128
Roller conveyors	244	Stand, KFS-P 2040.86	140
Roller conveyors; application examples	266	Stand, KGF-P 2040	83
Rollers	264	Stand, lightweight	285
Rotary table DTZ-P 2040	274	Stand, medium-weight	289
Rotary tables; application examples	276	Stand; conveyor stand fastening elements	280
SBF-EMMA, flat top chain conveyor	236	Stand; pad options	281
SBF-P 2254; drive version AC	228	Stand; version 31	293
SD – stopper damped chain conveyors	219	Stand; version 51.2	282
SD – stopper damped timing belt conveyors	175	Stand; version 52.5	284
Selecting a belt conveyor	20	Stand; version 53.1	286
Selecting a chain conveyor	184	Stand; version 53.11	287
Selecting a conveyor type	8	Stand; version 53.11, mobile	288
Selecting a drive	12	Stand; version 53.2	289
Selecting a linear guide	316	Stand; version 53.21	290
Selecting a modular belt conveyor	118	Stand; version 53.21, mobile	291
Selecting a roller conveyor	246	Stand; version 53.32	292
Selecting a timing belt conveyor	154	Stand; version 54.80	282
Side rail, KFG-P 2000	79	Stand; version 55.1	285
Side rails	294	Stands	280
Side rails, KFS-P 2040.86	141	Stopper; chain conveyor	218
Side rails; adjustable	295	Stopper; timing belt conveyor	174
Side rails; fixed	294	SU – stopper undamped chain conveyors	218
Side walls	92	SU – stopper undamped timing belt conveyors	174
Single stands	282	System solutions; application examples	408
SPU 2040; application examples	414	Tails, GUF-P 2000	49
SRF-P 2010, accumulating roller chain conveyor	196	Tails, GUF-P 2004	68
SRF-P 2010; drive version AA	198	Tails, GUF-P 2041	60
SRF-P 2010; drive version AC	199	Tails, GUF-P 2045	35
SRF-P 2010; drive version AF	200	Tails, GUF-P MINI	30
SRF-P 2010; drive version AS	201	Tangential chain roller conveyor RBT-P 2255	256
SRF-P 2010; drive version BC	202	Tangential chain roller conveyor, curved section; RBT-P 2255	259
SRF-P 2010; drive version BF	203	Tangential chain roller conveyor, straight section; RBT-P 2255	258
SRF-P 2010; wear strips	204	Tensioning device and lubrication station KTF/SRF-P 2010	217
SRF-P 2012, accumulating roller chain conveyor	206	Tensioning device for SRF-P 2012	217
SRF-P 2012; drive version AA	208	Timing belt conveyor ZRF-P 2010	160
SRF-P 2012; drive version AC	209	Timing belt conveyor ZRF-P 2040	156
SRF-P 2012; drive version AS	210		

Index – Items By Item Number

16.00.0000	Initiator holder A	303	30.00.0038	Clamp, short	297
16.00.0001	Initiator holder A	303	30.00.0047	Clamp, left	297
16.00.0006	Initiator holder B	303	34.01.0001	Nut 1 M8	300
16.00.0007	Initiator holder B	303	34.01.0002	Nut 2/25 M8	300
16.00.0011	Initiator holder C	303	34.01.0006	Nut 3/50 M8	300
16.00.0012	Initiator holder C	303	34.01.0007	Nut 4/50 M8	300
16.00.0013	Initiator holder C	303	34.01.0011	Nut 2/35 M8	300
16.00.0026	Initiator holder E	303	34.01.0050	Nut 1 with spring steel sheet M8	300
16.00.0027	Initiator holder E	303	34.01.0051	Nut 1 with spring steel sheet M8	300
16.00.0028	Initiator holder E	303	34.02.0001	Nut 1 without chamfer M6	300
16.05.0011	Initiator holder A	303	34.02.0002	Nut 2/25 M6	300
21.07.0000	Wear strip mk 1040.07	137	34.02.0003	Nut 2/50 M6	300
21.12.0000	Wear strip mk 1040.12	157	34.02.0008	Nut 1 M6	300
21.13.0000	Wear strip mk 1040.13	157	34.02.0010	Nut 2/25 M6	300
21.14.0001	Lower wear strip	168/194/195	34.02.0050	Nut 1 with spring steel sheet M6	300
21.16.0000	Wear strip mk 1040.16	121	34.02.0051	Nut 1 with spring steel sheet M6	300
21.17.0000	Wear strip mk 1040.17	125/131	34.03.0002	Slot nut M8	300
22.05.2000	Wear strip mk 1005	85	34.04.0003	Slot nut M6	300
22.22.2000	Wear strip mk 1022	213	34.06.0002	T-nut M8	300
22.33.2000	Wear strip mk 1033	194	34.07.0002	T-nut M6	300
22.34.2000	Wear strip mk 1034	187/194	34.07.0003	T-nut M5	300
22.37.2000	Wear strip mk 1037	194	34.07.0004	T-nut M4	300
22.38.2000	Wear strip mk 1038	194	34.09.0003	Side walls for round rod	297
22.41.2000	Wear strip mk 1041	161/168	34.09.0004	Side walls for round rod	297
22.42.2000	Wear strip mk 1042	168	34.16.0431	Swivel-in nut 1 M4	300
22.44.0000	Wear strip mk 1044	229	34.16.0531	Swivel-in nut 1 M5	300
22.44.2000	Wear strip SBF-P 2254	233	34.16.0537	Swivel-in nut 1 M5	300
22.45.0000	Wear strip mk 1045	229	34.16.0631	Swivel-in nut 1 M6	300
22.45.2000	Wear strip SBF-P 2254	233	34.16.0637	Swivel-in nut 1 M6	300
22.47.2000	Wear strip mk 1047	197/204	34.16.0831	Swivel-in nut 1 M8	300
22.48.2000	Wear strip mk 1048	197/204	34.16.0834	Swivel-in nut 2/40 M8	300
22.50.2000	Wear strip mk 1050	207/213	34.16.0835	Swivel-in nut 3/25 M8	300
22.89.2000	Wear strip mk 1089	207/213	34.16.0837	Swivel-in nut 1 M8	300
23.11.2000	Wear strip mk 1111	195	38.07.	Clamping profile mk 2038.07	346
23.12.2000	Wear strip mk 1112	204	38.12.	Clamping profile mk 2038.12	347
25.01.	Mounting profile mk 2025.01	339	38.20.	Clamping profile mk 2038.20	346
25.02.	Mounting profile mk 2025.02	339	38.21.	Clamping profile mk 2038.21	346
25.03.	Mounting profile mk 2025.03	339	38.30.	Clamping profile mk 2038.30	346
25.04.	Mounting profile mk 2025.04	339	38.31.	Clamping profile mk 2038.31	346
25.05.	Mounting profile mk 2025.05	339	38.32.	Clamping profile mk 2038.32	346
25.75.2000	Wear strip mk 1025.75	261	38.33.	Clamping profile mk 2038.33	346
30.00.0001	Clamp	297	38.36.	Clamping profile mk 2038.36	347
30.00.0002	Clamp	297	38.41.	Clamping profile mk 2038.41	347
30.00.0013	Clamp, right	297	38.44.	Clamping profile mk 2038.44	347
30.00.0017	Clamp	297	38.46.	Clamping profile mk 2038.46	347
30.00.0023	Swivel clamp	298	38.50.	Clamping profile mk 2038.50	348
30.00.0024	Swivel clamp	298	38.55.	Clamping profile mk 2038.55	348

38.56.	Clamping profile mk 2038.56	348	60.02.	Mounting profile mk 2060.02	345
38.60.	Clamping profile mk 2038.60	348	60.03.	Mounting profile mk 2060.03	345
38.61.	Clamping profile mk 2038.61	348	60.04.	Mounting profile mk 2060.04	345
38.75.	Clamping profile mk 2038.75	347	60.05.	Mounting profile mk 2060.05	345
38.77.	Clamping profile mk 2038.77	347	60.07.	Mounting profile mk 2060.07	345
45.41.	Profile mk 2045.41	33/121/125	63.00.0016	Washer, ø 30	298
50.02.0023	Base plate 1	283	7000AA....	Rod, ø 12	299
50.02.0089	Base plate 7	283	7000AD....	Rod, ø 12	299
51.00.	Mounting profile mk 2000	343	7000AF....	Guide rod, ø 12	299
51.00.	Profile mk 2000	37/71/85	7000CA....	Guide rod, ø 12	299
51.01.	Profile mk 2001	85	7000CC....	Guide rod, ø 12	299
51.04.	Mounting profile mk 2004	343	7000DB....	Guide rod, ø 12	299
51.04.	Profile mk 2004	63	7003AA....	Guide rod	Cf 53 351
51.05.	Mounting profile mk 2005	343	7003AK....	Guide rod	Cf 53 351
51.06.	Mounting profile mk 2006	343	7003AM....	Guide rod	Cf 53 351
51.08.	Mounting profile mk 2008	343	7003CM....	Guide rod	Cf 53 351
51.09.	Mounting profile mk 2009	343	7003DC....	Guide rod, galvan.	Cf 53 351
51.10.	Profile mk 2010	161/187/197	7003DH....	Guide rod, galvan.	Cf 53 351
51.11.	Mounting profile mk 2011	343	7003DP....	Guide rod, galvan.	Cf 53 351
51.12.	Profile mk 2012	207	7003DT....	Guide rod, galvan.	Cf 53 351
51.23.	Mounting profile mk 2023	343	7003EC....	Guide rod X46 Cr13	351
51.65.	Profile mk 2065	249	7003EH....	Guide rod X46 Cr13	351
51.66.	Profile mk 2066	249	7003EP....	Guide rod X46 Cr13	351
51.75.	Profile mk 2075	23	7003ET....	Guide rod X46 Cr13	351
51.76.	Profile mk 2100	23	B01.00.409	SBF-P 2254 drive AC	231
51.77.	Profile mk 2150	23	B01.00.410	SBF-P 2254 drive AC	231
52.51.	Profile mk 2251	53	B02.99.151	Earth terminal	300
52.54.	Profile mk 2254	229	B03.00.003	Wiper ø 10	351
52.55.	Profile mk 2255	257/261	B03.00.004	Wiper ø 16	351
54.01.	Mounting profile mk 2040.01	341	B03.00.011	Felt wiper system 2015	322
54.01.	Profile mk 2040.01	71/81	B03.00.012	Felt wiper system 2011	322
54.02.	Mounting profile mk 2040.02	341	B03.00.013	Wiper ø 20	351
54.02.	Profile mk 2040.02	229	B03.00.014	Wiper ø 6	351
54.03.	Mounting profile mk 2040.03	341	B08.00.409	SBF-P 2254 section	231
54.03.	Profile mk 2040.03	157	B08.00.410	SBF-P 2254 section	231
54.05.	Mounting profile mk 2040.05	341	B16.08.000	Reglomat 180DC-3A	302
54.06.	Mounting profile mk 2040.06	341	B16.08.001	Reglomat 180DC-3ARV	302
54.07.	Mounting profile mk 2040.07	341	B16.08.100	Reglomat 230AC-250	302
54.08.	Mounting profile mk 2040.08	341	B16.08.101	Reglomat 230AC-250RV	302
54.10.	Mounting profile mk 2040.10	341	B16.08.102	Reglomat 230AC-370	302
54.21.	Profile mk 2040.21	81	B16.08.103	Reglomat 230AC-370RV	302
54.40.	Profile mk 2040.40	257	B16.08.104	Reglomat 230AC-550	302
54.73.	Mounting profile mk 2040.73	341	B16.08.105	Reglomat 230AC-550RV	302
54.80.	Profile mk 2040.80	131	B16.08.106	Reglomat 230AC-750	302
54.85.	Profile mk 2040.85	257/261	B16.08.107	Reglomat 230AC-750RV	302
54.86.	Profile mk 2040.86	137	B17.00.003	Side rail SF1.3	294
60.01.	Mounting profile mk 2060.01	345	B17.00.004	Side rail SF2.1	294

Index – Items By Item Number

B17.00.005	Side rail SF2.2	294	B20.10.568	SRF-P 2012 AS	201
B17.00.020	Side rail SF10.1, straight section	296	B20.10.571	SRF-P 2012 BC	202
B17.00.021	Side rail SF10.2, curved section	296	B20.10.572	SRF-P 2012 BF	203
B17.00.026	Side rail SF 8.1	141	B20.11.701	DGF-P 2001 AC belt	86
B17.00.035	Side rail KFG-P 2000	79	B20.12.007	SRF-P 2012 AC	209
B17.00.101	Side rail SF01	295	B20.12.008	SRF-P 2012 AA	208
B17.00.102	Side rail SF02	295	B20.12.009	SRF-P 2012 AS	210
B17.00.103	Side rail SF03	295	B20.12.010	SRF-P 2012 BC	211
B17.01.010	Side rail strip type 21	295	B20.12.011	SRF-P 2012 BF	212
B17.01.013	Side rail strip type 01	295	B20.14.001	GUF-P 2004 AC	65
B17.01.014	Side rail strip type 22	295	B20.14.002	GUF-P 2004 AS	67
B17.01.015	Side rail strip type 23	295	B20.14.003	GUF-P 2004 AM	66
B17.01.016	Side rail strip type 24	295	B20.14.009	GUF-P 2004 AA	64
B17.01.017	Side rail strip type 11	295	B20.40.001	GUF-P 2041 AC	55
B17.01.018	Side rail strip type 12	295	B20.40.003	GUF-P 2041 AS	57
B20.00.001	GUF-P 2000 BA	45	B20.40.004	GUF-P 2041 BC	58
B20.00.002	GUF-P 2000 AC	39	B20.40.005	GUF-P 2041 CA	59
B20.00.003	GUF-P 2000 AM	42	B20.40.008	GUF-P 2041 AF	56
B20.00.004	GUF-P 2000 BC	46	B20.40.009	GUF-P 2041 AA	54
B20.00.005	GUF-P 2000 AG	41	B20.40.020	KGF-P 2040 BC, 90° curve	82
B20.00.008	GUF-P 2000 AS	43	B20.40.021	KGF-P 2040 BC, 180° curve	82
B20.00.009	GUF-P 2000 AA	38	B20.40.301	ZRF-P 2040 AC	158
B20.00.010	KFG-P 2000 AC	72	B20.40.302	ZRF-P 2040 AS	159
B20.00.010	KFG-P 2000 AF	73	B20.40.605	KFS-P 2040.86 AC, type G	138
B20.00.010	KFG-P 2000 AS	74	B20.40.605	Stand KFS-P 2040.86 AC, type G	140
B20.00.010	KFG-P 2000 AU	75	B20.40.606	KFS-P 2040.86 AC, type S	138
B20.00.011	GUF-P 2000 AF	40	B20.40.606	Stand KFS-P 2040.86 AC, type S	140
B20.00.012	GUF-P 2000 BF	47	B20.40.607	KFS-P 2040.86 AC type K	138
B20.00.015	KFG-P 2000 ECO	76	B20.40.607	Stand KFS-P 2040.86 AC, type K	140
B20.00.020	GUF-P 2000 AU	44	B20.40.608	KFS-P 2040.86 AC, type L	138
B20.00.025	GUF-P 2000 CA	48	B20.40.608	Stand KFS-P 2040.86 AC, type L	140
B20.10.350	ZRF-P 2010 AA	162	B20.40.609	KFS-P 2040.86 AS, type G	139
B20.10.351	ZRF-P 2010 AC	163	B20.40.609	Stand KFS-P 2040.86 AS, type G	140
B20.10.355	ZRF-P 2010 AS	165	B20.40.610	KFS-P 2040.86 AS, type S	139
B20.10.356	ZRF-P 2010 BC	166	B20.40.610	Stand KFS-P 2040.86 AS, type S	140
B20.10.357	ZRF-P 2010 AF	164	B20.40.611	KFS-P 2040.86 AS, type K	139
B20.10.359	ZRF-P 2010 BF	167	B20.40.611	Stand KFS-P 2040.86 AS, type K	140
B20.10.359.600	Wear strip mk 1110	168	B20.40.612	KFS-P 2040.86 AS, type L	139
B20.10.465	KTF-P 2010 AA	188	B20.40.612	Stand KFS-P 2040.86 AS, type L	140
B20.10.466	KTF-P 2010 AC	189	B20.40.806	MBF-P 2040 AC	122
B20.10.467	KTF-P 2010 AF	190	B20.40.807	MBF-P 2040 AS	123
B20.10.468	KTF-P 2010 AS	191	B20.40.810	KFM-P 2040 AC type S	126
B20.10.471	KTF-P 2010 BC	192	B20.40.811	KFM-P 2040 AC type K	126
B20.10.472	KTF-P 2010 BF	193	B20.40.812	KFM-P 2040 AC type L	126
B20.10.565	SRF-P 2012 AA	198	B20.40.813	KFM-P 2040 AS type S	127
B20.10.566	SRF-P 2012 AC	199	B20.40.814	KFM-P 2040 AS type K	127
B20.10.567	SRF-P 2010 AF	200	B20.40.815	KFM-P 2040 AS type L	127

B20.40.820	KMF-P 2040 AS	type L	134	B46.02.004	Swivel clamp, complete	298
B20.40.821	KMF-P 2040 AS	type S	134	B46.02.005	Swivel clamp, complete	298
B20.40.822	KMF-P 2040 AS	type U	134	B46.07.020	Connecting kit	322
B20.40.823	KMF-P 2040 AF	type L	134	B46.07.021	Connecting kit	322
B20.40.824	KMF-P 2040 AF	type S	134	B46.10.001	Drive control for rollers, type 66	265
B20.40.825	KMF-P 2040 AF	type U	134	B46.10.002	Drive control for rollers, type 67	265
B20.40.826	KMF-P 2040 AC	type L	134	B51.04.004	Profile guide PF 1638.44	370
B20.40.827	KMF-P 2040 AC	type S	134	B51.04.015	Profile guide PF 1038.41/60	368
B20.40.828	KMF-P 2040 AC	type U	134	B51.04.016	Profile guide PF 1638.44/61	370
B20.45.001	GUF-P 2045 CA		34	B51.04.020	Profile guide PF 1038.41	368
B20.75.001	GUF-P MINI AC		25	B51.04.025	Profile guide PF 638.20	352
B20.75.004	GUF-P MINI AG		27	B51.04.029	Profile guide PF 638.20/50	352
B20.75.005	GUF-P MINI BC		29	B51.04.030	Profile guide PF 638.21	354
B20.75.009	GUF-P MINI AA		24	B51.04.042	Profile guide PF 638.30	356
B20.75.030	GUF-P MINI BA		28	B51.04.043	Profile guide PF 638.30/55	356
B20.75.033	GUF-P MINI AD		26	B51.04.046	Profile guide PF 1038.31	358
B36.00.414	SBF-P 2254, sliding curve		232	B51.04.047	Profile guide PF 1038.31/55	358
B36.00.415	SBF-P 2254, sliding curve		232	B51.04.048	Profile guide PF 1038.32	360
B36.00.416	SBF-P 2254, sliding curve		232	B51.04.049	Profile guide PF 1038.32/56	360
B36.00.417	SBF-P 2254, sliding curve		232	B51.04.052	Profile guide PF 1638.33	362
B36.00.428	SBF-P 2254, rolling curve, 90°		232	B51.04.053	Profile guide PF 1638.33/56	362
B36.00.429	SBF-P 2254, rolling curve, 90°		232	B51.04.109	Profile guide PF 1638.36	372
B36.00.430	SBF-P 2254, rolling curve, 180°		232	B51.04.140	Profile guide PF 638.75	364
B36.00.431	SBF-P 2254, rolling curve, 180°		232	B51.04.142	Profile guide PF 1038.77	366
B36.00.434	SBF-P 2254, vertical incline		233	B51.04.404	Track, KU 25.10	388
B36.00.435	SBF-P 2254, vertical incline		233	B51.04.406	Track, KU 30.10	390
B36.00.436	SBF-P 2254, vertical incline		233	B60.02.011	Guide roller, centric	350
B36.00.438	SBF-P 2254, vertical incline		233	B60.02.012	Guide roller, eccentric	350
B36.00.439	SBF-P 2254, vertical incline		233	B60.02.013	Guide roller, centric	350
B36.00.440	SBF-P 2254, vertical incline		233	B60.02.014	Guide roller, eccentric	350
B37.00.002	SBF-P 2254, transfer segment		233	B60.02.015	Guide roller, centric	350
B37.00.003	SBF-P 2254, transfer segment		233	B60.02.016	Guide roller, eccentric	350
B38.02.003	LZR 2000-38.41-15	L1 150	376	B60.02.017	Guide roller, centric	350
B38.02.003	LZR 2000-38.41-15	L1 250	376	B60.02.018	Guide roller, eccentric	350
B38.02.004	LZR 2004-38.41-30	L1 150	378	B61.00.001	RBS-P 2065/2066 ø 20	250
B38.02.004	LZR 2004-38.41-30	L1 250	378	B61.00.002	RBS-P 2065/2066 ø 40	250
B38.02.005	LZR 2004-38.41-30	L1 250	379	B61.00.003	RBS-P 2065/2066 ø 50	250
B38.02.005	LZR 2004-38.41-30	L1 450	379	B61.00.004	RBS-P 2066	251
B38.02.006	LZR 2005-38.44-30	L1 250	380	B61.02.001	RBS-P 2255	254
B38.02.006	LZR 2005-38.44-30	L1 450	380	B61.02.002	RBS-P 2255	255
B38.02.007	LZR 2000-38.41-15	L1 250	377	B61.02.003	RBT-P 2255	258
B38.02.009	LZR 2005-38.44-30	L1 250	381	B61.02.004	RBT-P 2255	259
B38.02.009	LZR 2005-38.44-30	L1 450	381	B61.02.005	RBM-P 2255	262
B38.02.010	LZR 2011-38.44-30	L1 250	383	B61.02.006	RBM-P 2255	263
B38.02.010	LZR 2011-38.44-30	L1 450	383	B66.00.003	End stop RBS-P 2065/66	304
B38.02.011	LZR 2011-38.44-30	L1 250	382	B66.00.004	End stop GUF-P 2000	304
B38.02.011	LZR 2011-38.44-30	L1 450	382	B67.03.002	Stand 31	293

Index – Items By Item Number

B67.04.002	Stand 51.2	282	B85.00.122	Adjusting unit VST 2011-D-2 ø 100	330
B67.04.080	Stand 54.80	282	B85.00.125	Adjusting unit VST 2011-H-2 ø 125	330
B67.05.008	Stand 52.5	284	B85.00.126	Adjusting unit VST 2011-S-2 ø 125	330
B67.06.001	Stand 53.1	286	B85.00.127	Adjusting unit VST 2011-D-2 ø 125	330
B67.06.002	Stand 53.11	287	B85.00.215	Adjusting unit VST 2015-H-G	327
B67.06.003	Stand 53.2	289	B85.00.216	Adjusting unit VST 2015-S-G	327
B67.06.004	Stand 53.21	290	B85.00.217	Adjusting unit VST 2015-D-G	327
B67.06.011	Stand 55.1	285	B85.00.220	Adjusting unit VST 2011-H-G ø 100	331
B67.06.014	Stand, incline conveyor	78/128	B85.00.221	Adjusting unit VST 2011-S-G ø 100	331
B67.06.015	Stand, incline conveyor	78/128	B85.00.222	Adjusting unit VST 2011-D-G ø 100	331
B67.06.016	Stand 53.32	292	B85.00.225	Adjusting unit VST 2011-H-G ø 125	331
B67.06.100	Stand 53.11, mobile	288	B85.00.226	Adjusting unit VST 2011-S-G ø 125	331
B67.06.101	Stand 53.21, mobile	291	B85.00.227	Adjusting unit VST 2011-D-G ø 125	331
B80.00.001	Tail 07, GUF-P 2000	49	B90.25.041	Roller carriage LW 38.2004 L1 75	353
B80.00.002	Tail 17, GUF-P 2000	51	B90.25.041	Roller carriage LW 38.2004 L1 100	353
B80.00.005	Tail 09, GUF-P 2000	49	B90.25.042	Roller carriage LW 38.2104 L1 100	355
B80.00.006	Tail 19, GUF-P 2000	50	B90.25.042	Roller carriage LW 38.2104 L1 150	355
B80.00.007	Tail 11, GUF-P 2000	49	B90.40.041	Roller carriage LW 38.3004 L1 100	357
B80.00.017	Tail 10, GUF-P 2000	51	B90.40.041	Roller carriage LW 38.3004 L1 160	357
B80.00.018	Tail 13, GUF-P 2000	50	B90.40.042	Roller carriage LW 38.3104 L1 140	359
B80.00.409	SBF-P 2254 tail	231	B90.40.042	Roller carriage LW 38.3104 L1 240	359
B80.00.410	SBF-P 2254 tail	231	B90.40.043	Roller carriage LW 38.3204 L1 180	361
B80.01.001	Tail 03, GUF-P MINI	30	B90.40.043	Roller carriage LW 38.3204 L1 280	361
B80.01.004	Tail 19, GUF-P MINI	31	B90.40.044	Roller carriage LW 38.3304 L1 240	363
B80.01.006	Tail 01, GUF-P MINI	30	B90.40.044	Roller carriage LW 38.3304 L1 400	363
B80.01.007	Tail 11, GUF-P MINI	31	B90.40.441	Roller carriage LW 38.7544 L1 120	365
B80.02.004	Tail 01, GUF-P 2004	68	B90.40.443	Roller carriage LW 38.7744 L1 160	367
B80.02.005	Tail 09, GUF-P 2004	68	B90.50.042	Roller carriage LW 38.4104 L1 150	369
B80.07.001	Tail 01, GUF-P 2041	60	B90.50.042	Roller carriage LW 38.4104 L1 250	369
B80.07.002	Tail 19, GUF-P 2041	61	B90.50.044	Roller carriage LW 38.4404 L1 250	371
B80.07.009	Tail 02, GUF-P 2041	60	B90.50.044	Roller carriage LW 38.4404 L1 450	371
B80.07.010	Tail 13, GUF-P 2041	61	B90.60.042	Roller carriage LW 38.3604 L1 280	373
B80.45.001	Tail 01, GUF-P 2045	35	B90.60.042	Roller carriage LW 38.3604 L1 480	373
B85.00.015	Adjusting unit VST 2015-H	325	K101100001	Track roller assembly LR 10	337
B85.00.016	Adjusting unit VST 2015-S	325	K101100002	Track roller assembly LR 16	337
B85.00.017	Adjusting unit VST 2015-D	325	K101100003	Track roller assembly LR 6	337
B85.00.020	Adjusting unit VST 2011-H ø 100	329	K101100006	Track roller assembly LR 20	337
B85.00.021	Adjusting unit VST 2011-S ø 100	329	K10230/12	Closure strip	168/194/195
B85.00.022	Adjusting unit VST 2011-D ø 100	329	K1029001	Belt GU-U0302-001WE	90
B85.00.025	Adjusting unit VST 2011-H ø 125	329	K1029003	Belt GU-T0105-003BL	89
B85.00.026	Adjusting unit VST 2011-S ø 125	329	K1029004	Belt GU-U0305-004WE	90
B85.00.027	Adjusting unit VST 2011-D ø 125	329	K1029005	Belt GU-R0303-005DG	91
B85.00.115	Adjusting unit VST 2015-H-2	326	K1029006	Belt GU-V0203-006DG	90
B85.00.116	Adjusting unit VST 2015-S-2	326	K1029007	Belt GU-U0204-007WE	89
B85.00.117	Adjusting unit VST 2015-D-2	326	K1029008	Belt GU-T0101-008BL	89
B85.00.120	Adjusting unit VST 2011-H-2 ø 100	330	K1029009	Belt GU-V0303-009DG	91
B85.00.121	Adjusting unit VST 2011-S-2 ø 100	330	K1029010	Belt GU-V0103-010SW	89

K1029011	Belt GU-U0205-011DG	90	K11423	Accumulating roller chain	215
K1029012	Belt GU-U0306-012DG	91	K11424	Accumulating roller chain	215
K1029013	Belt GU-V0307-013DG	91	K11425	Accumulating roller chain	215
K1029014	Belt GU-V0306-014DG	91	K11435	Accumulating roller chain	215
K1029015	Belt GU-U0107-015DG	89	K114510022	Chain, steel	234
K1029016	Belt GU-U0305-016DG	91	K114510030	Chain, plastic	234
K1029017	Belt GU-U0306-017WE	90	K114510031	Chain, plastic	234
K1029018	Belt GU-V0307-018SW	91	K114510044	Chain, plastic	234
K1029019	Belt GU-F0106-019SW	89	K114510047	Chain, steel	234
K1029024	Belt GU-U0305-024LB	90	K114510048	Chain, plastic	234
K1029028	Belt GU-V0106-028DG	89	K114510062	Chain, steel	234
K1029029	Belt GU-U0210-029DG	90	K114510063	Chain, steel	234
K1029030	Belt GU-U0308-030LB	90	K114510085	Chain, plastic	234
K1029050	Belt GU-U0205-050LB	89	K114510090	Chain, plastic	234
K106043	Roller type 43	264	K114510091	Chain, plastic	234
K106044	Roller type 44	264	K114510094	Chain, plastic	234
K106045	Roll type 45	264	K11455	Modular belt S10	142
K106046	Roller type 46	264	K11455	Modular belt S8	142
K106047	Roller type 47	264	K11455	Modular belt ASB 2.2	144
K106048	Roller type 48	264	K116041025	Track, KU 25.10	388
K106049	Roller type 49	264	K116041030	Track, KU 30.10	390
K106050	Roller type 50	264	K116041125	Guide carriage KU 25.11	389
K106051	Roller type 51	265	K116041130	Guide carriage KU 30.11	391
K106052	Roller type 52	265	K116041325	Guide carriage KU 25.13	389
K106055	Roller type 55	265	K116041330	Guide carriage KU 30.13	391
K106056	Roller type 56	265	K307000002	Sensor cable	303
K106057	Roller type 57	264	K307000017	Sensor cable	303
K106058	Roller type 58	264	K307000018	Sensor cable	303
K106059	Roller type 59	264	K308000009	Inductive sensor	303
K106060	Roller type 60	264	K308000010	Inductive sensor	303
K106061	Roller type 61	264	K309000052	Clamp mount	303
K106066	Roller type 66	265	K309000053	Clamp mount	303
K106066VK54	Extension cable	265	K309000124	Inductive sensor	303
K106067	Roller type 67	265	K503011401	Stopper SU 400	174/218
K110030061	Clamping lever	322	K503011402	Stopper SU 400	174/218
K11402	Single roller chain	214	K503011404	Stopper SU 400	174/218
K114020001	Locking link	214	K503011405	Stopper SU 400	174/218
K11406	Accumulating roller chain	214	K503011406	Stopper SU 400	174/218
K114060001	Locking link	214	K503012401	Stopper SU 400	174/218
K11407	Accumulating roller chain	215	K503012404	Stopper SU 400	174/218
K11415	Accumulating roller chain	215	K503012405	Stopper SU 400	174/218
K11418	Accumulating roller chain	215	K503021061	Stopper SD 60	175/219
K114180001	Locking link	215	K503021063	Stopper SD 60	175/219
K11420	Accumulating roller chain	215	K503021064	Stopper SD 60	175/219
K11420	Accumulating roller chain	215	K503021101	Stopper SD 100	175/219
K11421	Accumulating roller chain	215	K503021102	Stopper SD 100	175/219
K11422	Accumulating roller chain	215	K503022061	Stopper SD 60	175/219

Copyright © 2019 Maschinenbau Kitz GmbH
Edition 4.0
Printed 01/2019

All rights reserved. Technical information subject to change without notice. Reproduction, whether in full or in part, requires the written consent of Maschinenbau Kitz GmbH. This also applies for use in digital media and systems. The place of jurisdiction shall be Siegburg, Germany.



Maschinenbau Kitz GmbH
Headquarters of the
mk Technology Group

Ampèrestrasse 18
53844 Troisdorf
Germany

Tel. +49 228 4598-0
info@mk-group.com

www.mk-group.com



Edition 4.0