



Technical
Documentation

SRF-P 2045 ACCUMULATING ROLLER CHAIN CONVEYOR

Each serial number is unique to that specific unit and provides mk North America with complete order details.

The serial number is located on the frame of the conveyor. See section 2 for more details.

1	General Information	3
2	Decoding Your Serial Number	4
3	Conveyor Description	5
4	Warranty Information	7
5	Safety Requirements	8
6	Wear Items & Maintenance	10
7	Conveyor Chain Maintenance - Tensioning	14
8	Conveyor Chain Maintenance - Chain Replacement	15
9	Lubrication Station - Optional Accessory	16
10	Contact Information	17

1 GENERAL INFORMATION

1.1 Foreword

Congratulations on purchasing a conveyor from mk North America, Inc., a leading manufacturer of quality low profile conveyors. Our more than 30 years experience in material handling allows us to offer robust solutions with long life and reliable operation. We strive to make the best products in the industry even better and we are committed to making sure our customers get top notch support before, during, and after each and every sale.

1.2 The importance of reading your manual

Inside this manual you will find the instructions on how to set up and maintain your mk conveyor properly, as well as maximize its performance. Please take the time to read this manual and familiarize yourself with these set up and maintenance instructions. These instructions will help assure a long product life that requires a minimum amount of service and keeps your conveyor working at its maximum capacity.

1.3 If you need assistance

If you need assistance there are a variety of ways to get it. You can contact our customer service team Monday through Friday, 8am-5pm (Eastern Time) at (860) 769-5500. You can also visit our website for additional information and technical documentation at www.mknorthamerica.com. In addition, your local representative can provide support in many instances.

1.4 When your shipment arrives

- 1) Check your shipment
 - a) If you have not already done so, visually inspect the shipping crate/container for any damage caused during shipment.
 - b) Carefully unpack the crate/container making sure to inspect the components for damage that may have occurred inside the packaging materials.
 - c) If you find any damage, please contact the carrier and mk North America, Inc.
 - d) Lastly, check the contents against the packing slip provided by mk for any discrepancies. If you should find any, please contact mk North America, Inc.
- 2) Locate your ordered items
 - a) Each mk conveyor will ship in its own custom built container, carefully packaged in the most economical way.
 - b) Review the packing slip against your Purchase Order.

2 SERIAL NUMBER LABEL

- The conveyor's serial number is located on the frame at the drive end of the conveyor.

	Type:		Date:	
	Serial #:		CO #:	
	Drawing #:			
	www.mknorthamerica.com (860) 769-5500			
				Scan for Documentation

Type:

This description refers to the type of unit that is associated with the particular serial number. The type should NOT be substituted for the serial number when inquiring.

Serial #:

This number is unique to this item. With this number we can access all of the original order details.

Drawing #:

This number, if applicable, refers to the specific drawing that was created for this unit.

Date:

This is the date that the unit was scheduled to ship.

CO#:

This is the customer order number in which this unit was built. This is an mk North America, Inc. internal number. This number is also referenced on any related invoices, etc.

Scan for Documentation:

Scanning this QR code will bring you to a webpage specific for the conveyor on this order. From here you can access drawings and spare parts.

3 CONVEYOR DESCRIPTION

3.1 Explaining the conveyor **TYPE**.

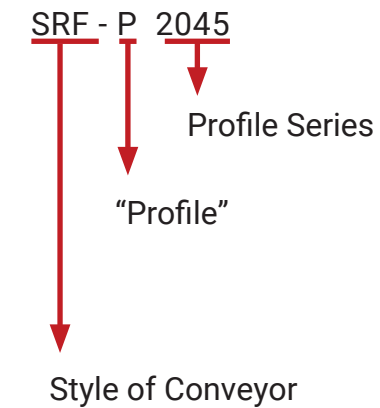

Style of Conveyor

DGF (Doppel-Gurt Foerderer) Dual-Belt Conveyor

GUF (Gurt Foerderer) Belt Conveyor

KFG (Knickfoerderer Gurt) Bent "Gooseneck" Belt Conveyor

KFM (Knickförder Modular) Bent "Gooseneck" Plastic Modular Belt Conveyor

KGF (Kurvengurt Foerderer) Curve Belt Conveyor

KMF (Kurvengängiges Modulband) Curved Modular Belt Conveyor

KTF (Kettengurt Foerderer) Chain Conveyor

MBF (Modulband Foerderer) Modular Belt Conveyor

RBM (Rollenbahn Motor) Motorized Roller Conveyor

RBS (Rollerbahn Schwerkraft) Idler Roller Conveyor

RBT (Rollenbahn Tangentialkette) Drive Roller Conveyor

SBF (Scharnierband Foerderer) Hinged Belt Conveyor

SPU (Staufaehiges Pallettenumlaufsystem) Continuous Motion Pallet Conveyor

SRF (Staurollen Foerderer) Accumulating Roller Conveyor

TKU (Taktkettenförderer) Timing Chain Conveyor

ZRF (Zahnriemen Förderer) Timing Belt Conveyor

3 CONVEYOR DESCRIPTION (CONT.)

3.2 Conveyor Components

The SRF-P 2045 has many typical conveyor components. Below is a description of the basic parts and options for the SRF-P 2045 conveyor. The items you receive will vary based on your actual purchase order. Items may appear different on your model based on your particular order requirements. Consult your approval drawing for specifics items included in your order.

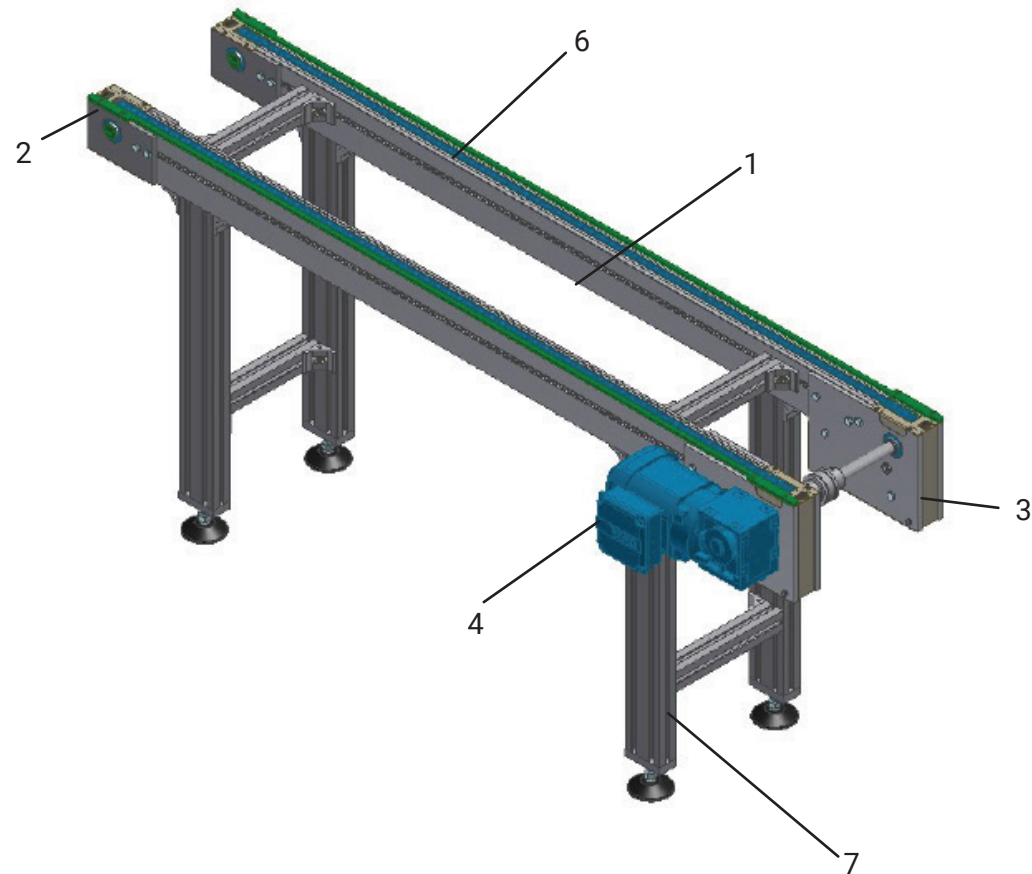

Typical Components

- 1) Conveyor Frame
- 2) Idler End
- 3) Drive End
- 4) Gearmotor
- 5) Speed Control (Not Shown)
- 6) Conveyor Chain
- 7) Support Stand

4 WARRANTY INFORMATION

Warranty

mk North America, Inc. (MKNA) offers a COMPLETE ONE YEAR WARRANTY from the date of delivery, to the original purchaser of the MKNA equipment (CUSTOMER), to be free from defects in material and workmanship; under normal use and with proper installation, maintenance and cleaning.

Additionally MKNA offers a LIMITED 10 YEAR WARRANTY on all equipment that MKNA is the original manufacturer of, to be free from defect and workmanship.¹

This warranty is extended by MKNA only to CUSTOMER, and is non-transferable. All warranty requests shall be made by CUSTOMER.

MKNA will replace or repair, at our factory or any other location we designate², any defective part within the warranty period and without charge. It is at MKNA's sole discretion whether to repair or replace. CUSTOMER will provide MKNA with a prompt written notice of the defect, including the serial number of the unit (when applicable) and the date of delivery.

At MKNA's request CUSTOMER will return all defective parts for evaluation at MKNA. MKNA will provide CUSTOMER with a return goods authorization number (RGA#). No parts will be returned without a RGA#. The RGA# must clearly be marked on all labels, packages and packing slips.

CUSTOMER shall pay all costs for packaging, shipping, duties and/or any other related costs in the sending or receiving of parts. CUSTOMER is responsible for all labor associated with sending or receiving of parts.

MKNA PROVIDES NO WARRANTY OF MERCHANTABILITY OR FITNESS FOR A PARTICULAR PURPOSE; UNLESS IT IS AGREED TO BY MKNA AND CUSTOMER IN WRITING PRIOR TO PLACEMENT OF ORDER. Such agreement requires approval of MKNA Management.

UNDER NO CIRCUMSTANCES SHALL MKNA BE HELD LIABLE FOR DAMAGES OR LIABILITY FOR LOSS OF PRODUCTION, PRODUCT, EQUIPMENT OR PROFITS OR LIABILITY FOR DIRECT, INCIDENTAL, INDIRECT, SPECIAL OR CONSEQUENTIAL DAMAGES OR ANY DAMAGES TO PERSONS OR PROPERTY, WHATSOEVER. CUSTOMER agrees that it is their sole remedy for liability of any kind, including negligence with respect to the equipment and services furnished by MKNA shall be limited to the remedies provided herein. This warranty shall not apply to any failure of the unit or its components caused by lack of maintenance and/or improper maintenance, incorrect adjustments, misuse or unreasonable use or exposure to chemicals and/or environments which the unit is not designed for. Unauthorized modification of the unit or the use of non-MKNA replacement parts and building components voids this warranty.

¹ The limited 10 year warranty does not apply to equipment and components manufactured by others. Such equipment and components are subject to any limitation contained in the original manufacturer's warranty and include, but are not limited to: bearings, belts, casters, controllers, motors and pneumatic devices.

² No work will be performed by MKNA or an MKNA factory authorized service representative at the site of installation unless in MKNA's opinion it is impractical for Customer to remove and return the defective part to MKNA's factory.

EXCEPT AS EXPRESSLY STATED HEREIN, THERE ARE NO WARRANTIES, EXPRESSED OR IMPLIED, BY OPERATION OF LAW OR OTHERWISE, OF THE EQUIPMENT OR SERVICES FURNISHED BY MKNA OR FACTORY AUTHORIZED SERVICE REPRESENTATIVE. THERE ARE NO WARRANTIES WHICH EXTEND BEYOND THE DESCRIPTION ON THE FACE HEREOF.

mk North America, Inc. reserves the right to change, modify or discontinue products and/or specifications with or without notice.

All of mk North America, Inc. products are covered by this warranty.

5 SAFETY REQUIREMENTS

5.1 Warnings - Safety Guidelines

READ AND UNDERSTAND ALL OF THESE WARNINGS PRIOR TO OPERATING EQUIPMENT.

CAUTION



Read this manual before operating conveyors.

CAUTION



Never operate or service equipment under the influence of drugs and/or alcohol.

CAUTION



Lock out power before servicing the conveyor.

WARNING



Do NOT operate conveyors without guards in place.
Severe injury can occur.

IMPORTANT



Conveyors must be installed so that they are square and level – across the belt. Failure to install conveyors correctly may cause premature equipment failure and/or product damage.

WARNING



Do not operate conveyors in an explosive environment.

DANGER



Moving equipment can cause severe injury or death.
Do NOT touch moving parts. Lock out power before servicing.

WARNING



Gearmotors will be hot. Do NOT touch.
Severe injury can occur.

DANGER



Climbing, sitting, walking or riding on the conveyor at any time could result in severe injury or death.
KEEP OFF!

DANGER



Always support conveyor sections prior to loosening stands or supports. Loosening stands or supports can cause the conveyor to fall creating a crush hazard.

5 SAFETY REQUIREMENTS

(CONT.)

NOTICE



All work should be done by qualified professionals. This includes electricians for all wiring.

6 WEAR ITEMS & MAINTENANCE

6.1	Important Notes About Wear Items & Maintenance	11
6.2	SRF-P 2045 AF	12

6 WEAR ITEMS & MAINTENANCE (CONT.)

6.1 Important Notes About Wear Items & Maintenance

The following information regarding life of the wear items and service or adjustment intervals of the functional elements are only GUIDELINES. Conveyors are application-specific products whose life expectancy can vary depending on their relative loads and speeds, and which can be significantly influenced by environmental factors.

- All moving components and screw connections should be checked every 6 months.
- All safety-relevant components should be part of a regularly scheduled weekly inspection
- The proper function of these components must be confirmed at all times.
- Do NOT operate conveyors if safety-relevant components are damaged or missing.
- All parts which contact the product should be cleaned weekly (example: chain).

6 WEAR ITEMS & MAINTENANCE (CONT.)

6.2 SRF-P 2045 AF

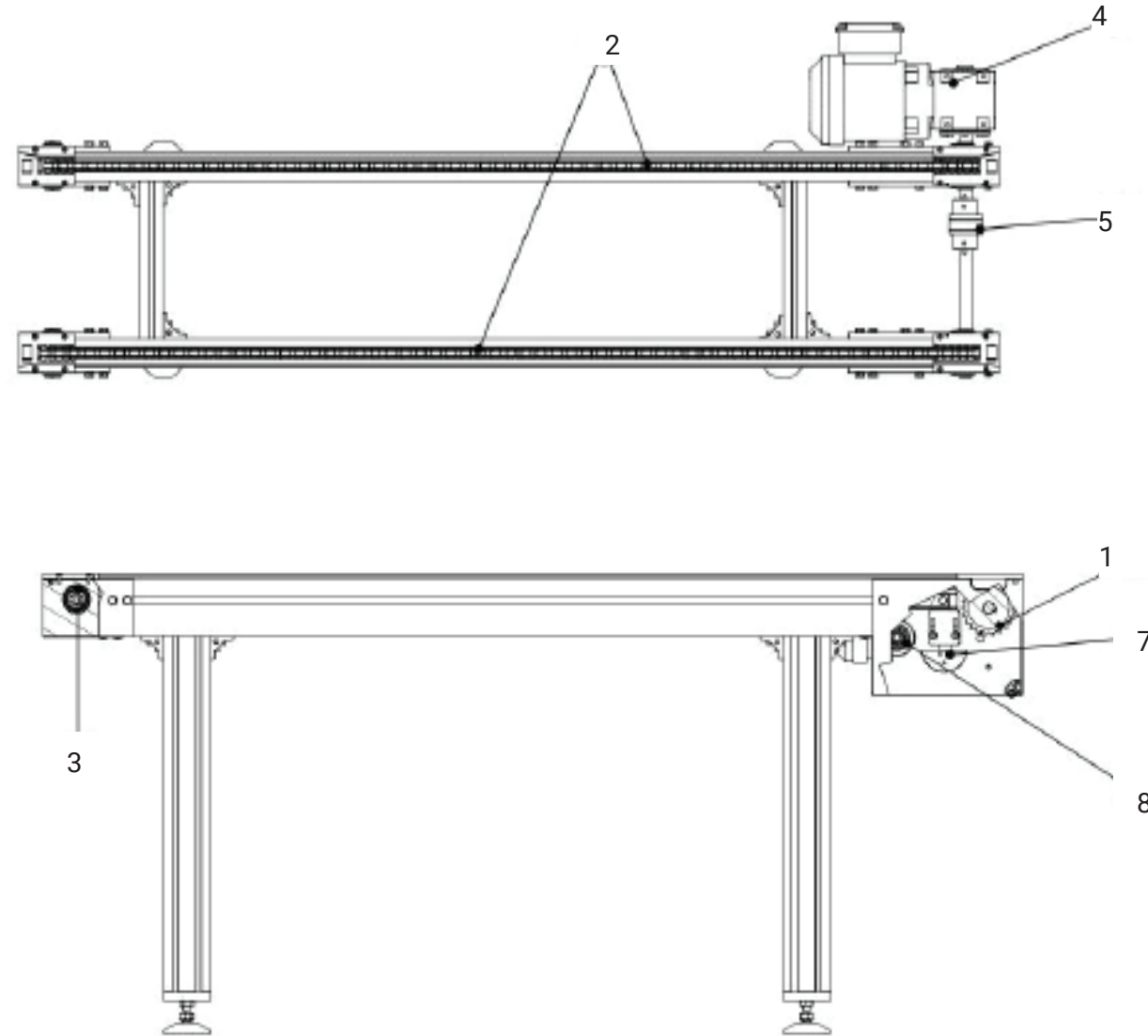

NOTE: Not all items shown in all views for clarity.

(Cont.)

6 WEAR ITEMS & MAINTENANCE (CONT.)

6.2 SRF-P 2045 (Cont.)

Maintenance Work for SRF-P 2045 AF

Position	Description	Action*	Interval in Hours (Months)	Lubricant
1	Pulley	I, C	500 Hours (Max. 3 Months)	
		R	If wear is indicated	
2	Chain	I, C, L, T	500 Hours (Max. 3 Months)	SAE20-SAE50
		R	If stretch is greater than 3%	
3	Bearing	I	1,000 Hours (Max. 6 Months)	
4	Gearmotor	I	Service & Maintenance per manufacturer's documentation	
5	Coupling	I	500 Hours (Max. 3 Months)	
6	Wear strip (not shown)	I, C	500 Hours (Max. 3 months)	
		R	If wear is indicated	
7	Tensioner	I, C	500 Hours (Max. 3 Months)	
		R	If wear is indicated	
8	Roller	I, C	1,000 House (Max. 6 Months)	
		R	If wear is indicated	

* LEGEND: *Inspect, Replace, Tension, Clean, Lubricate (grease).*

Wear Items for SRF-P 2045 AF

Position	Description	Part Number
1	Pulley	58.12.0046
2	Chain & Connecting Link	Inquire with mk North America
3	Bearing	7-20.002-462-006
4	Gearmotor	Inquire with mk North America
5	Coupling	Inquire with mk North America
6	Wear strip	Inquire with mk North America
7	Tensioner	7-20.002-402-007
8	Roller	7-20.002-402-004

7 CONVEYOR CHAIN MAINTENANCE - TENSIONING



All work to be performed by qualified personnel only.
Conveyor power must be disconnected before servicing.

Tensioning Device - General Notes

The chain is adjusted and tensioned by an automatic tensioner.
To check the chain tension, it is necessary to view the color scale on the tensioner, see below for location.

Color Scale

- Green: Chain is Ok.
- Yellow: Chain is elongated, but still OK.
- Red: Chain is elongated more than recommended. It is necessary to replace the chain.

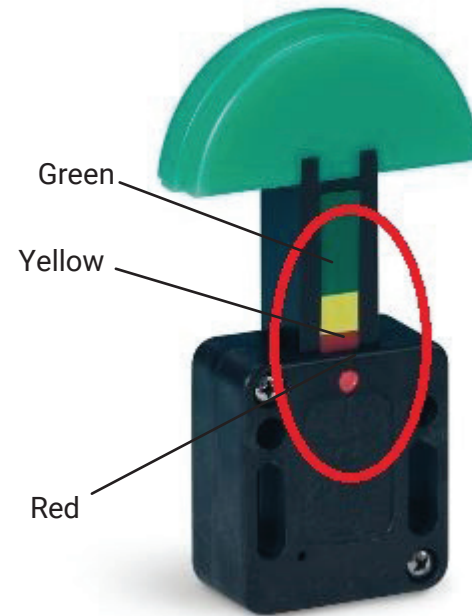

Tensioning Device - Locating

On the drive end of the conveyor, on the side opposite of the motor there is a viewing hole for the chain tensioner. It is located (1) in the image to the right.

There is a chain indicator sticker around it for identification (see image below).

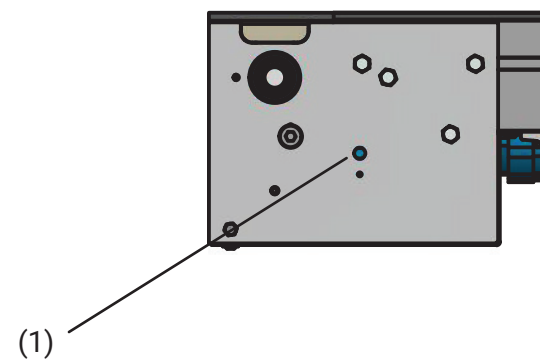

8 CONVEYOR MAINTENANCE - CHAIN REPLACEMENT



All work to be performed by qualified personnel only.
Conveyor power **must** be disconnected before replacing the chain.

Chain Replacement - Replace on Both Sides of Conveyor

Loosen screws (1) and remove the upper guard (3) and wear strip (2).

Loosen screws (4) and remove the bottom guard (5).

Turn on the shaft until the connecting link is in position (6). NOTE: It may be necessary to remove the coupling in order to turn the shaft.

Press the tensioner back, with the appropriate tool to remove tension from the roller chain. Then put a #3 Allen wrench into hole (7) to hold the tensioner in place.

The tension has been released from the chain; the chain can now be removed.

Open chain at the connecting link with the appropriate tool.

Thread chain through conveyor, joining as necessary using connecting links (master link).

Remove the allen wrench from hole (7) to engaged the tensioner.

Reassemble the conveyor in reverse order, ensuring all of the guards are in place prior to powering back on.

NOTE: When replacing the belt on the motor side, you will need to remove the motor first.

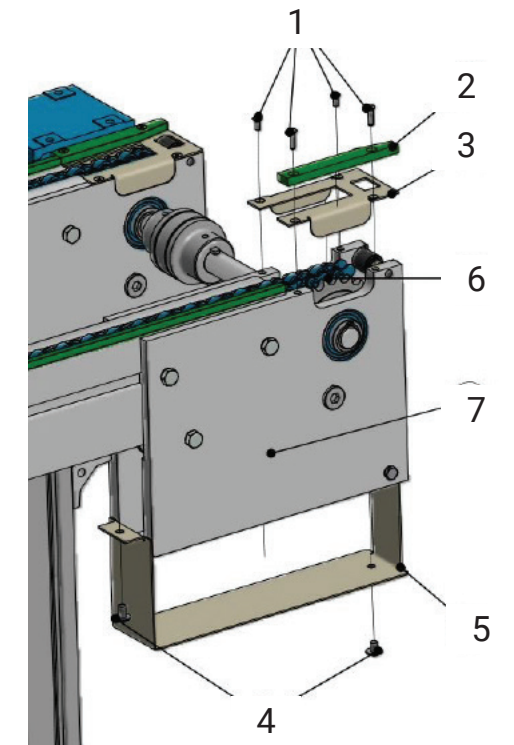

9 AUTOMATIC LUBRICATION - OPTIONAL ACCESSORY

Lubrication Station (Optional)

To check:

Check for oil leaks at both valves (2).

To Replace Oil Cartridge:

See "Instructions Manual" of the manufacturer.
The model is Star Control, from PERMA.
The oil cartridge is LC-M120-S014, of reference 101096.

NOTE: Item 1 is the programming unit and may not be on all models.

Note: Item 3 is the oil cartridge.

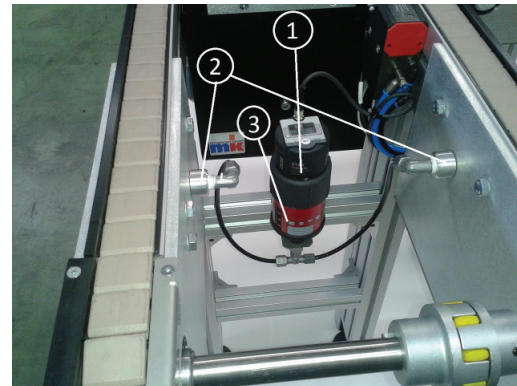

10 CONTACT INFORMATION



sales@mknorthamerica.com
spareparts@mknorthamerica.com
service@mknorthamerica.com



(860) 769-5500

Technical Documentation
SRF-P 2045
Accumulating Roller Chain
Conveyor

mk North America, Inc.
an mk Technology Group Company
105 Highland Park Drive
Bloomfield, CT 06002, USA
Phone: (860) 769-5500

www.mknorthamerica.com
sales@mknorthamerica.com

All rights reserved, information subject to change without notice. © 2024 mk North America, Inc.

REV. 2024.10.21