



Technical
Documentation

KFS-P 2040.86 STEEL-HINGED-BELT CONVEYOR

Each serial number is unique to that specific conveyor and provides mk North America with complete order details.

The conveyor serial number is located on the frame at the drive end of the conveyor. See section 2 for more details.

Technical Documentation

KFS-P 240.86

1	General Information	3
2	Serial Number Label	4
3	Conveyor Description	5
4	Warranty Information	7
5	Safety Requirements	8
6	Wear Items & Maintenance - Drive & Idler	10
7	Conveyor Belt Maintenance - Drive Train	17
8	Conveyor Belt Maintenance - Steel Belt Replacement	22
9	Contact Information	28

1 GENERAL INFORMATION

1.1 Foreword

Congratulations on purchasing a conveyor from mk North America, Inc., a leading manufacturer of quality low profile conveyors. Our more than 30 years experience in material handling allows us to offer robust solutions with long life and reliable operation. We strive to make the best products in the industry even better and we are committed to making sure our customers get top notch support before, during, and after each and every sale.

1.2 The importance of reading your manual

Inside this manual you will find the instructions on how to set up and maintain your mk conveyor properly, as well as maximize its performance. Please take the time to read this manual and familiarize yourself with these set up and maintenance instructions. These instructions will help assure a long product life that requires a minimum amount of service and keeps your conveyor working at its maximum capacity.

1.3 If you need assistance

If you need assistance there are a variety of ways to get it. You can contact our customer service team Monday through Friday, 8am-5pm (Eastern Time) at (860) 769-5500. You can also visit our website for additional information and technical documentation at www.mknorthamerica.com. In addition, your local representative can provide support in many instances.

1.4 When your shipment arrives

- 1) Check your shipment
 - a) If you have not already done so, visually inspect the shipping crate/container for any damage caused during shipment.
 - b) Carefully unpack the crate/container making sure to inspect the components for damage that may have occurred inside the packaging materials.
 - c) If you find any damage, please contact the carrier and mk North America, Inc.
 - d) Lastly, check the contents against the packing slip provided by mk for any discrepancies. If you should find any, please contact mk North America, Inc.

- 2) Locate your ordered items
 - a) Each mk conveyor will ship in its own custom built container, carefully packaged in the most economical way.
 - b) Review the packing slip against your Purchase Order.

Technical Documentation

KFS-P 240.86

2 SERIAL NUMBER LABEL

The conveyor's serial number is located on the frame at the drive end of the conveyor.

	Type: <input type="text"/>	Date: <input type="text"/>
	Serial #: <input type="text"/>	CO #: <input type="text"/>
	Drawing #: <input type="text"/>	
	www.mknorthamerica.com (860) 769-5500	
		Scan for Documentation

Type:

This description refers to the type of unit that is associated with the particular serial number. The type should NOT be substituted for the serial number when inquiring.

Serial #:

This number is unique to this item. With this number we can access all of the original order details.

Drawing #:

This number, if applicable, refers to the specific drawing that was created for this unit.

Date:

This is the date that the unit was scheduled to ship.

CO#:

This is the customer order number in which this unit was built. This is an mk North America, Inc. internal number. This number is also referenced on any related invoices, etc.

Scan for Documentation:

Scanning this QR code will bring you to a webpage specific for the conveyor on this order. From here you can access drawings and spare parts.

3 CONVEYOR DESCRIPTION

3.1 Explaining the conveyor **TYPE**.

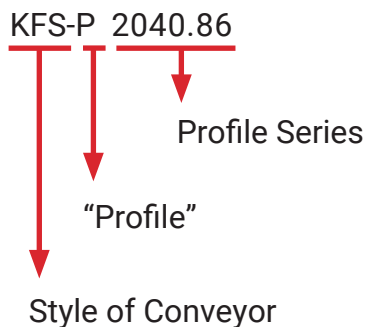

Style of Conveyor

- DGF (Doppel-Gurt Foerderer) Dual-Belt Conveyor
- GUF (Gurt Foerderer) Belt Conveyor
- KFG (Knickfoerderer Gurt) Bent "Gooseneck" Belt Conveyor
- KFS (Knickförder Modular) Bent "Gooseneck" Belt Conveyor, Steel Belt
- KGf (Kurvengurt Foerderer) Curve Belt Conveyor
- KMF (Kurvengängiges Modulband) Curved Modular Belt Conveyor
- KTF (Kettengurt Foerderer) Chain Conveyor
- MBF (Modulband Foerderer) Modular Belt Conveyor
- RBM (Rollenbahn Motor) Motorized Roller Conveyor
- RBS (Rollenbahn Schwerkraft) Idler Roller Conveyor
- RBT (Rollenbahn Tangentialkette) Drive Roller Conveyor
- SBF (Scharnierband Foerderer) Hinged Belt Conveyor
- SPU (Staufähiges Pallettenumlaufsystem) Continuous Motion Pallet Conveyor
- SRF (Staurollen Foerderer) Accumulating Roller Conveyor
- TKU (Taktkettenförderer) Timing Chain Conveyor
- ZRF (Zahnriemen Förderer) Timing Belt Conveyor

Technical Documentation

KFS-P 240.86

3 CONVEYOR DESCRIPTION

(CONT.)

3.2 Conveyor Components

The KFS-P 240.86 has many typical conveyor components. Below is a description of the basic parts and options for the KFS-P 240.86 conveyor. The items you receive will vary based on your actual purchase order. Items may appear different on your model based on your particular order requirements. Consult your approval drawing for specific items included in your order.

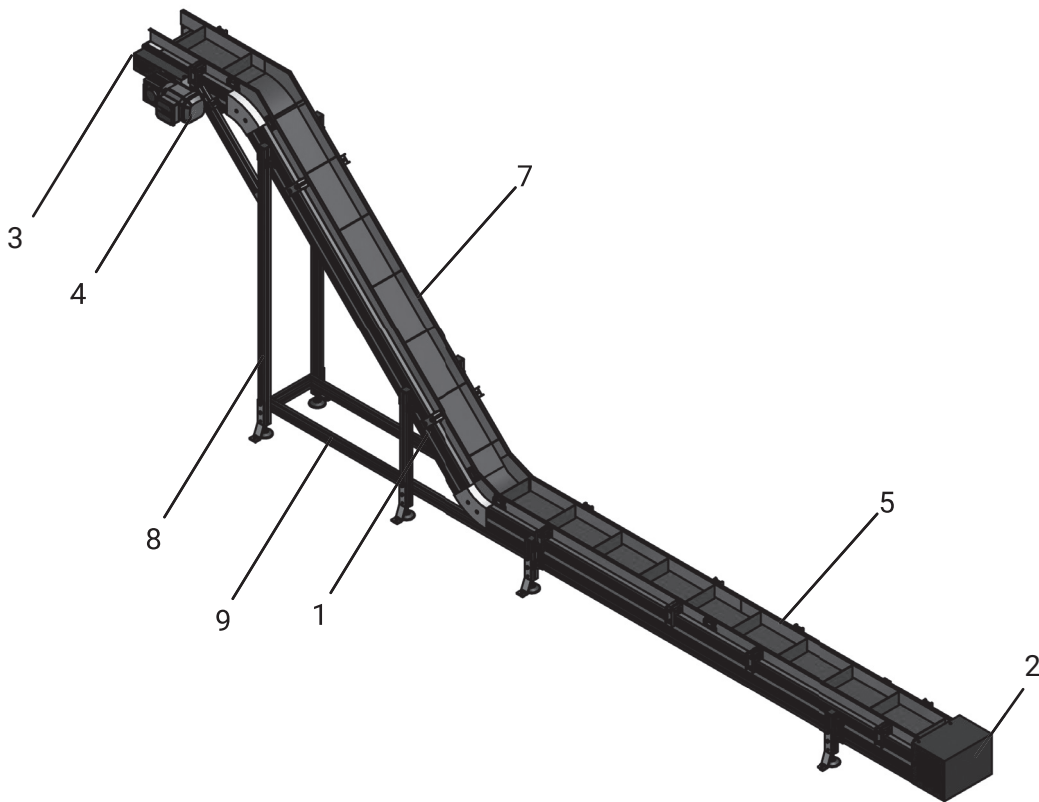

Typical Components

- 1) Conveyor Frame
- 2) Idler End
- 3) Gearmotor Mount/Drive Assembly
- 4) Gearmotor
- 5) Steel Belt
- 6) Controller (Not shown)
- 7) Side Rails
- 8) Support Stand
- 9) Stand Stringer

4 WARRANTY INFORMATION

Warranty

mk North America, Inc. (MKNA) offers a COMPLETE ONE YEAR WARRANTY from the date of delivery, to the original purchaser of the MKNA equipment (CUSTOMER), to be free from defects in material and workmanship; under normal use and with proper installation, maintenance and cleaning.

Additionally MKNA offers a LIMITED 10 YEAR WARRANTY on all equipment that MKNA is the original manufacturer of, to be free from defect and workmanship.¹

This warranty is extended by MKNA only to CUSTOMER, and is non-transferable. All warranty requests shall be made by CUSTOMER.

MKNA will replace or repair, at our factory or any other location we designate², any defective part within the warranty period and without charge. It is at MKNA's sole discretion whether to repair or replace. CUSTOMER will provide MKNA with a prompt written notice of the defect, including the serial number of the unit (when applicable) and the date of delivery.

At MKNA's request CUSTOMER will return all defective parts for evaluation at MKNA. MKNA will provide CUSTOMER with a return goods authorization number (RGA#). No parts will be returned without a RGA#. The RGA# must clearly be marked on all labels, packages and packing slips.

CUSTOMER shall pay all costs for packaging, shipping, duties and/or any other related costs in the sending or receiving of parts. CUSTOMER is responsible for all labor associated with sending or receiving of parts.

MKNA PROVIDES NO WARRANTY OF MERCHANTABILITY OR FITNESS FOR A PARTICULAR PURPOSE; UNLESS IT IS AGREED TO BY MKNA AND CUSTOMER IN WRITING PRIOR TO PLACEMENT OF ORDER. Such agreement requires approval of MKNA Management.

UNDER NO CIRCUMSTANCES SHALL MKNA BE HELD LIABLE FOR DAMAGES OR LIABILITY FOR LOSS OF PRODUCTION, PRODUCT, EQUIPMENT OR PROFITS OR LIABILITY FOR DIRECT, INCIDENTAL, INDIRECT, SPECIAL OR CONSEQUENTIAL DAMAGES OR ANY DAMAGES TO PERSONS OR PROPERTY, WHATSOEVER. CUSTOMER agrees that it is their sole remedy for liability of any kind, including negligence with respect to the equipment and services furnished by MKNA shall be limited to the remedies provided herein. This warranty shall not apply to any failure of the unit or its components caused by lack of maintenance and/or improper maintenance, incorrect adjustments, misuse or unreasonable use or exposure to chemicals and/or environments which the unit is not designed for. Unauthorized modification of the unit or the use of non-MKNA replacement parts and building components voids this warranty.

¹ The limited 10 year warranty does not apply to equipment and components manufactured by others. Such equipment and components are subject to any limitation contained in the original manufacturer's warranty and include, but are not limited to: bearings, belts, casters, controllers, motors and pneumatic devices.

² No work will be performed by MKNA or an MKNA factory authorized service representative at the site of installation unless in MKNA's opinion it is impractical for Customer to remove and return the defective part to MKNA's factory.

EXCEPT AS EXPRESSLY STATED HEREIN, THERE ARE NO WARRANTIES, EXPRESSED OR IMPLIED, BY OPERATION OF LAW OR OTHERWISE, OF THE EQUIPMENT OR SERVICES FURNISHED BY MKNA OR FACTORY AUTHORIZED SERVICE REPRESENTATIVE. THERE ARE NO WARRANTIES WHICH EXTEND BEYOND THE DESCRIPTION ON THE FACE HEREOF.

mk North America, Inc. reserves the right to change, modify or discontinue products and/or specifications with or without notice.

All of mk North America, Inc. products are covered by this warranty.

Technical Documentation

KFS-P 240.86

5 SAFETY REQUIREMENTS

5.1 Warnings - Safety Guidelines

READ AND UNDERSTAND ALL OF THESE WARNINGS PRIOR TO OPERATING EQUIPMENT.

CAUTION



Read this manual before operating conveyors.

CAUTION



Never operate or service equipment under the influence of drugs and/or alcohol.

CAUTION



Lock out power before servicing the conveyor.

WARNING



Do NOT operate conveyors without guards in place.

Severe injury can occur.

IMPORTANT



Conveyors must be installed so that they are square and level – across the belt. Failure to install conveyors correctly may cause premature equipment failure and/or product damage.

WARNING



Do not operate conveyors in an explosive environment.

DANGER



Moving equipment can cause severe injury or death.

Do NOT touch moving parts. Lock out power before servicing.

WARNING



Gearmotors will be hot. Do NOT touch.

Severe injury can occur.

DANGER



Climbing, sitting, walking or riding on the conveyor at any time could result in severe injury or death.

KEEP OFF!

DANGER



Always support conveyor sections prior to loosening stands or supports. Loosening stands or supports can cause the conveyor to fall creating a crush hazard.

NOTICE



All work should be done by qualified professionals. This includes electricians for all wiring.

Technical Documentation

KFS-P 240.86

6 WEAR ITEMS & MAINTENANCE - DRIVE & IDLER

6.1	Important Notes About Wear Items & Maintenance	11
6.2	KFS-P 2040.86 AC	12
6.3	KFS-P 2040.86 AS	14
6.4	KFS-P 2040.86 Idler	16

6 WEAR ITEMS & MAINTENANCE - DRIVE & IDLER (CONT.)

6.1 Important Notes About Wear Items & Maintenance

The following information regarding life of the wear items and service or adjustment intervals of the functional elements are only GUIDELINES. Conveyors are application-specific products whose life expectancy can vary depending on their relative loads and speeds, and which can be significantly influenced by environmental factors.

- All moving components and screw connections should be checked every 6 months.
- All safety-relevant components should be part of a regularly scheduled weekly inspection
- The proper function of these components must be confirmed at all times.
- Do NOT operate conveyors if safety-relevant components are damaged or missing.
- All parts which contact the product should be cleaned weekly (example: belt).
- Belts require little special care.
- Blow off debris from belts with structured surfaces using compressed air.

Technical Documentation KFS-P 240.86

6 WEAR ITEMS & MAINTENANCE - DRIVE & IDLER (CONT.)

6.2 KFS-P 2040.86 AC

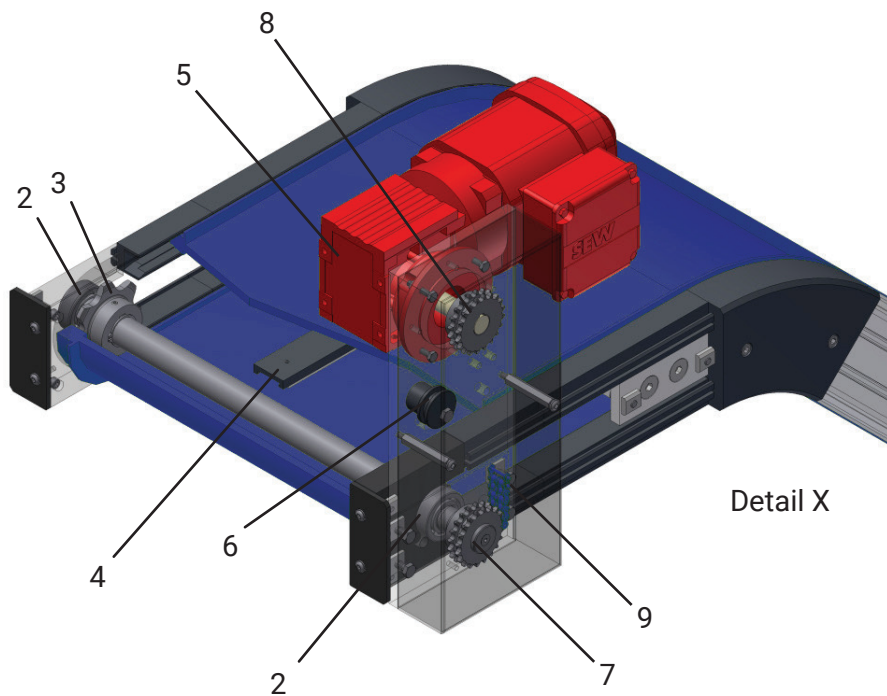
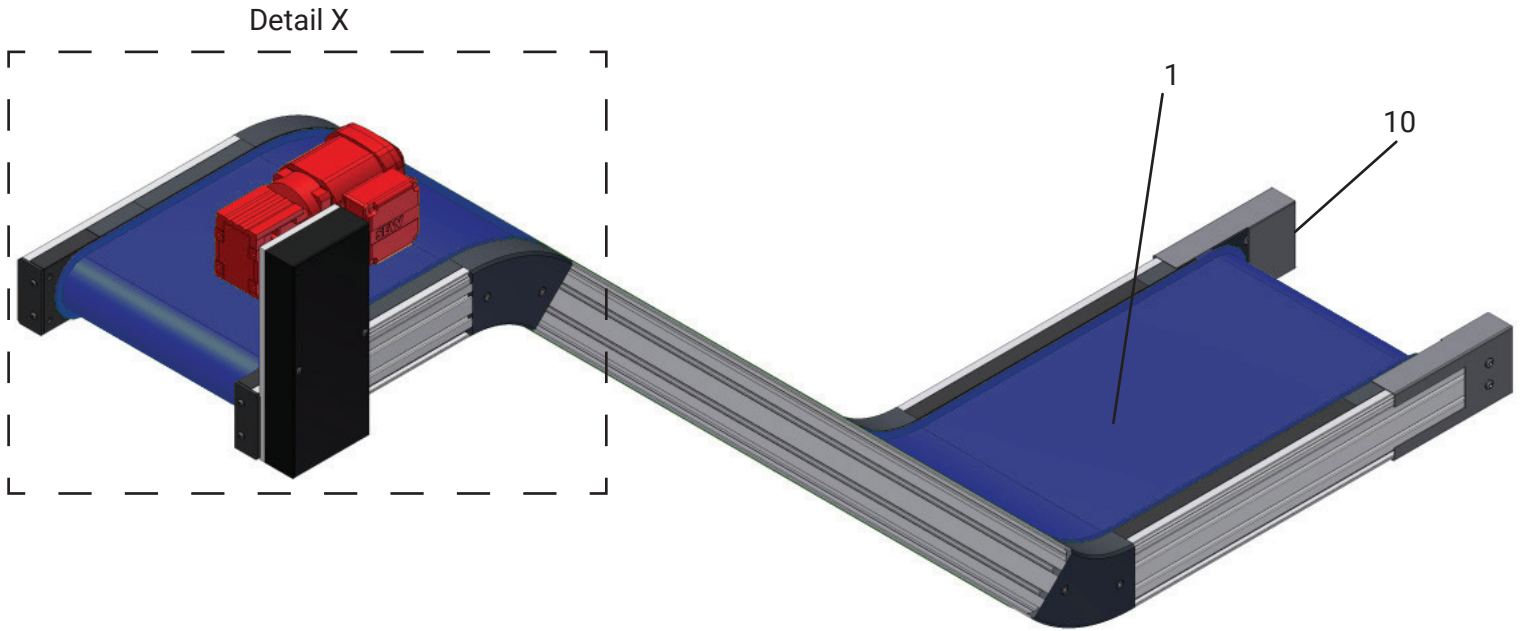

NOTE: Not all items shown in all views for clarity.

(Cont.)

6 WEAR ITEMS & MAINTENANCE - DRIVE & IDLER

(CONT.)

6.2 KFS-P 2040.86 AC (Cont.)

Maintenance Work for KFS-P 2040.86 AC

Position	Description	Action*	Interval in Hours (Months)	Lubrication
1	Steel Belt	I, C	500 Hours (Max. 3 Months)	
		R	If visible wear is noticed	
2	Bearing	I, C	1,000 Hours (Max. 6 Months)	
3	Drive Sprocket	I, C	500 Hours (Max. 3 Months)	
		R	If wear visible	
4	Wear Strip	I, C	1,000 Hours (Max. 6 Months)	
		R	If wear visible	
5	Gearmotor	I, C	Service & maintenance per manufacturer's documentation	
6	Tensioning Roller	I, C	500 Hours (Max. 3 Months)	
		R	If wear is noticeable	
7 & 8	Drive Train Sprockets 7: Conveyor 8: Motor	I, C, T	500 Hours (Max. 3 Months)	
		R	When changing the chain	
9	Drive Train Chain	I, C, T, L	500 Hours (Max. 3 Months)	S014
		R	If chain stretch is greater than 3%	
10	Idler Assembly	See Section 6.4 for details		

* LEGEND: *Inspect, Replace, Tension, Clean, Lubricate (grease).*

Wear Items for KFS-P 2040.86 AC

Position	Part Number
All	Inquire with mk North America, Inc.

NOTE: *For adjusting the chain tensioning, please see the related section for details. When cleaning the chain, avoid any harsh chemicals or detergents.*

Technical Documentation KFS-P 240.86

6 WEAR ITEMS & MAINTENANCE - DRIVE & IDLER (CONT.)

6.3 KFS-P 2040.86 AS

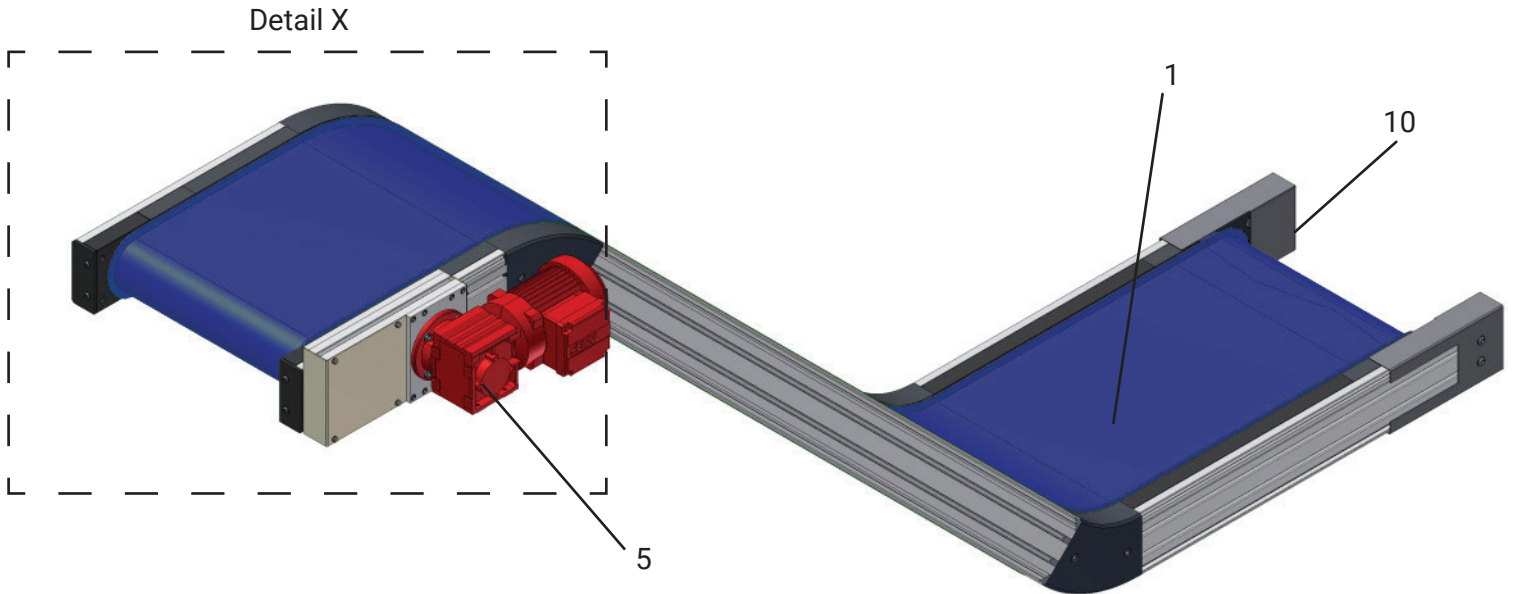

Detail X
Motor Not Shown

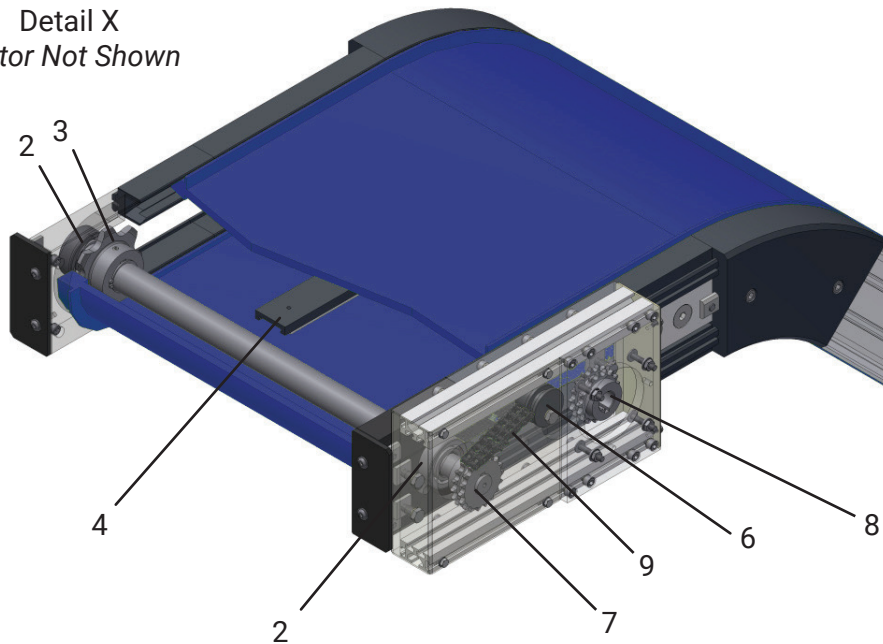

NOTE: Not all items shown in all views for clarity.

(Cont.)

6 WEAR ITEMS & MAINTENANCE - DRIVE & IDLER

(CONT.)

6.3 KFS-P 2040.86 AS (Cont.)

Maintenance Work for KFS-P 2040.86 AS

Position	Description	Action*	Interval in Hours (Months)	Lubrication
1	Steel Belt	I, C	500 Hours (Max. 3 Months)	
		R	If visible wear is noticed	
2	Bearing	I, C	1,000 Hours (Max. 6 Months)	
		R	If wear visible	
3	Drive Sprocket	I, C	500 Hours (Max. 3 Months)	
		R	If wear visible	
4	Wear Strip	I, C	1,000 Hours (Max. 6 Months)	
		R	If wear visible	
5	Gearmotor	I, C	Service & maintenance per manufacturer's documentation	
6	Tensioning Roller	I, C	500 Hours (Max. 3 Months)	
		R	If wear is noticeable	
7 & 8	Drive Train Sprockets 7: Conveyor 8: Motor	I, C, T	500 Hours (Max. 3 Months)	
		R	When changing the chain	
9	Drive Train Chain	I, C, T, L	500 Hours (Max. 3 Months)	SO14
		R	If chain stretch is greater than 3%	
10	Idler Assembly	See Section 6.4 for details		

* LEGEND: Inspect, Replace, Tension, Clean, Lubricate (grease).

Wear Items for KFS-P 2040.86 AS

Position	Part Number
All	Inquire with mk North America, Inc.

NOTE: For adjusting the chain tensioning, please see the related section for details.
When cleaning the chain, avoid any harsh chemicals or detergents.

Technical Documentation KFS-P 240.86

6 WEAR ITEMS & MAINTENANCE - DRIVE & IDLER (CONT.)

6.4 KFS-P 2040.86 Idler

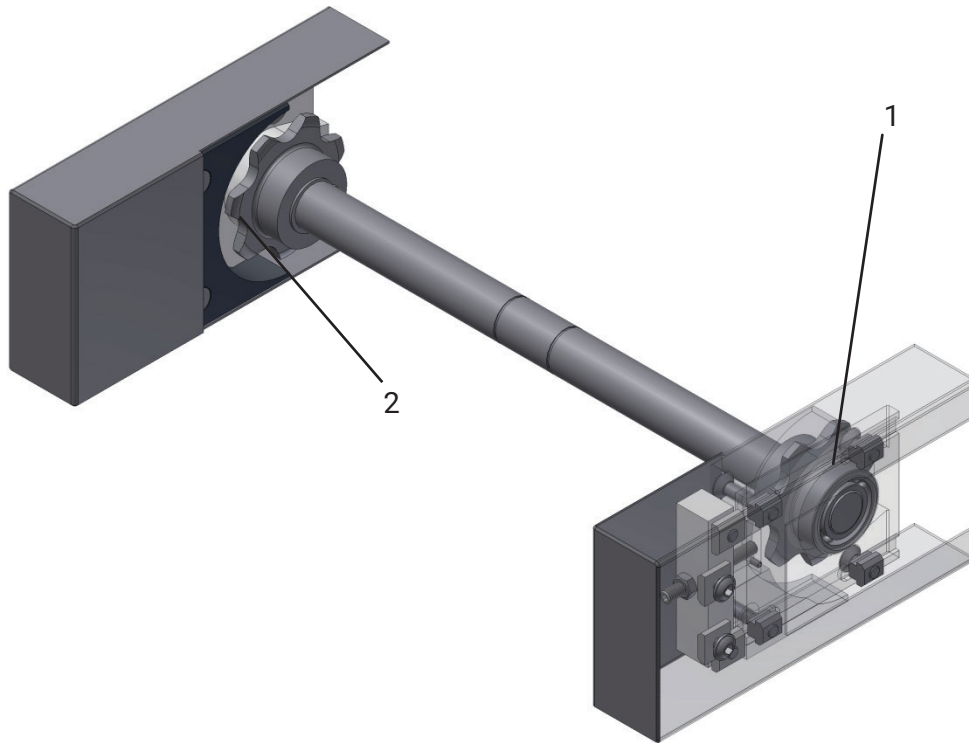

Maintenance Work for KFS-P 2040.86 Idler

Position	Description	Action*	Interval in Hours (Months)	Lubrication
1	Bearing	I, C	1,000 Hours (Max. 6 Months)	
		R	If wear visible	
2	Drive Sprocket	I, C	500 Hours (Max. 3 Months)	
		R	If wear visible	

* LEGEND: Inspect, Replace, Tension, Clean, Lubricate (grease).

NOTE: Not all items shown in all views for clarity.

(Cont.)

7 CONVEYOR MAINTENANCE - DRIVE CHAIN



All work to be performed by qualified personnel only.

Conveyor power **must be disconnected before performing maintenance.**

7.1	Warnings	17
7.2	Tensioning the Drive Chain KFS-P 2040.86 AC	18
7.3	Greasing the Drive Chain KFS-P 2040.86 AC	19
7.4	Tensioning the Drive Chain KFS-P 2040.86 AS	20
7.5	Greasing the Drive Chain KFS-P 2040.86 AS	21

7.1 Warnings

Risk of Injury!

- The unintentional activation of the mk product during maintenance work may lead to injuries.
- Before beginning maintenance work, disconnect the mk product from all power sources and secure it against being switched on by mistake – LOCK OUT POWER.
- Upon completing the maintenance work, all parts that contribute to safety must be reinstalled in their specified designated position.

Technical Documentation

KFS-P 240.86

7 CONVEYOR MAINTENANCE - DRIVE CHAIN

(CONT.)

7.2 Tensioning the Drive Chain KFS-P 2040.86 AC

1. Remove cap nuts (1) and remove chain guard (2).

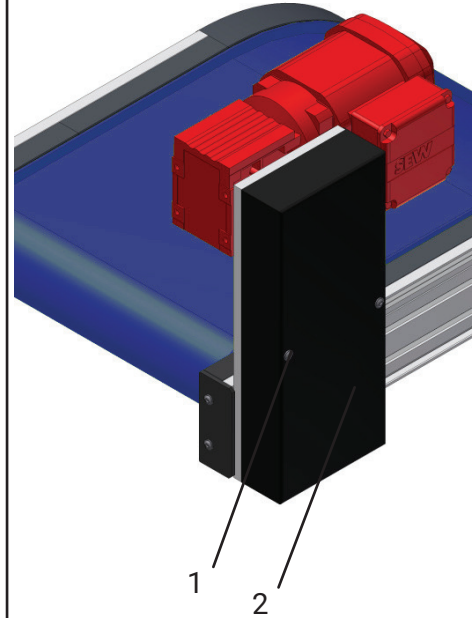

1. Tension the drive chain (3) using the tensioning element (4).

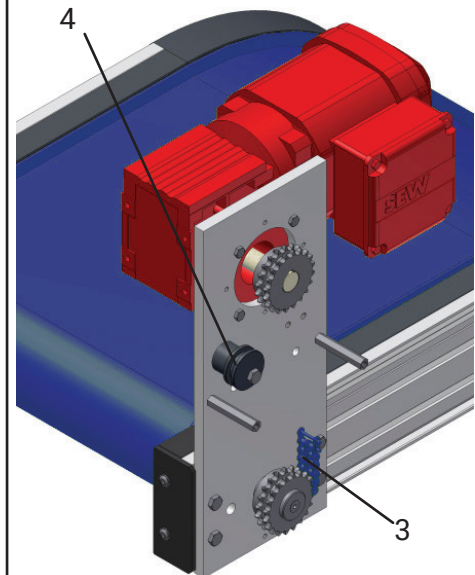

Note: Reassemble in reverse order; ensuring all screws are tight and all guards are in place before operating.

7 CONVEYOR MAINTENANCE - DRIVE TRAIN

(CONT.)

7.2 Tensioning the Drive Chain KFS-P 2040.86 AC

IMPORTANT NOTES

1. Do not over tension the drive chain. It must always have between 2 to 6 mm of play on the return strand. (See figure on right)
2. The drive sprocket wheels must always be flush with each other.
3. Replace the chain guard once the maintenance work is complete.

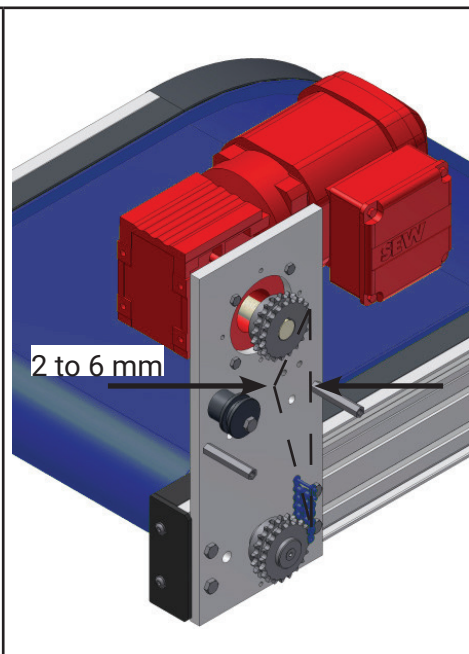

7.3 Greasing the Drive Chain KFS-P 2040.86 AC

1. Use lubricant SO14 to lubricate the drive chain (3) according to the maintenance instructions.
2. The lubricant must be applied on the edge of the nut using a brush to ensure that it enters into the chain joint.
3. Replace the chain guard once the maintenance work is complete.

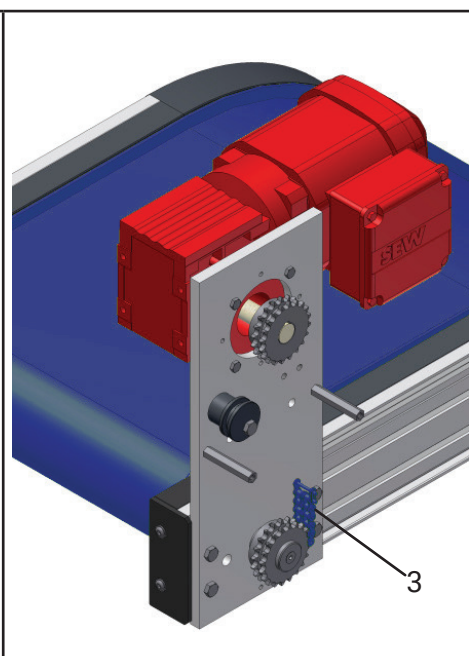

Note: Reassemble in reverse order; ensuring all screws are tight and all guards are in place before operating.

Technical Documentation

KFS-P 240.86

7 CONVEYOR MAINTENANCE - DRIVE CHAIN

(CONT.)

7.4 Tensioning the Drive Chain KFS-P 2040.86 AS

1. Remove screws (1) and remove chain guard (2).

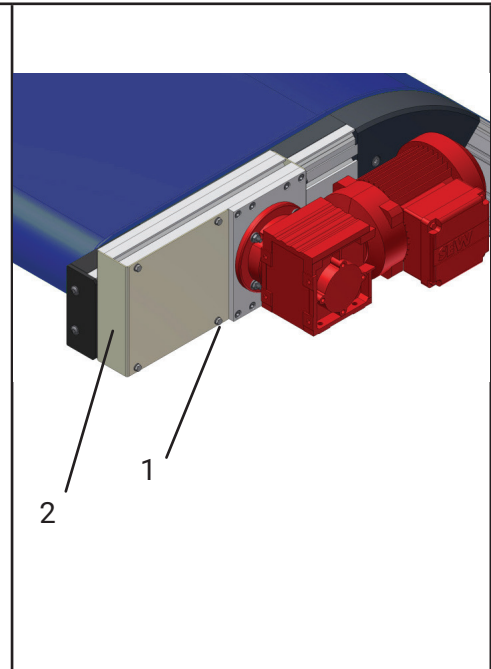

2. Tension the drive chain (3) using the tensioning element (4).

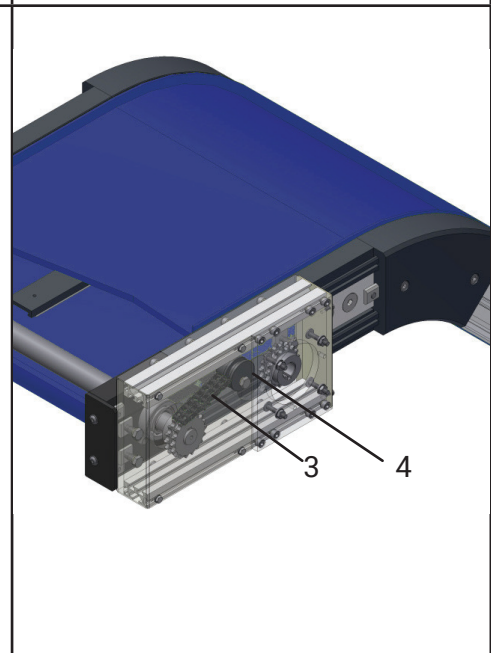

Note: Reassemble in reverse order; ensuring all screws are tight and all guards are in place before operating.

7 CONVEYOR MAINTENANCE - DRIVE TRAIN

(CONT.)

7.4 Tensioning the Drive Chain KFS-P 2040.86 AS

IMPORTANT NOTES

3. Do not over tension the drive chain. It must always have between 2 to 6 mm of play on the return strand. (See figure on right)
4. The drive sprocket wheels must always be flush with each other.
6. Replace the chain guard once the maintenance work is complete.

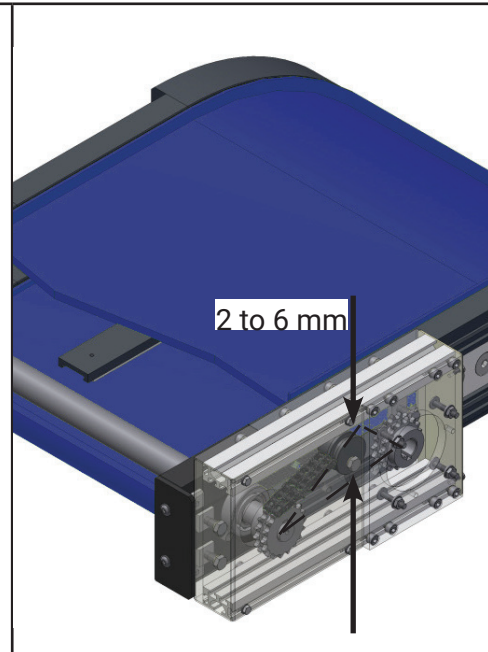

7.5 Greasing the Drive Chain KFS-P 2040.86 AS

1. Use lubricant S014 to lubricate the drive chain (3) according to the maintenance instructions.
2. The lubricant must be applied on the edge of the nut using a brush to ensure that it enters into the chain joint.
3. Replace the chain guard once the maintenance work is complete.

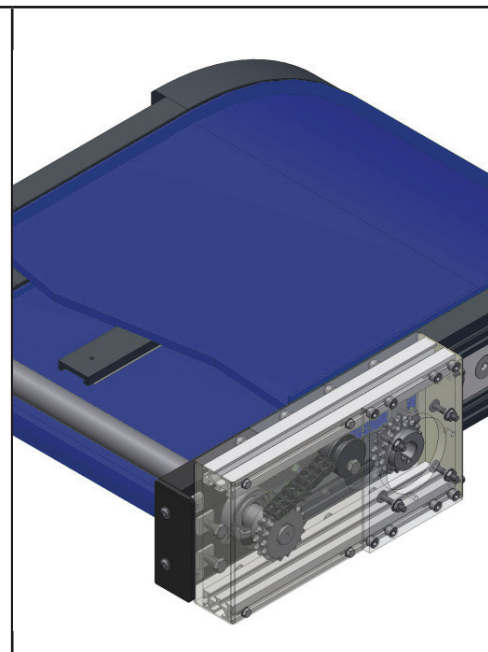

Note: Reassemble in reverse order; ensuring all screws are tight and all guards are in place before operating.

Technical Documentation

KFS-P 240.86

8 STEEL BELT MAINTENANCE



All work to be performed by qualified personnel only.

Conveyor power must be disconnected before performing maintenance.

8.1	Steel Belt Maintenance General Notes	23
8.2	Warnings	23
8.3	Steel Belt Maintenance Trouble Shooting	23
8.4	Steel Belt Tensioning	24
8.5	Belt Replacement	26

8 STEEL BELT MAINTENANCE

(CONT.)

8.1 Steel Belt Maintenance General Notes

The following general rules apply:

- After a downtime of more than 2 hours, allow the hinged plate belt to run for 5 to 10 minutes, of normal operation, so that it can adapt before running as part of the production line.
- All rollers and sprockets must be clean. Replace damaged or heavily worn components.
- The teeth on the sprockets must always positively engage with the hinged plate belt.
- Clean with non-caustic solutions. Do not allow belt to remain wet.

8.2 Warnings

Risk of injury!

- The unintentional activation of the mk product during maintenance work may lead to injuries.
- Before beginning maintenance work, disconnect the mk product from all power sources and secure it against being switched on by mistake – LOCK OUT POWER.
- Upon completing the maintenance work, all parts that contribute to safety must be reinstalled in their specified designated position.

8.3 Steel Belt Maintenance Trouble Shooting

Tension to High

- Loud operating noises.
- The sprockets will sustain permanent damage in the long term.
- Correct as soon as possible.

Tension to Low

- The hinged plate belt slips.
- The sprocket wheels no longer positively engage with the hinges on the underside on the belt.
- Correct as soon as possible.

Technical Documentation

KFS-P 240.86

8 STEEL BELT MAINTENANCE

(CONT.)

8.4 Steel Belt Tensioning

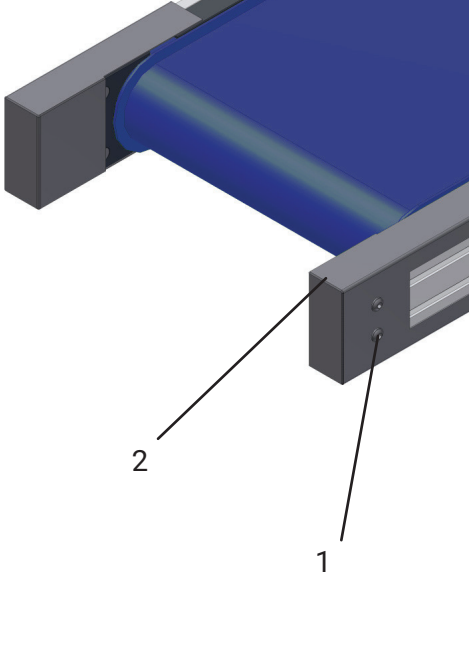
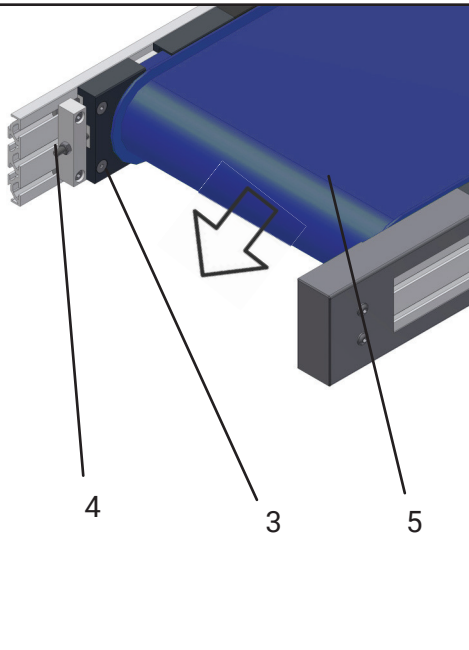
<ol style="list-style-type: none">1. At the idler end loosen screws (1) and remove the protective cover (2) - on both sides of the conveyor frame.	 <p>The diagram shows a close-up of the idler end of a conveyor. A blue steel belt is shown passing over a grey idler roller. On the right side of the frame, there is a grey protective cover (2) and two screws (1) that hold it in place. Lines connect the numbers 1 and 2 to their respective parts in the diagram.</p>
<ol style="list-style-type: none">2. Loosen screws (3) and apply tension the steel belt (5) by adjusting the tensioning screw (4) to pull the idler assembly in the direction of the arrow.3. Tighten screws (3).4. Replace the protective cover, using the reverse of the steps above.	 <p>The diagram shows the same conveyor assembly from a different angle. It highlights the tensioning screw (4) and the screws (3) that hold the idler assembly. A white arrow points to the right, indicating the direction to pull the idler assembly. The blue steel belt (5) is also shown. Lines connect the numbers 3, 4, and 5 to their respective parts in the diagram.</p>

Note: Reassemble in reverse order; ensuring all screws are tight and all guards are in place before operating.

8 STEEL BELT MAINTENANCE

(CONT.)

8.5 Steel Belt Replacement

1. At the **IDLER** end loosen screws (1) and remove the protective cover (2) - on both sides of the conveyor frame.

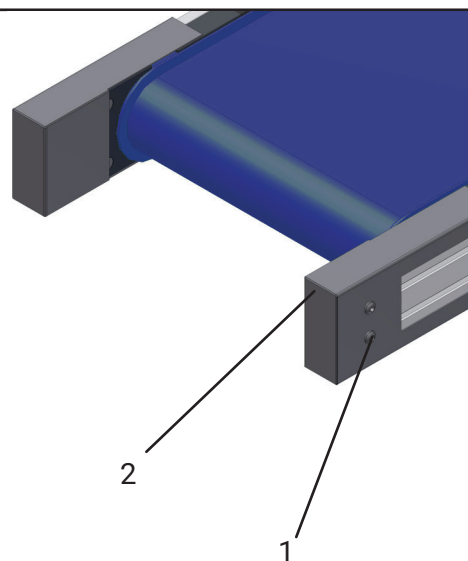

2. Loosen screws (3) and reduce tension the steel belt (5) by adjusting the tensioning screw (4) and pushing the idler assembly in the direction of the arrow.
3. Tighten screws (3).

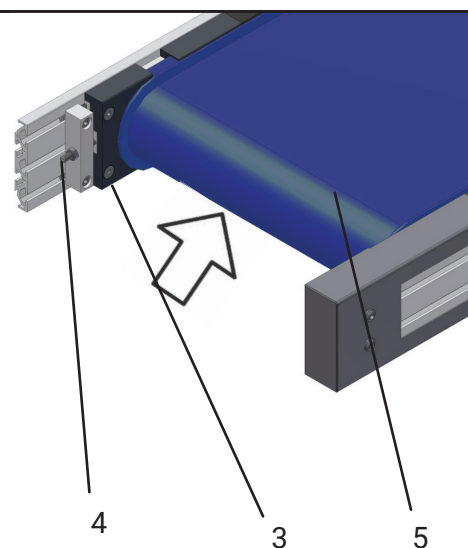

Note: Reassemble in reverse order; ensuring all screws are tight and all guards are in place before operating.

Technical Documentation

KFS-P 240.86

8 STEEL BELT MAINTENANCE

(CONT.)

8.5 Steel Belt Replacement

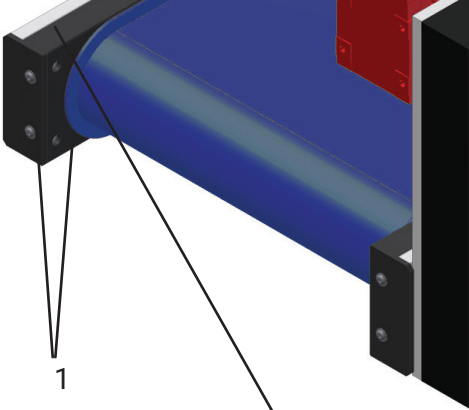
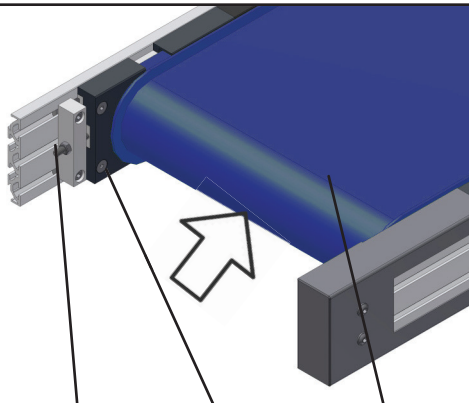
<p>1. At the DRIVE loosen screws (1) and remove the protective cover (2).</p>	 <p>The diagram shows a blue steel belt on a drive pulley. Two screws, labeled '1', are shown being loosened from a black protective cover, labeled '2', which is partially detached from the pulley.</p>
<p>2. Loosen screws (3) and apply tension the steel belt (5) by adjusting the tensioning screw (4) to pull the idler assembly in the direction of the arrow.</p> <p>3. Tighten screws (3).</p> <p>4. Replace the protective cover, using the reverse of the steps above.</p>	 <p>The diagram shows the steel belt (5) being tensioned. A tensioning screw (4) is being adjusted to pull the idler assembly towards the right, as indicated by a white arrow. Screws (3) are shown being loosened to allow for this adjustment.</p>

Note: Reassemble in reverse order; ensuring all screws are tight and all guards are in place before operating.

8 STEEL BELT MAINTENANCE

(CONT.)

8.5 Steel Belt Replacement

IMPORTANT NOTE

Clamp the belt down before proceeding, this will help prevent slipping and damage and/or injury.

5. Position the hinged steel belt so that you can easily access the side, and the connecting rods.
6. Remove the one of the connection rods (7).
7. The belt is now open ended, the clamps can carefully be removed and the belt can be threaded out of the conveyor.
8. Thread the new belt through the conveyor frame, ensuring the teeth of the sprockets align with the hinges on the underside of the belt.
9. Follow directions in Section 8.4 to tension the belt.
10. Tension before operating.
11. Re-tension after 100 hours of run time.

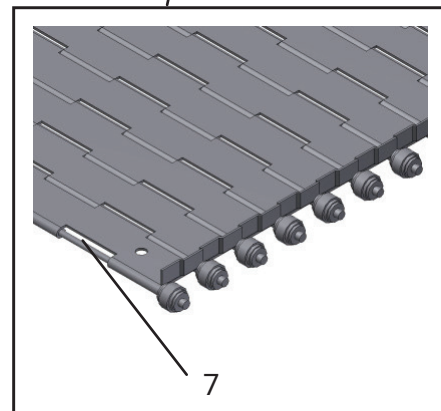
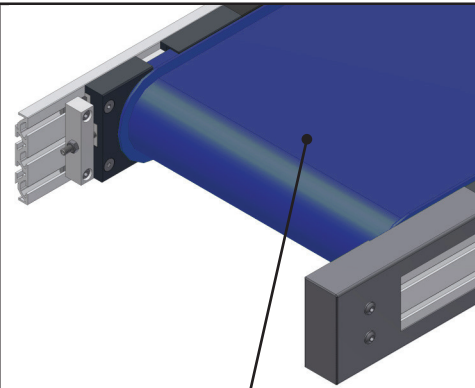

Note: Reassemble in reverse order; ensuring all screws are tight and all guards are in place before operating.

Technical Documentation

KFM-P 2040.86

9 CONTACT INFORMATION



sales@mknorthamerica.com
spareparts@mknorthamerica.com
service@mknorthamerica.com



(860) 769-5500

Technical Documentation
KFS-P 2040.86
Steel-Hinged-Belt Conveyor

mk North America, Inc.
an mk Technology Group Company
105 Highland Park Drive
Bloomfield, CT 06002, USA
Phone: (860) 769-5500

www.mknorthamerica.com
sales@mknorthamerica.com

All rights reserved, information subject to change without notice. © 2024 mk North America, Inc.

REV. 2024.03.11