



»» For horizontal conveying around corners. ««

The KGF-P 2040 conveyor system is based on Series 40 profiles and is compatible with all mk conveyor systems. The t-slots running along the outer radius (10 mm slot width based on our profile technology) allow you to easily connect additional accessories such as side rails, sensors, and so on. The profile design provides a torsion-resistant structure with good load-bearing properties. The values for the total load, speeds, and so on, specified below are directly related to this design and may vary as a result.

The conveyor is equipped with a $\varnothing 20$ rolling knife edge that allows even small products to be reliably transferred to the next system. Belt tensioning is handled by an automatic tensioning device that is integrated in the tail, which keeps the conveyor's outer dimensions constant. For options with a standard motor, the compact lower belt drive ensures that there are no obstructing edges.

Benefits of the KGF-P 2040

- Horizontal transport on a 90° and 180° curve
- Compatible with all mk conveyor systems
- $\varnothing 20$ rolling knife edge ensures reliable transport of small product
- Integrated tensioning mechanism that automatically tensions the belt
- Lower belt drive leaves no obstructing edges
- Flexible operation in reverse and accumulation modes

Cross Section

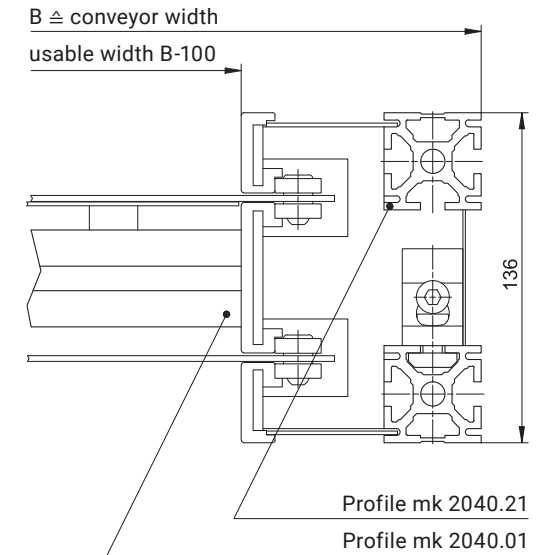



BC – Lower belt drive, standard

B20.40.020 (90°) | B20.40.021 (180°)

With this conveyor, mk offers the BC drive version with a usable width of 300, 400, 500 and 600 mm for 90° and 180° conveying radii. The compact conveyor frame design makes it easy to integrate the conveyor into existing systems. The \varnothing 55 mm driving roller ensures excellent transmission of the motor power.

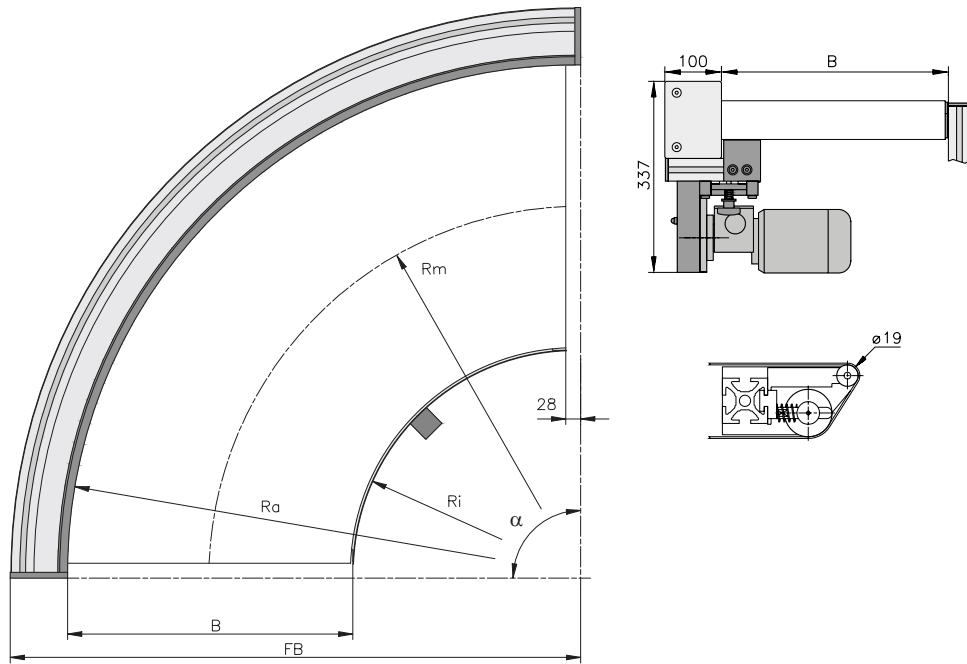

Technical data

Conveying angle	90° and 180°, others on request
Usable width B	300 with Ra=600 mm, Ri=300 mm, FB=706 400 with Ra=900 mm, Ri=500 mm, FB=1006 500 at Ra=900 mm, Ri=400 mm, FB=1006 600 at Ra=900 mm, Ri=300 mm, FB=1006
Drive location	below
Drive and speed	5 to 30 m/min at Rm, others on request
Stands	standard design or with belt replacement aid
Load capacity	depending on conveyor radius and conveyed product, up to 30 kg
Belts	

from p. 98

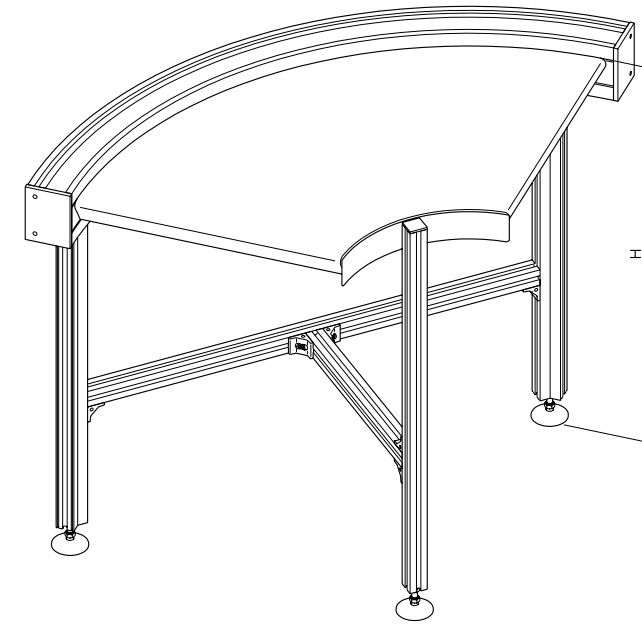

Radius of 90° Curve Versions
B20.40.020

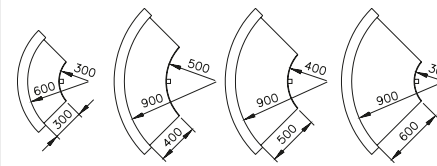

Radius of 180° Curve Versions
B20.40.021

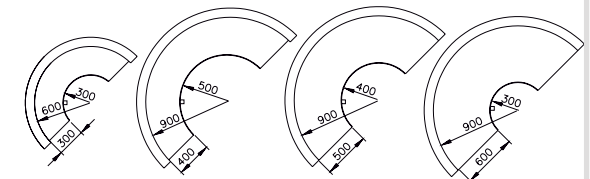

Sample order

- KGF-P 2040
- Ra 900/Ri 500 version
- Speed of 15 m/min
- Conveyor width B = 400 mm
- Belt type
- Stand, with or without
- Belt replacement support
- Conveyor height H = 800 mm

Type designation

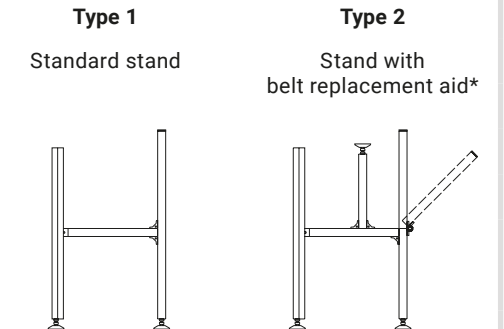

*With usable width B = 400 mm or wider



Curved belt conveyor KGF-P 2040 with centre drive BC and stand type 1



Curved belt conveyor KGF-P 2040 with centre drive BI and rolling knife edge



180° curved belt conveyor KGF-P 2040 without internal radius



180° curved belt conveyor KGF-P 2040 with 300 mm internal radius



Curved belt conveyor KGF-P 2040 with internal radius R=300 mm and stand type 2



180° curved belt conveyor KGF-P 2040 with side rail on internal radius



Curved belt conveyor KGF-P 2040 with rolls for transfer to the belt conveyor without a knife edge



Curved belt conveyor KGF-P 2040 with height-adjustable, movable frame

Custom applications from page 404