



Technical  
Documentation

# SPU 2040 RECIRCULATING PALLET CONVEYOR SYSTEMS

Each serial number is unique to that specific conveyor and provides mk North America with complete order details.

The conveyor serial number is located on the frame at the drive end of the conveyor. See section 2 for more details.

---

1	General Information	3
2	Serial Number Label	4
3	Conveyor Description	5
4	Warranty Information	7
5	Safety Requirements	8
6	Wear Items & Maintenance	10
7	Conveyor Chain Maintenance - Tensioning & Tracking	32
8	Contact Information	35

## 1 GENERAL INFORMATION

### 1.1 Foreword

Congratulations on purchasing a conveyor from mk North America, Inc., a leading manufacturer of quality low profile conveyors. Our more than 30 years experience in material handling allows us to offer robust solutions with long life and reliable operation. We strive to make the best products in the industry even better and we are committed to making sure our customers get top notch support before, during, and after each and every sale.

### 1.2 The importance of reading your manual

Inside this manual you will find the instructions on how to set up and maintain your mk conveyor properly, as well as maximize its performance. Please take the time to read this manual and familiarize yourself with these set up and maintenance instructions. These instructions will help assure a long product life that requires a minimum amount of service and keeps your conveyor working at its maximum capacity.

### 1.3 If you need assistance

If you need assistance there are a variety of ways to get it. You can contact our customer service team Monday through Friday, 8am-5pm (Eastern Time) at (860) 769-5500. You can also visit our website for additional information and technical documentation at [www.mknorthamerica.com](http://www.mknorthamerica.com). In addition, your local representative can provide support in many instances.

### 1.4 When your shipment arrives

- 1) Check your shipment
  - a) If you have not already done so, visually inspect the shipping crate/container for any damage caused during shipment.
  - b) Carefully unpack the crate/container making sure to inspect the components for damage that may have occurred inside the packaging materials.
  - c) If you find any damage, please contact the carrier and mk North America, Inc.
  - d) Lastly, check the contents against the packing slip provided by mk for any discrepancies. If you should find any, please contact mk North America, Inc.
- 2) Locate your ordered items
  - a) Each mk conveyor will ship in its own custom built container, carefully packaged in the most economical way.
  - b) Review the packing slip against your Purchase Order.

# Technical Documentation SPU 2040



## 2 SERIAL NUMBER LABEL

• The conveyor's serial number is located on the frame at the drive end of the conveyor.



### Type:

This description refers to the type of unit that is associated with the particular serial number. The type should NOT be substituted for the serial number when inquiring.

### Serial #:

This number is unique to this item. With this number we can access all of the original order details.

### Drawing #:

This number, if applicable, refers to the specific drawing that was created for this unit.

### Date:

This is the date that the unit was scheduled to ship.

### CO#:

This is the customer order number in which this unit was built. This is an mk North America, Inc. internal number. This number is also referenced on any related invoices, etc.

### Scan for Documentation:

Scanning this QR code will bring you to a webpage specific for the conveyor on this order. From here you can access drawings and spare parts.

## 3 CONVEYOR DESCRIPTION

### 3.1 Explaining the conveyor **TYPE**.

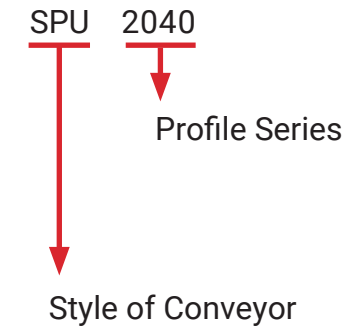

### Style of Conveyor

DGF (Doppel-Gurt Foerderer) Dual-Belt Conveyor

GUF (Gurt Foerderer) Belt Conveyor

KFG (Knickfoerderer Gurt) Bent "Gooseneck" Belt Conveyor

KFM (Knickförder Modular) Bent "Gooseneck" Plastic Modular Belt Conveyor

KGf (Kurvengurt Foerderer) Curve Belt Conveyor

KMF (Kurvengängiges Modulband) Curved Modular Belt Conveyor

KTF (Kettengurt Foerderer) Chain Conveyor

MBF (Modulband Foerderer) Modular Belt Conveyor

RBM (Rollenbahn Motor) Motorized Roller Conveyor

RBS (Rollerbahn Schwerkraft) Idler Roller Conveyor

RBT (Rollenbahn Tangentialkette) Drive Roller Conveyor

SBF (Scharnierband Foerderer) Hinged Belt Conveyor

SPU (Staufaehiges Pallettenumlaufsystem) Continuous Motion Pallet Conveyor

SRF (Staurollen Foerderer) Accumulating Roller Conveyor

TKU (Taktkettenförderer) Timing Chain Conveyor

ZRF (Zahnriemen Förderer) Timing Belt Conveyor

3 CONVEYOR DESCRIPTION (CONT.)

3.2 Conveyor Components

The SPU 2040 has many typical conveyor components. Below is a description of the basic parts and options for the SPU 2040 conveyor. The items you receive will vary based on your actual purchase order. Items may appear different on your model based on your particular order requirements. Consult your approval drawing for specific items included in your order.

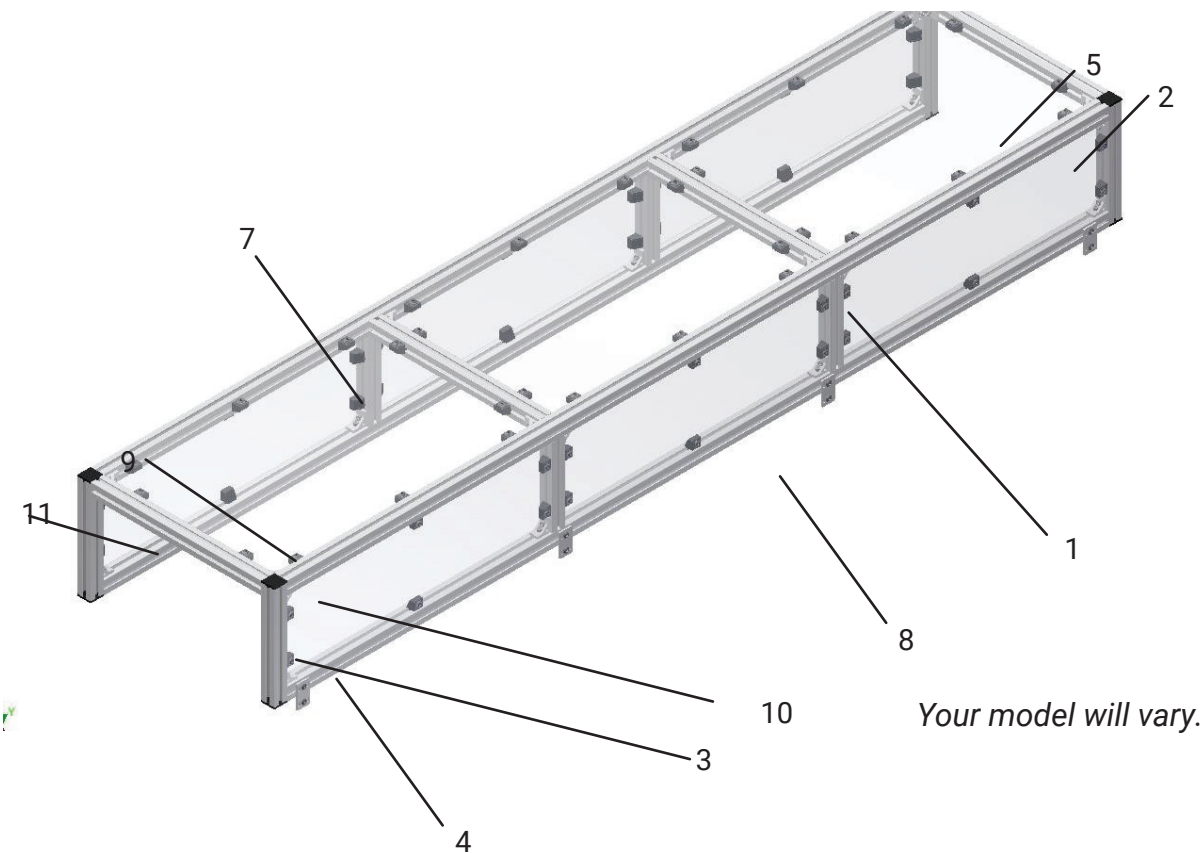

**Typical Components**

- |                                     |  |
|-------------------------------------|--|
| 1) Conveyor Frame                   | 8) Support Stand                         |
| 2) Idler End                        | 9) Pallet                                |
| 3) Drive End                        | 10) Pallet Separator (Location may vary) |
| 4) Gearmotor                        | 11) Locating Device (Location may way)   |
| 5) Chain                            |  |
| 6) Controller (Not Shown, Optional) |  |
| 7) Cover (Optional)                 |  |

4 WARRANTY INFORMATION

Warranty

mk North America, Inc. (MKNA) offers a COMPLETE ONE YEAR WARRANTY from the date of delivery, to the original purchaser of the MKNA equipment (CUSTOMER), to be free from defects in material and workmanship; under normal use and with proper installation, maintenance and cleaning.

Additionally MKNA offers a LIMITED 10 YEAR WARRANTY on all equipment that MKNA is the original manufacturer of, to be free from defect and workmanship.<sup>1</sup>

This warranty is extended by MKNA only to CUSTOMER, and is non-transferable. All warranty requests shall be made by CUSTOMER.

MKNA will replace or repair, at our factory or any other location we designate<sup>2</sup>, any defective part within the warranty period and without charge. It is at MKNA's sole discretion whether to repair or replace. CUSTOMER will provide MKNA with a prompt written notice of the defect, including the serial number of the unit (when applicable) and the date of delivery.

At MKNA's request CUSTOMER will return all defective parts for evaluation at MKNA. MKNA will provide CUSTOMER with a return goods authorization number (RGA#). No parts will be returned without a RGA#. The RGA# must clearly be marked on all labels, packages and packing slips.

CUSTOMER shall pay all costs for packaging, shipping, duties and/or any other related costs in the sending or receiving of parts. CUSTOMER is responsible for all labor associated with sending or receiving of parts.

MKNA PROVIDES NO WARRANTY OF MERCHANTABILITY OR FITNESS FOR A PARTICULAR PURPOSE; UNLESS IT IS AGREED TO BY MKNA AND CUSTOMER IN WRITING PRIOR TO PLACEMENT OF ORDER. Such agreement requires approval of MKNA Management.

UNDER NO CIRCUMSTANCES SHALL MKNA BE HELD LIABLE FOR DAMAGES OR LIABILITY FOR LOSS OF PRODUCTION, PRODUCT, EQUIPMENT OR PROFITS OR LIABILITY FOR DIRECT, INCIDENTAL, INDIRECT, SPECIAL OR CONSEQUENTIAL DAMAGES OR ANY DAMAGES TO PERSONS OR PROPERTY, WHATSOEVER. CUSTOMER agrees that it is their sole remedy for liability of any kind, including negligence with respect to the equipment and services furnished by MKNA shall be limited to the remedies provided herein. This warranty shall not apply to any failure of the unit or its components caused by lack of maintenance and/or improper maintenance, incorrect adjustments, misuse or unreasonable use or exposure to chemicals and/or environments which the unit is not designed for. Unauthorized modification of the unit or the use of non-MKNA replacement parts and building components voids this warranty.

<sup>1</sup> The limited 10 year warranty does not apply to equipment and components manufactured by others. Such equipment and components are subject to any limitation contained in the original manufacturer's warranty and include, but are not limited to: bearings, belts, casters, controllers, motors and pneumatic devices.

<sup>2</sup> No work will be performed by MKNA or an MKNA factory authorized service representative at the site of installation unless in MKNA's opinion it is impractical for Customer to remove and return the defective part to MKNA's factory.

EXCEPT AS EXPRESSLY STATED HEREIN, THERE ARE NO WARRANTIES, EXPRESSED OR IMPLIED, BY OPERATION OF LAW OR OTHERWISE, OF THE EQUIPMENT OR SERVICES FURNISHED BY MKNA OR FACTORY AUTHORIZED SERVICE REPRESENTATIVE. THERE ARE NO WARRANTIES WHICH EXTEND BEYOND THE DESCRIPTION ON THE FACE HEREOF.

mk North America, Inc. reserves the right to change, modify or discontinue products and/or specifications with or without notice.

All of mk North America, Inc. products are covered by this warranty.

5 SAFETY REQUIREMENTS

5.1 Warnings - Safety Guidelines

**READ AND UNDERSTAND ALL OF THESE WARNINGS PRIOR TO OPERATING EQUIPMENT.**

**CAUTION**



Read this manual before operating conveyors.

**CAUTION**



Never operate or service equipment under the influence of drugs and/or alcohol.

**CAUTION**



Lock out power before servicing the conveyor.

**WARNING**



Do NOT operate conveyors without guards in place.  
Severe injury can occur.

**IMPORTANT**



Conveyors must be installed so that they are square and level – across the belt. Failure to install conveyors correctly may cause premature equipment failure and/or product damage.

**WARNING**



Do not operate conveyors in an explosive environment.

**DANGER**



Moving equipment can cause severe injury or death.  
Do NOT touch moving parts. Lock out power before servicing.

**WARNING**



Garmotors will be hot. Do NOT touch.  
Severe injury can occur.

**DANGER**



Climbing, sitting, walking or riding on the conveyor at any time could result in severe injury or death.  
**KEEP OFF!**

**DANGER**



Always support conveyor sections prior to loosening stands or supports. Loosening stands or supports can cause the conveyor to fall creating a crush hazard.

5 SAFETY REQUIREMENTS

(CONT.)

**NOTICE**



All work should be done by qualified professionals. This includes electricians for all wiring.

## 6 WEAR ITEMS & MAINTENANCE

---

6.1	Important Notes About Wear Items & Maintenance	11
6.2A	SPU 2040 Drive AF	12
6.2B	SPU 2040 Drive AC	14
6.3	SPU 2040 Idler, with Pneumatic Tensioner	16
6.4	SPU 2040 Locating Device	20
6.5	SPU 2040 Pallet Separator	22
6.5	SPU 2040 Stop	24
6.6	SPU 2040 Pallet	26
6.7	SPU 2040 Frame and Chain	27
6.9	SPU 2040 Cover (Optional Item)	27

## 6 WEAR ITEMS & MAINTENANCE

---

(CONT.)

### 6.1 Important Notes About Wear Items & Maintenance

The following information regarding life of the wear items and service or adjustment intervals of the functional elements are only GUIDELINES. Conveyors are application-specific products whose life expectancy can vary depending on their relative loads and speeds, and which can be significantly influenced by environmental factors.

- All moving components and screw connections should be checked every 6 months.
- All safety-relevant components should be part of a regularly scheduled weekly inspection.
- The proper function of these components must be confirmed at all times.
- Do NOT operate conveyors if safety-relevant components are damaged or missing.
- All parts which contact the product should be cleaned weekly (example: chain).
- Chains require little special care.
- Remove heavy grease coatings with ethyl alcohol.

6 WEAR ITEMS & MAINTENANCE (CONT.)

6.2A SPU 2040 Drive AF

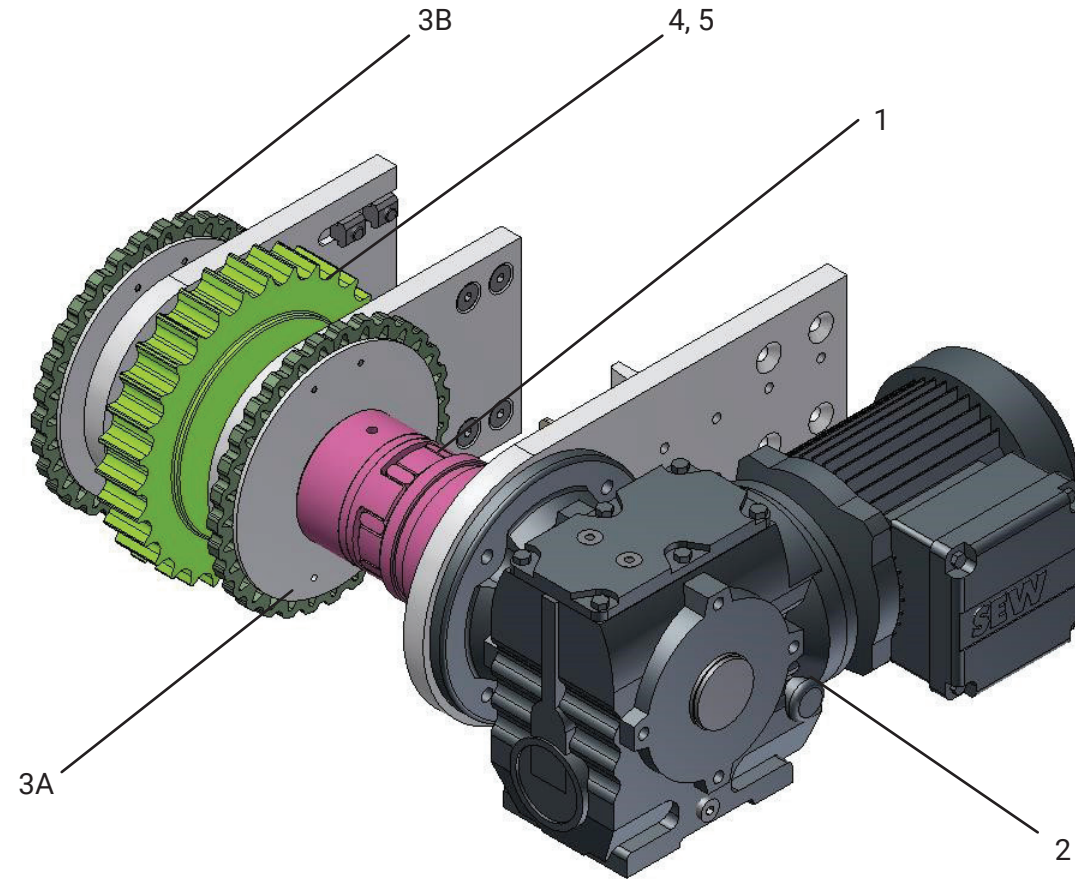

NOTE: Not all items shown in all views for clarity.

(Cont.)

6 WEAR ITEMS & MAINTENANCE (CONT.)

6.2A SPU 2040 Drive AF (Cont.)

Maintenance Work for SPU 2040 Drive AF

Position	Description	Action*	Interval in Hours (Months)
1	Coupling	I, C	1,000 Hours (Max. 6 Months)
		R	If wear is visible
2	Motor	I, C	500 Hours (Max. 3 Months)
			Maintenance according to manufacturer's instructions
3	Compression Disc	I, C <sup>1</sup>	500 Hours (Max. 3 Months)
		R	If wear is visible
4	Drive Sprocket	I, C	500 Hours (Max. 3 Months)
		R	If wear is visible
5	Drive Bearing	I	1,000 Hours (Max. 6 Months)
		R	If wear is visible

\* LEGEND: Inspect, Replace, Tension, Clean, Lubricate.

C<sup>1</sup> Do not use harsh chemicals when cleaning the Clutch Disc.

C<sup>1</sup> ABSOLUTELY NO OILS OR LUBRICANTS MAY COME IN CONTACT with Clutch Disc

Wear Items for SPU 2040 Drive AF

Position	Description	Part Number
1	Coupling	Inquire with mk North America
2	Motor	Inquire with mk North America
3A	Compression Disc (Motor)	58.00.0029
3B	Compression Disc	58.00.0028
4	Drive Sprocket	K114511013
5	Drive Bearing	K101000413

6 WEAR ITEMS & MAINTENANCE (CONT.)

6.2B SPU 2040 Drive AC

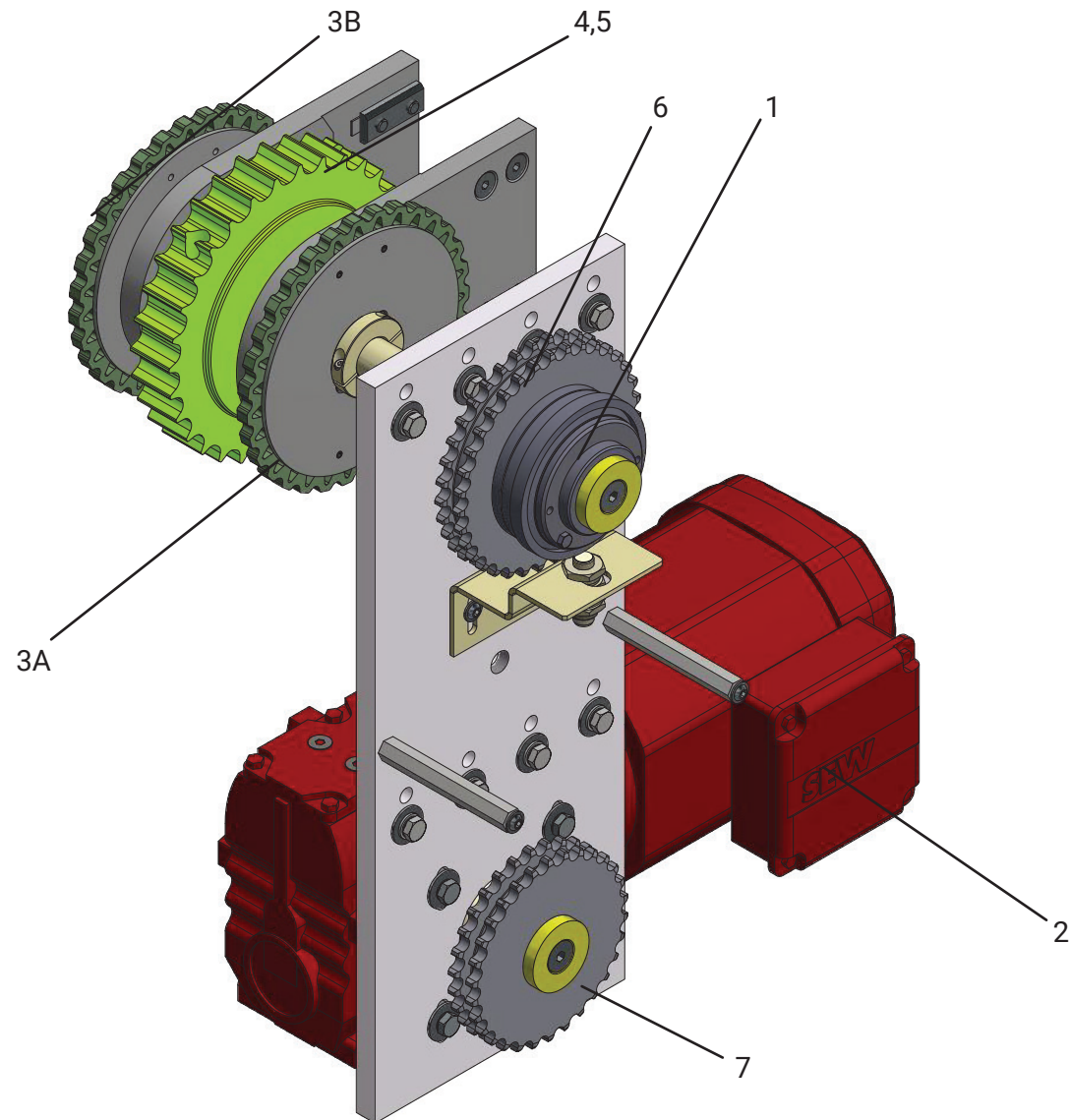

Position	Description	Action*	Interval in Hours (Months)	Lubricant
1	Overload Clutch	I, C	1,000 Hours (Max. 6 Months)	
		R	If wear is visible	
2	Motor	I, C	500 Hours (Max. 3 Months)	
			Maintenance according to manufacturer's instructions	

NOTE: Not all items shown in all views for clarity.

(Cont.)

6 WEAR ITEMS & MAINTENANCE (CONT.)

6.2B SPU 2040 Drive AC (Cont.)

Maintenance Work for SPU 2040 Drive AC

Position	Description	Action*	Interval in Hours (Months)	Lubricant
3	Compression Disc	I, C <sup>1</sup>	500 Hours (Max. 3 Months)	
		R	If wear is visible	
4	Drive Sprocket	I, C	500 Hours (Max. 3 Months)	
		R	If wear is visible	
5	Drive Bearing	I	1,000 Hours (Max. 6 Months)	
		R	If wear is visible	
6	Drive Train Sprocket, Conveyor	I, C	1,000 Hours (Max. 6 Months)	
		R	If wear is visible	
7	Drive Train Sprocket, Motor	I, C	1,000 Hours (Max. 6 Months)	
		R	If wear is visible	
8	Drive Train Chain (not shown)	I, C, T, L	1,000 Hours (Max. 6 Months)	SAE20-SAE50
		R	If wear is visible	

\* LEGEND: Inspect, Replace, Tension, Clean, Lubricate.

C<sup>1</sup> Do not use harsh chemicals when cleaning the Clutch Disc.

C<sup>1</sup> ABSOLUTELY NO OILS OR LUBRICANTS MAY COME IN CONTACT with Clutch Disc

Wear Items for SPU 2040 Drive AC

Position	Description	Part Number
1	Sprocket w/ Overload Clutch	Inquire with mk North America
2	Motor	Inquire with mk North America
3A	Compression Disc (Motor)	58.00.0029
3B	Compression Disc	58.00.0028
4	Drive Sprocket	K114511013
5	Drive Bearing	K101000413
6	Drive Train Sprocket, Motor	Inquire with mk North America
7	Drive Train Sprocket, Conveyor	Inquire with mk North America
8	Drive Train Chain	Inquire with mk North America



6 WEAR ITEMS & MAINTENANCE (CONT.)

6.3 SPU 2040 Idler, with Pneumatic Tensioning Device

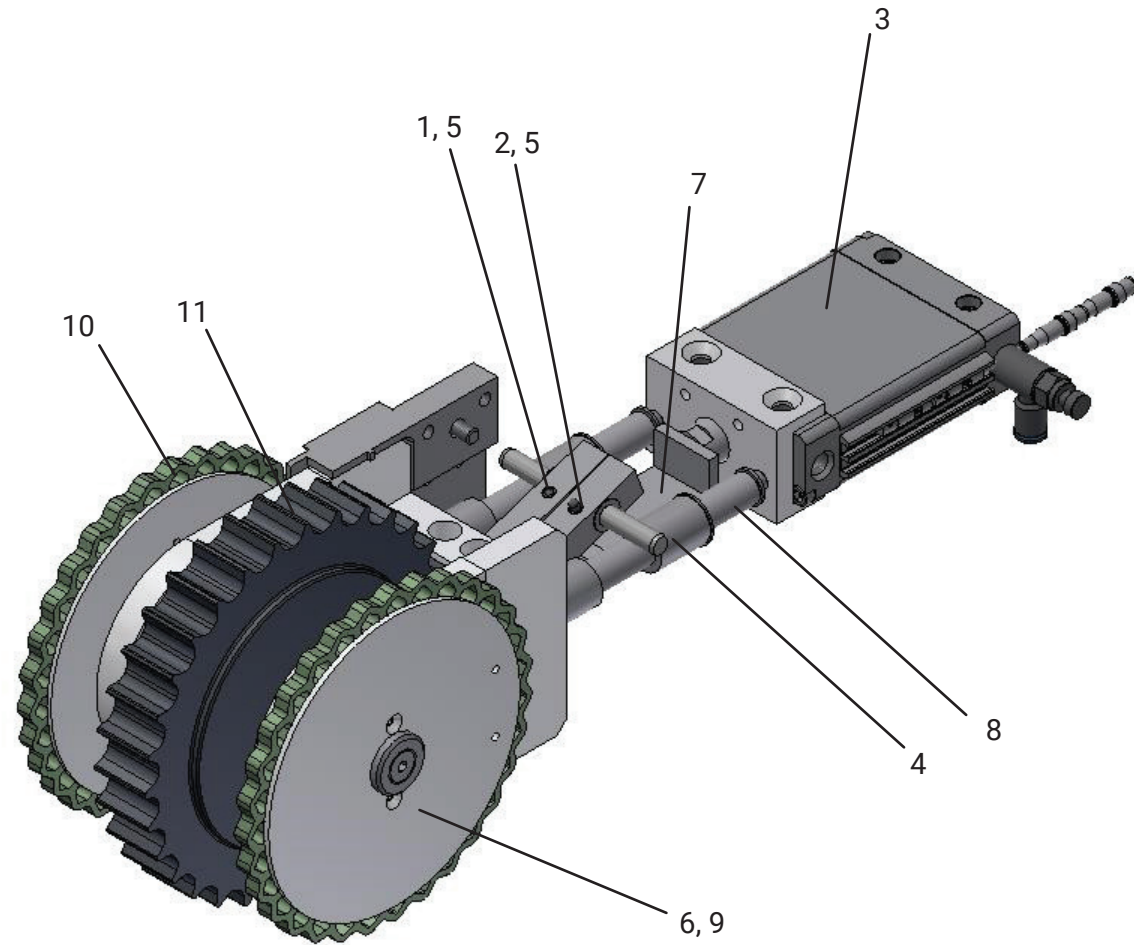

NOTE: Not all items shown in all views for clarity.

(Cont.)

6 WEAR ITEMS & MAINTENANCE (CONT.)

6.3 SPU 2040 Idler, with Pneumatic Tensioning Device (Cont.)

Maintenance Work for SPU 2040 Idler, with Pneumatic Tensioning Device

Position	Description	Action*	Interval in Hours (Months)
1	Pawl Long	I, C	500 Hours (Max. 3 Months)
		R	If wear is visible
2	Pawl Short	I, C	500 Hours (Max. 3 Months)
		R	If wear is visible
3	Flat Cylinder	I, C	500 Hours (Max. 3 Months)
		R	If wear is visible Maintenance according to manufacturer's instructions
4	Linear Ball Bearing	I, C	500 Hours (Max. 3 Months)
		R	If chain stretch is greater than 3%
5	Spring Plunger	I, C	500 Hours (Max. 3 Months)
		R	If wear is visible
7	Index Rack	I, C	500 Hours (Max. 3 Months)
		R	If wear is visible
8	Guide Rod	I, C	500 Hours (Max. 3 Months)
		R	If wear is visible
9	Roller Bearing	I, C	1,000 Hours (Max. 6 Months)
		R	If wear is visible
10	Compression Disc	I, C <sup>1</sup>	500 Hours (Max. 3 Months)
		R	If wear is visible
11	Sprocket	I, C	500 Hours (Max. 3 Months)
		R	If wear is visible

\* LEGEND: Inspect, Replace, Tension, Clean, Lubricate.

C<sup>1</sup> Do not use harsh chemicals when cleaning the Clutch Disc.

C<sup>1</sup> ABSOLUTELY NO OILS OR LUBRICANTS MAY COME IN CONTACT with Clutch Disc

NOTE: For adjusting the chain tensioning, please see the related section for details. When cleaning the chain, avoid any harsh chemicals or detergents.

6 WEAR ITEMS & MAINTENANCE (CONT.)

6.3 SPU 2040 Idler, with Pneumatic Tensioning Device (Cont.)

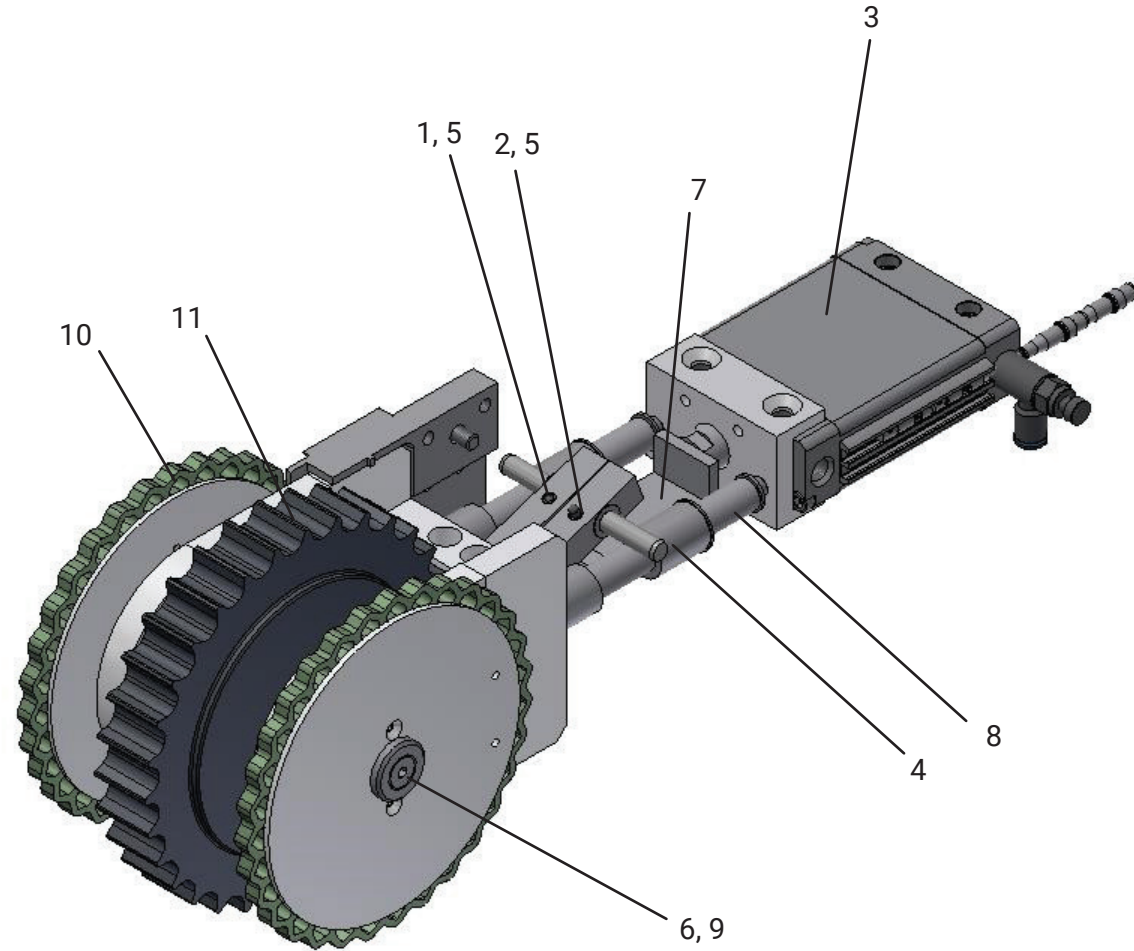

NOTE: Not all items shown in all views for clarity.

(Cont.)

6 WEAR ITEMS & MAINTENANCE (CONT.)

6.3 SPU 2040 Idler, with Pneumatic Tensioning Device (Cont.)

Wear Items for SPU 2040 Idler

Position	Description	Part Number
1	Pawl, Long	67.01.0002
2	Pawl, Short	67.04.0001
3	Flat Cylinder	P85.01.002
4	Linear Ball Bearing	K101130065
5	Spring Plunger	K119010002
6	Tail Shaft	Inquire with mk North America
7	Index Rack	67.01.0003
8	Guide Rod	7003CX0175
9	Roller Bearing	K101000413
10	Compression Disc	58.00.0028
11	Sprocket	K114511013

NOTE: For adjusting the chain tensioning, please see the related section for details. When cleaning the chain, avoid any harsh chemicals or detergents.

6 WEAR ITEMS & MAINTENANCE (CONT.)

6.4 SPU 2040 Locating Device

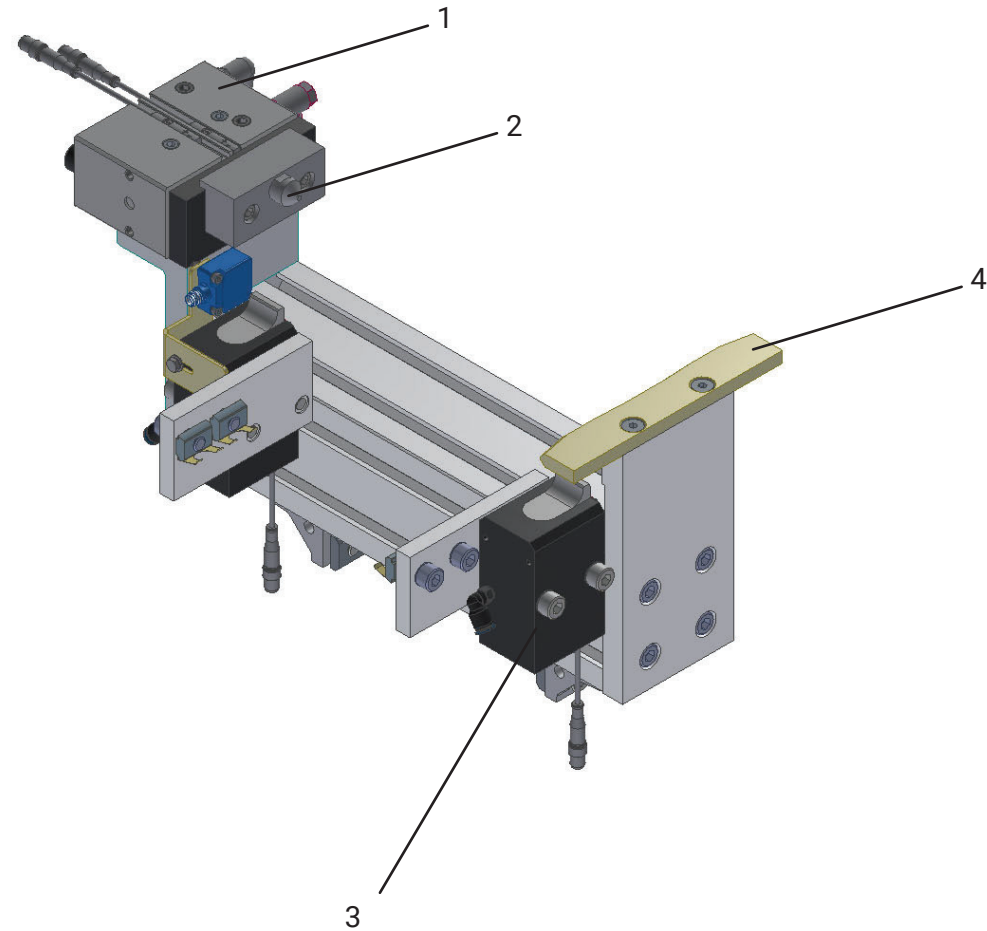

NOTE: Not all items shown in all views for clarity.

(Cont.)

6 WEAR ITEMS & MAINTENANCE (CONT.)

6.4 SPU 2040 Locating Device (Cont.)

Maintenance Work for SPU 2040 Locating Device

Position	Description	Action*	Interval in Hours (Months)
1	Cylinder	R	If wear is visible
2	Centering Bolt	R	If wear is visible
3	Stop Cylinder	R	If wear is visible
4	Backstop (Prism)	R	If wear is visible

\* LEGEND: Inspect, Replace, Tension, Clean, Lubricate.

Wear Items for SPU 2040 Locating Device

Position	Description	Part Number
1	Cylinder	Inquire with mk North America
2	Centering Bolt	05.05.0007
3	Stop Cylinder	K503011401
4	Backstop	03.01.0012

6 WEAR ITEMS & MAINTENANCE (CONT.)

6.5 SPU 2040 Pallet Singulator (Top or Return Mount)

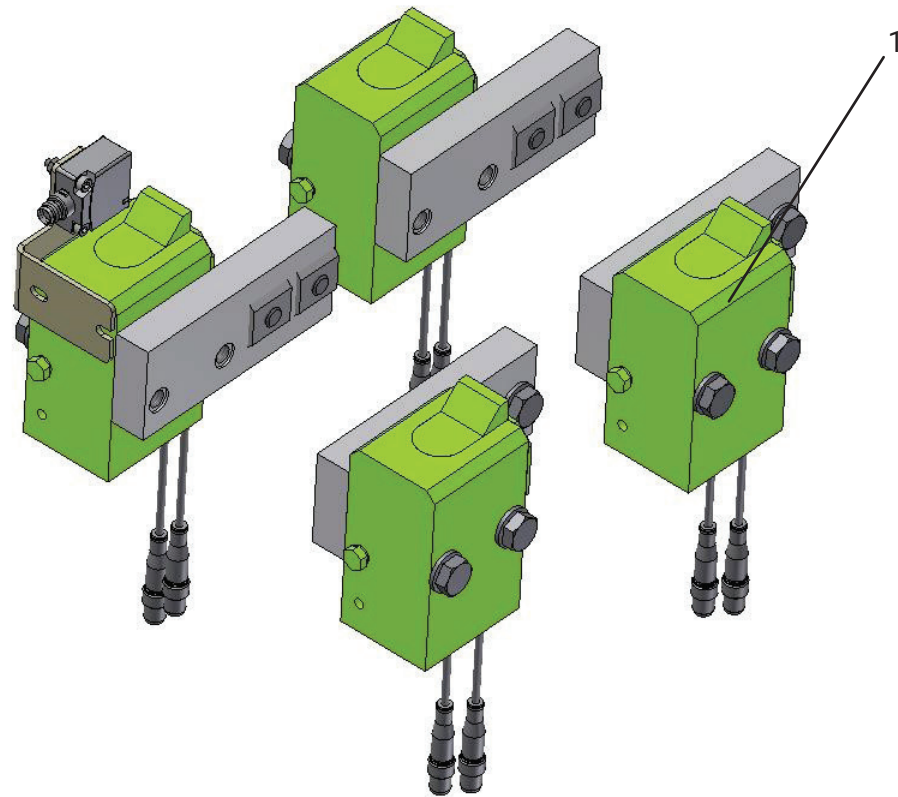

NOTE: Not all items shown in all views for clarity.

(Cont.)

6 WEAR ITEMS & MAINTENANCE (CONT.)

6.5 SPU 2040 Pallet Singulator (Top or Bottom Mount) (Cont.)

Maintenance Work for SPU 2040 Separator

Position	Description	Action*	Interval in Hours (Months)
1	Cylinder	R	If wear is visible

\*LEGEND: Inspect, Replace, Tension, Clean, Lubricate.

Wear Items for SPU 2040 Pallet Singulator

Position	Description	Part Number
1	Cylinder - Top Mount	K503011401
1	Cylinder - Return Mount (Not shown)	K503011406

6 WEAR ITEMS & MAINTENANCE (CONT.)

6.6 SPU 2040 Stop

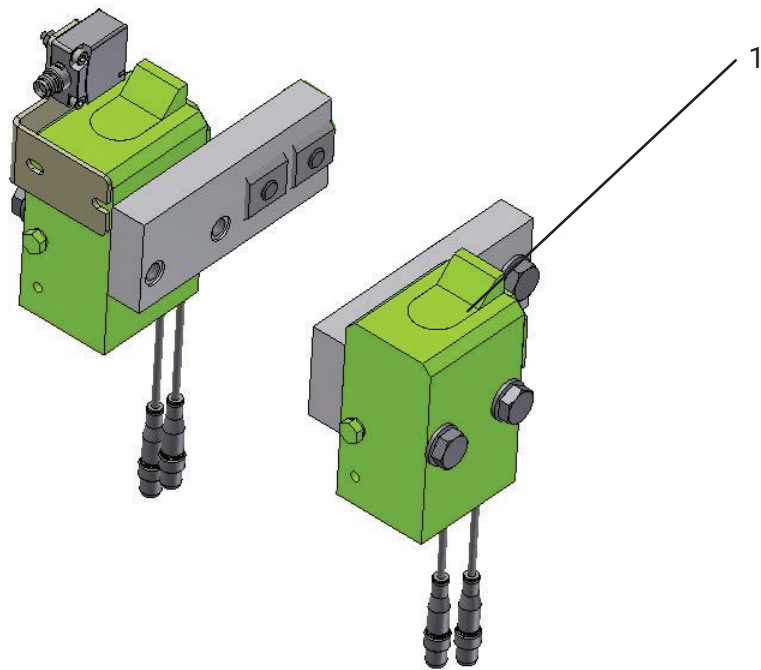

NOTE: Not all items shown in all views for clarity.

(Cont.)

6 WEAR ITEMS & MAINTENANCE (CONT.)

6.6 SPU 2040 Stop (Cont.)

Maintenance Work for SPU 2040 Stop

Position	Description	Action*	Interval in Hours (Months)
1	Cylinder	R	If wear is visible

\* LEGEND: Inspect, Replace, Tension, Clean, Lubricate.

Wear Items for SPU 2040 Stop

Position	Description	Part Number
1	Cylinder - Top Mount	K503011401
1	Cylinder - Return Mount (Not shown)	K503011406

6 WEAR ITEMS & MAINTENANCE (CONT.)

6.7 SPU 2040 Pallet

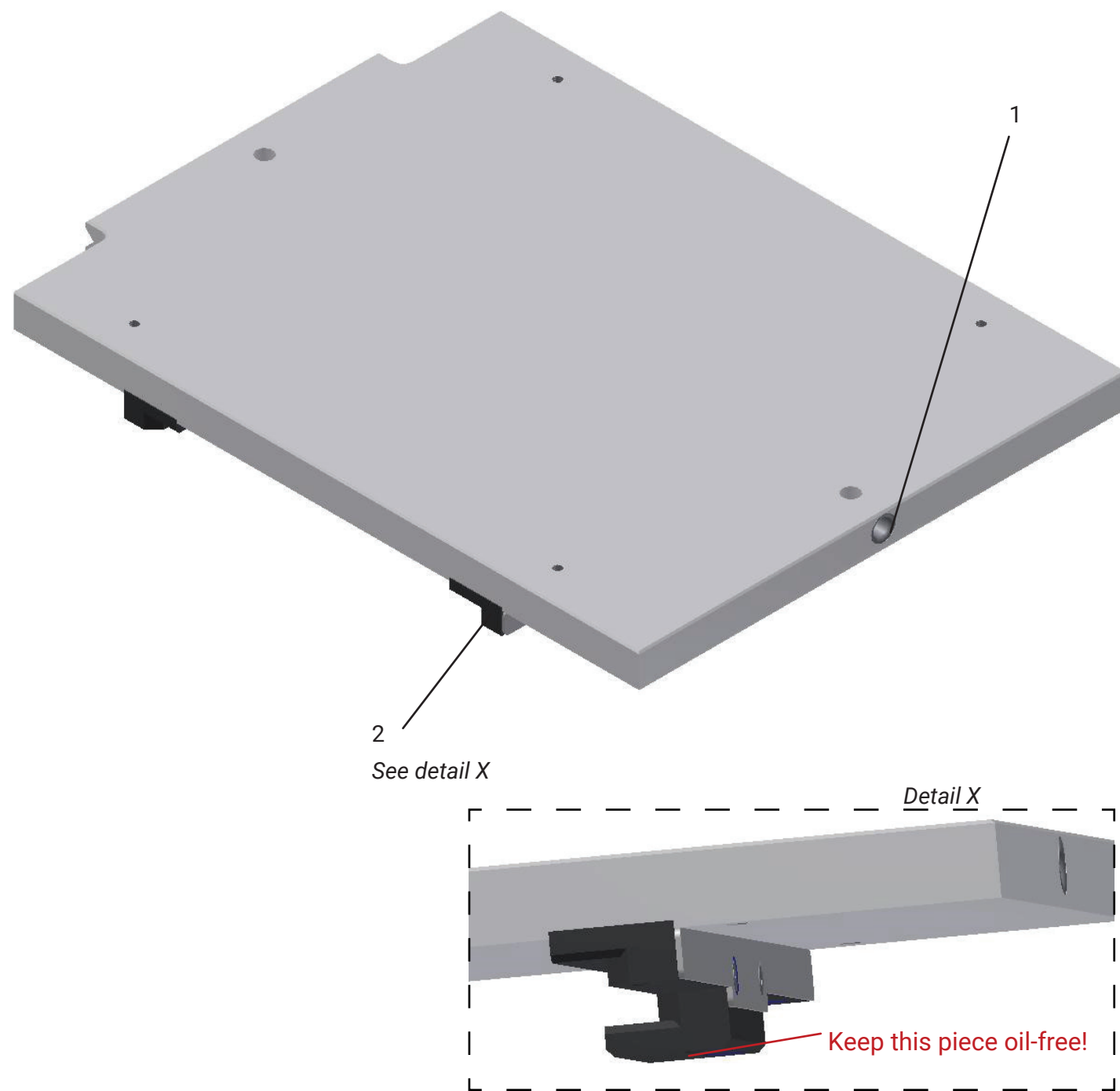

NOTE: Not all items shown in all views for clarity.

(Cont.)

6 WEAR ITEMS & MAINTENANCE (CONT.)

6.7 SPU 2040 Pallet (Cont.)

Maintenance Work for SPU 2040 Pallet

Position	Description	Action*	Interval in Hours (Months)
1	Bushing	I, C	500 Hours (Max. 3 Months)
		R	If wear is visible
2	Wear Strip	I, C	500 Hours (Max. 3 Months)
		R	If wear is visible

\* LEGEND: *Inspect, Replace, Tension, Clean, Lubricate.*

Wear Items for SPU 2040 Pallet

Position	Description	Part Number
1	Bushing	D01791012
2	Wear Strip	Inquire with mk North America

6 WEAR ITEMS & MAINTENANCE (CONT.)

6.8 SPU 2040 Frame and Chain

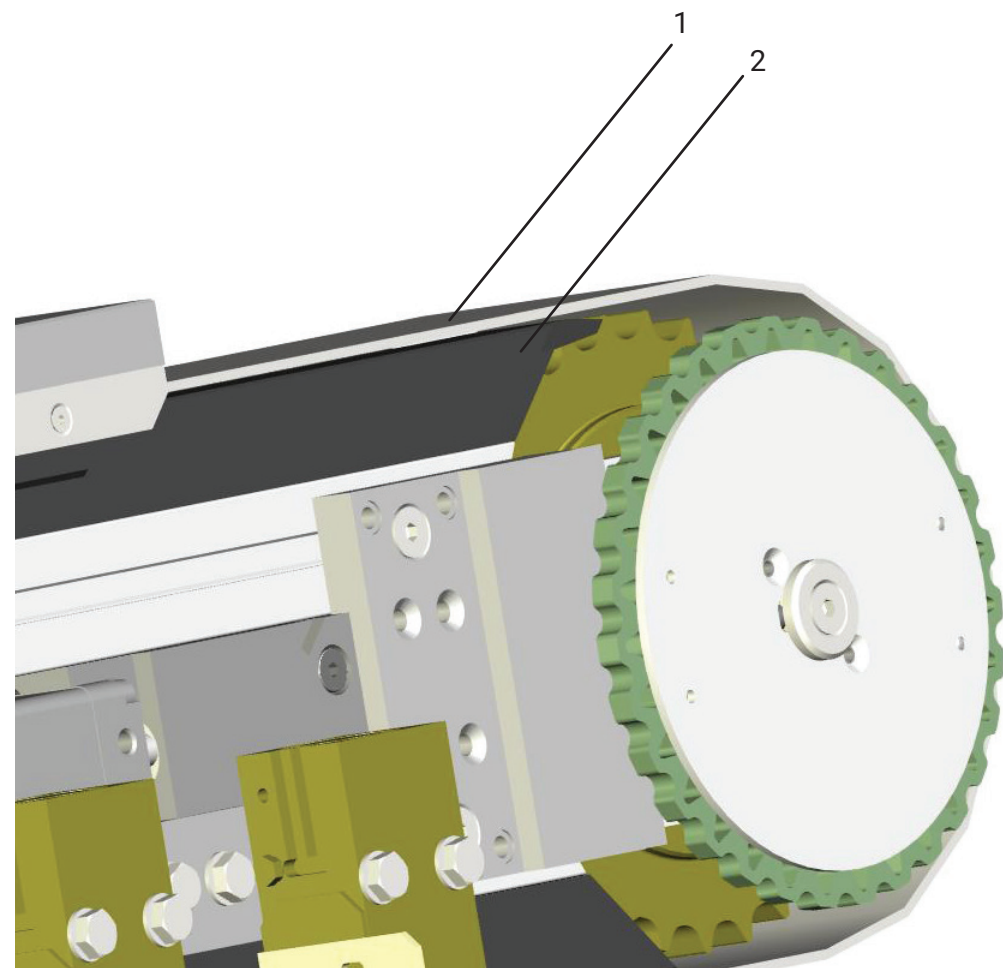

6 WEAR ITEMS & MAINTENANCE (CONT.)

6.8 SPU 2040 Frame and Chain (Cont.)

Maintenance Work for SPU 2040 Frame and Chain

Position	Description	Action*	Interval in Hours (Other)	Lubricant
1	Chain	I	24 Hours (Daily)	Hinge Lubricant P95.10.002
		L	400 Hours	
2	Wear Strip	I, C	500 Hours (Max. 3 Months)	
		R	If wear is visible	

\* LEGEND: *Inspect, Replace, Tension, Clean, Lubricate.*

Wear Items for SPU 2040 Frame and Chain

Position	Description	Part Number
1	Chain	Inquire with mk North America
2	Wear Strip	Inquire with mk North America

6 WEAR ITEMS & MAINTENANCE (CONT.)

6.9 SPU 2040 Cover

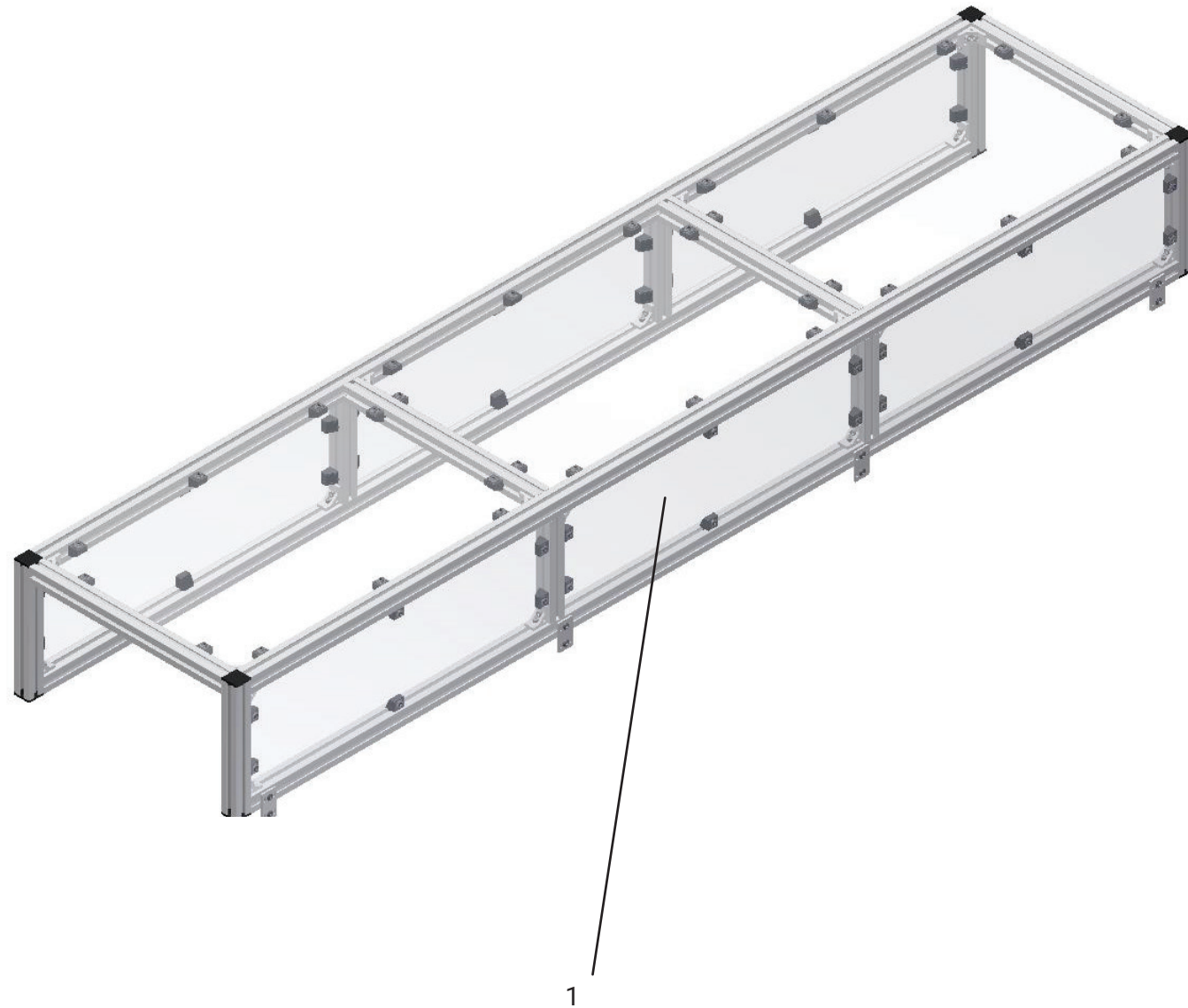

6 WEAR ITEMS & MAINTENANCE (CONT.)

6.9 SPU 2040 Cover (Cont.)

Maintenance Work for SPU 2040 Cover

Position	Description	Action*	Interval in Hours (Months)
1	Paneling	I, C <sup>1</sup>	1,000 Hours (Max. 6 Months)
		R	If wear is visible

\* LEGEND: *Inspect, Replace, Tension, Clean, Lubricate.*

C<sup>1</sup> Do **not** use harsh chemicals when cleaning the polycarbonate panels.



## 7 CONVEYOR CHAIN MAINTENANCE - TENSIONING & TRACKING

7.1	Tensioning	29
7.2	Removing Chain Links	30



All work to be performed by qualified personnel only.

Use extreme caution of all pinch, pull and other hazards.

### Attention:

Tensioning of the flat top chain must be performed with the conveyor in operation - USE EXTREME CAUTION - RISK OF INJURY.

During the run-in period (but **before the first 300 hours** of operation is exceeded), the flat top chain **must be checked daily** for the following:

- No oscillation in the flat top chain
- No unusually loud noises
- The maximum elongation in the flat top chain may not exceed 4 percent.
- A thin lubrication film must be present (not sprayed) on the contact surfaces between wear strips and at the joints of the flat top chain.
- The clutch discs on the drive and the tail / tensioning device must remain free of oil.

## 7 CONVEYOR CHAIN MAINTENANCE - TENSIONING & TRACKING (CONT.)

### 7.1 Tensioning



All work to be performed by qualified personnel only.

**Before beginning work, disconnect, and lock-out power to the conveyor.**

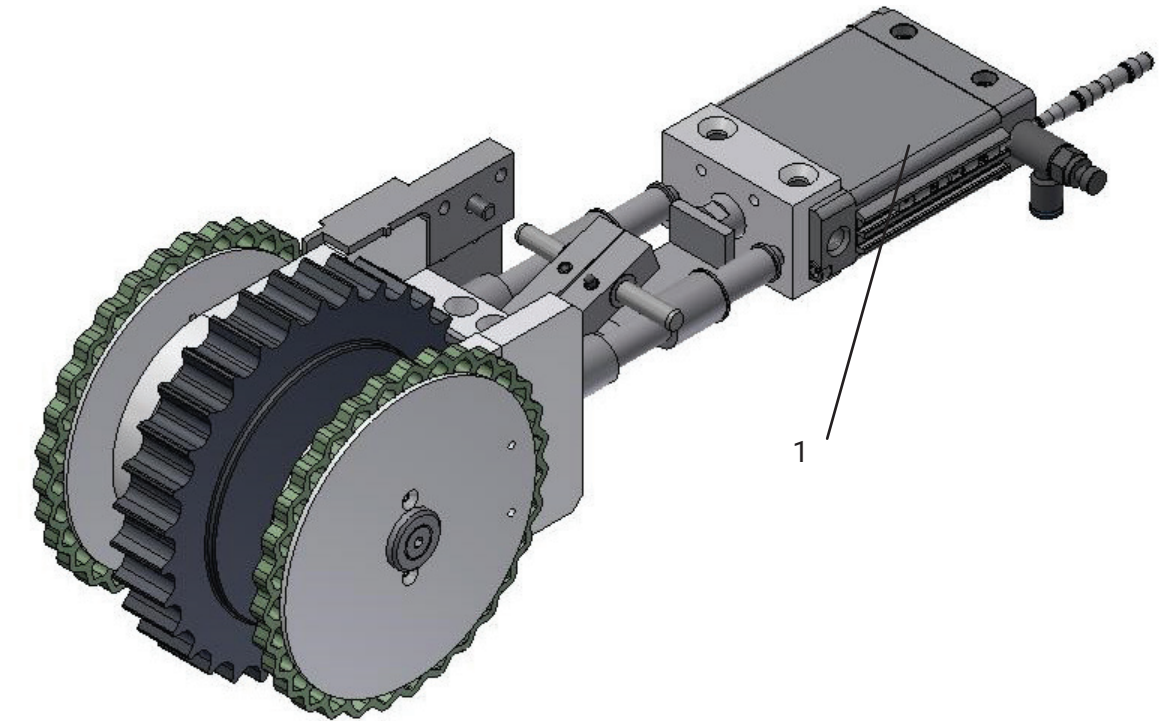

### Note:

The cylinder (1) must remain activated at a constant pressure of 6 bar in order to guarantee sufficient pre-tension in the chain.

A pawl prevents the tail from slipping backward if the compressor or the compressed air supply fails. The maximum tensioning travel is 20 to 25 mm. Once this has been reached, a signal is transmitted to the controller via a reed contact. Subsequently the chain must be shortened by one link within 40 or no more than 80 hours.

### Note:

When tensioning the flat top chain, ensure that it is not oscillating or producing unusually loud noises. It must be guaranteed that the pallets move smoothly up and down around the bend. Skipping in the chain should be avoided.

## 7 CONVEYOR CHAIN MAINTENANCE - TENSIONING & TRACKING (CONT.)

### 7.2 Removing Chain Links



All work to be performed by qualified personnel only.

**Before beginning work, disconnect, and lock-out power to the conveyor.**

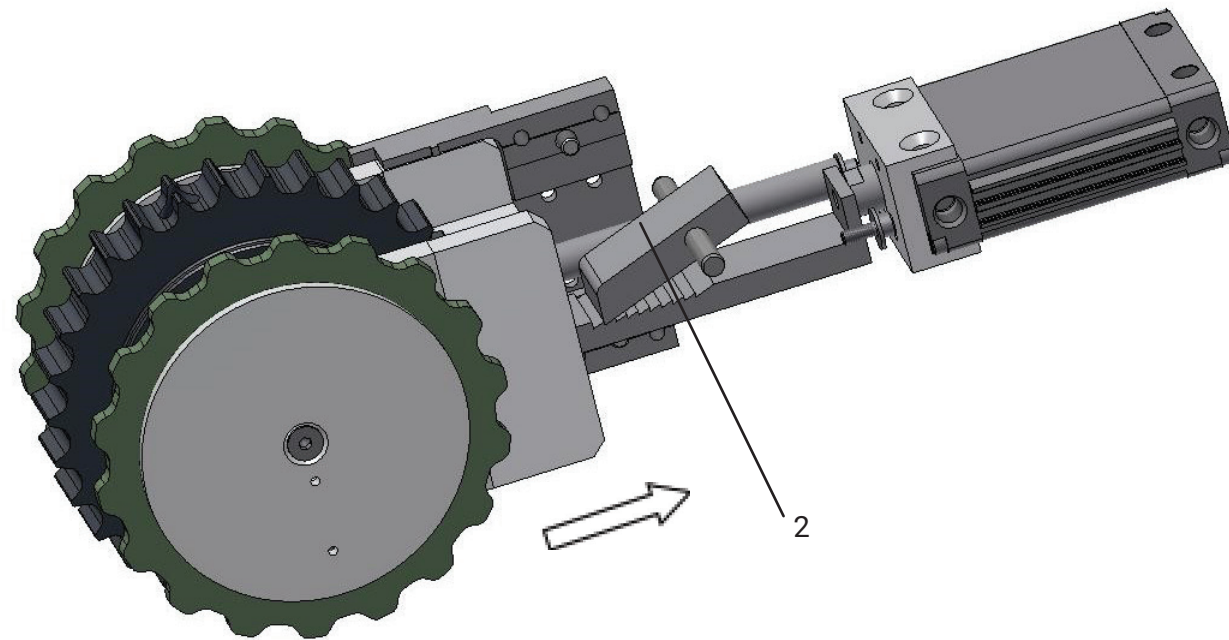

To remove a chain link, use a suitable tool (such as a long #4 Allen key) to drive a cotter pin out of the flat top chain and release a chain link. Lift the pawl (2) using a suitable tool (such as a screwdriver, or long Allen wrench) and push the tensioning unit back in the direction of the arrow. Reconnect the ends of the flat top chain by driving the cotter pin back in.

Once the flat top chain has been shortened by 4 to 6 chain links, but no later than once the chain has lengthened by 4%, we recommend replacing the entire flat top chain as well as the chain wheels.

After the flat top chain has been installed, the tensioning unit is to be put under constant pressure of 6 bar.

## 8 NOTES & CONTACT INFORMATION



[sales@mknorthamerica.com](mailto:sales@mknorthamerica.com)

[spareparts@mknorthamerica.com](mailto:spareparts@mknorthamerica.com)

[service@mknorthamerica.com](mailto:service@mknorthamerica.com)



(860) 769-5500

Technical Documentation  
SPU 2040  
Accumulating Roller Chain Conveyor

**mk North America, Inc.**  
an mk Technology Group Company  
105 Highland Park Drive  
Bloomfield, CT 06002, USA  
Phone: (860) 769-5500

[www.mknorthamerica.com](http://www.mknorthamerica.com)  
[sales@mknorthamerica.com](mailto:sales@mknorthamerica.com)

All rights reserved, information subject to change without notice. © 2024 mk North America, Inc.

REV. 2024.03.11